

# NEX FLOW™

AIR PRODUCTS CORP.

The New leaders in Specialized Compressed Air Technology -  
Over 20 years experience and knowledge.  
TRULY GLOBAL COMPANY for this technology



Panel Coolers

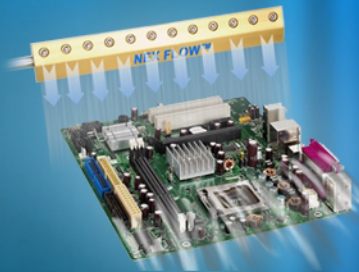

Air Knives

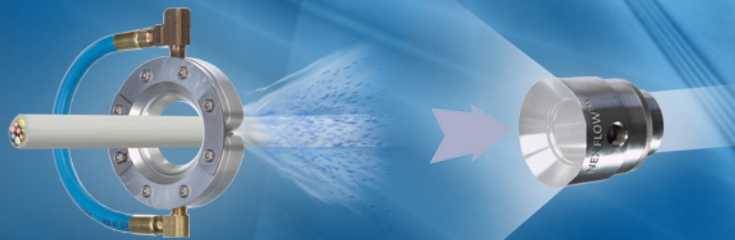

Air Wipes

Air Amplifiers

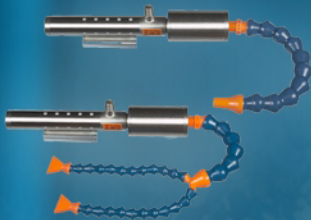

Tool coolers



Air Nozzles and  
Jets



Safety Air Blowoff  
Guns



Static Eliminators



Vortex Tubes and  
Spot Cooling

Air Operated  
Conveyors



Housekeeping &  
Specialty Products



Air Optimization  
Products

**SMART N CLEVER™**  
MORE THAN INTELLIGENT

January 2016

**Air Products to Improve Productivity and Optimize Energy Use**

# NEX FLOW™

## AIR PRODUCTS CORP.

**TO ALL OF OUR CUSTOMERS AND SALES AGENTS AROUND THE WORLD** Thank you for your continued support in our mission to improve plant productivity, reduce overall costs in production in the areas of energy and maintenance and to enhance the environment.

We promise to continue our research and development to improve our existing products, add new products and to educate the market place in this still growing technology. As the “new” leaders in specialized compressed air technology we recognize the key to maintaining this leadership is to actually lead with the best products and the best education with integrity so the customer can make knowledgeable choices.

### **Nex Flow™ offers:**

- 1. Great Support :** To assist you in the use of the technology, demonstration units if required for test on valid applications.
- 2. Special Products :** Custom designs, special materials as you may need for your specific environment. If you have an idea, we will work with you.
- 3. Fast Delivery :** Stock items for quick delivery on most items.
- 4. Guarantee :** Nex Flow™ warrants its products against defects in material and workmanship for five years from the date of purchase of main pneumatic items (amplification products, venturi products, vortex tube products), two years for static control power supplies, one year on other electrical items and one year on accessories such as filters and regulators.

**We look forward to serving your needs and to assure you are satisfied with the service from Nex Flow™ and their partners and associates around the world.**

### **Contact us direct or our local partners around the world:**

USA and CANADA call toll free +1-877-797-2777 INTERNATIONAL call +1-416-410-1313 Fax +1-416-410-1806

**Email:** sales@nexflow.com or sales@nexflowair.com or sales@nex-flow.com

**Web:** www.nexflow.com www.nexflowair.com www.nex-flow.com

## INDEX

**Smart N Clever™ Air Products to improve productivity and optimize energy use**  
**Engineered Compressed Air Technology for blowoff, cooling, cleaning, conveying, static control and specialty industrial and housekeeping applications.**

Section A	<p><b>SMART N CLEVER™ OPTIMIZATION PRODUCTS</b></p> <p>To minimize the use of compressed air and monitor leaks, noise and flow</p>		Section B	<p><b>AIR BLADE™ AIR KNIVES</b></p> <p>For blowoff, cleaning and cooling with reduced air and noise levels</p>	
Section C	<p><b>RING BLADE™ AIR WIPE SYSTEM</b></p> <p>For blowoff and cooling of cable, hose, pipe and all types of extruded shapes</p>		Section D	<p><b>AIR AMPLIFIERS</b></p> <p>For blowoff, cooling, drying and venting with reduced air and noise levels</p>	
Section E	<p><b>AIR NOZZLES AND JETS</b></p> <p>For reducing energy costs and noise in blowoff applications</p>		Section F	<p><b>SMART N CLEVER™ AIR GUNS</b></p> <p>With high performance Air Nozzles for energy saving</p>	
Section G	<p><b>STATIC ELIMINATORS</b></p> <p>To remove static charge and for dirt control on plastics and other charged surfaces</p>		Section H	<p><b>RING VAC™ AIR OPERATED CONVEYOR SYSTEMS</b></p> <p>To convey solid materials, parts, etc. with no moving parts</p>	
Section I	<p><b>SPECIALTY SMART N CLEVER™ PRODUCTS</b></p> <p>For housekeeping, liquid transfer, cleaning, conveying and cooling</p>		Section J	<p><b>FRIGID-X™ VORTEX TUBES AND SPOT COOLING</b></p> <p>Cold air devices with no moving parts for spot cooling</p>	
Section K	<p><b>FRIGID-X™ TOOL COOLERS</b></p> <p>For dry machining operations to improve quality and speed</p>		Section L	<p><b>FRIGID-X™ PANEL COOLERS</b></p> <p>Maintenance free electrical and electronic enclosure cooling, ULC approved, CE Compliant</p>	
Section M	<p><b>ACCESSORIES</b></p> <p>Mufflers, Filters, Mounting Systems and Specialty Products</p>		Addendum	<p><b>ADDENDUM I</b> Air Amplification Explained and How it is Measured</p> <p><b>ADDENDUM II</b> Vortex Tube Explained &amp; Performance Measurement</p>	

### The New Leaders in Specialized Compressed Air Technology

Nex Flow™ Air Products Corp. 300 International Drive, Unit 100, Williamsville, NY, USA, 14221

Nex Flow™ Air Products Corp. 10520 Yonge ST., Unit 35B-220, Richmond Hill, ON, Canada, L4C 3C7

Phone:- +1-416-410-1313 Fax:- +1-416-410-1806

E-mail:- sales@nexflow.com ▪ sales@nexflowair.com ▪ sales@nex-flow.com

Web:- www.nexflow.com ▪ www.nexflowair.com ▪ www.nex-flow.com

## Terms and Conditions

for the USA and Canada (may vary in other countries)

### TERMS :

Net 30 days subject to credit approval. Visa, MasterCard and American Express accepted. All taxes extra as applicable (not included).



### FOB :

Nex Flow™ Air Products Corp. factory warehouse, Mississauga (Toronto area), Ontario, Canada. For UPS shipments freight is normally prepaid and added to the invoice or customer account utilized.

### DELIVERY :

Most cataloged items shipped from stock within 24 hours from receipt of order. Priority shipments can be arranged on request.

### ORDERING :

In the USA and CANADA call toll free +1-877-797-2777 and dial extension 1. Outside of the USA and CANADA call your local agent, or call +1-416-410-1313 and dial extension 1. Operating hours are 9:00 am to 5:00 pm Eastern Time Monday to Friday except holidays

To Fax, within the USA and CANADA Fax toll free +1-877-797-2777. Outside USA and CANADA Fax +1-416-410-1806

Email : ▪ [orders@nexflow.com](mailto:orders@nexflow.com) ▪ [orders@nexflowair.com](mailto:orders@nexflowair.com) ▪ [order@nex-flow.com](mailto:order@nex-flow.com)

Web Sites : ▪ [www.nexflow.com](http://www.nexflow.com) ▪ [www.nexflowair.com](http://www.nexflowair.com) ▪ [www.nex-flow.com](http://www.nex-flow.com)

### PAYMENTS TO :

Nex Flow™ Air products Corp., 10520 Yonge Street, Unit 35B-220, Richmond Hill, ON, Canada, L4C 3C7 **OR**

Nex Flow™ Air Products Corp., 300 International Drive, suite 100, Williamsville, NY, USA, 14043

### TECHNICAL SUPPORT :

In the USA and CANADA call toll free +1-877-797-2777 and dial extension 6. Outside of the USA and CANADA call your local agent, or call +1-416-410-1313 and dial extension 6. Or you may Email: [technical@nexflow.com](mailto:technical@nexflow.com), [technical@nexflowair.com](mailto:technical@nexflowair.com), [technical@nex-flow.com](mailto:technical@nex-flow.com)

### WARRANTY :

The Nex Flow™ 5 year warranty applies against defects in workmanship and materials on all compressed air blowoff, conveying and cooling products, 2 years on static control power supplies and 1 year on all other electrical items and accessories.

### TRIAL GUARANTEE :

Nex Flow™ offers trials on approved applications for up to 30 days and longer if necessary. We do not just send product to try with minimal support like some companies wasting your time on improper applications. We will actually assist you on your application and if a test is necessary we will send product on loan to test, returnable at no cost within 30 days or approved trial period (pay only the freight). We recognize your need for competent technical support and will advise you honestly on your application.

### COMPLIANCE :

Nex Flow™ compressed air blowoff, conveying and cooling products all comply with OSHA's Safety Requirements and those of the European Union and equivalent directives around the world. Electrical equipment complies with ROHS (Restriction of Hazardous Substances).

### COPYRIGHT :

The entire contents of this catalog is the sole property of Nex Flow™ Air Products Corp. and protected by International Copyright law. No part of this catalog may be reproduced for any commercial purposes without the prior consent in writing by Next Flow™ Air Products Corp.

### TRADEMARKS :

Nex Flow™ is a registered trademark of Nex Flow™ Air products Corp. as are other trademarks as noted in this catalog and others pending or obtained but may not yet be utilized. These trademarks may not be used without the prior consent in writing by Nex Flow™ Air Products Corp.

**Nex Flow™ Air Products Corp. 300 International Drive, Unit 100, Williamsville, NY, USA, 14221**

**Nex Flow™ Air Products Corp. 10520 Yonge ST., Unit 35B-220, Richmond Hill, ON, Canada, L4C 3C7**

**Phone:- +1-416-410-1313 Fax:- +1-416-410-1806**

**E-mail:-** ▪ [sales@nexflow.com](mailto:sales@nexflow.com) ▪ [sales@nexflowair.com](mailto:sales@nexflowair.com) ▪ [sales@nex-flow.com](mailto:sales@nex-flow.com)

**Web:-** ▪ [www.nexflow.com](http://www.nexflow.com) ▪ [www.nexflowair.com](http://www.nexflowair.com) ▪ [www.nex-flow.com](http://www.nex-flow.com)

## PLC FLOW CONTROL SYSTEM (PLCFC)

**Minimizes compressed air use for blowoff, cooling, cleaning, conveying, drying and static control applications to dramatically save on compressed air use.**

### WHAT IS IT - REASONS TO USE

The Nex Flow™ user-friendly PLC flow control system (PLCFC) for compressed air is truly advanced and uses the most modern technology available today and can be used as a stand alone unit or interfaced with other automated systems. The PLCFC is a PLC based system - not just a simple, sensor and timer. The PLCFC combines a photo electric sensor to turn on the air when the target passes the sensor and to turn off the air when it leaves the sensor. (The unit is set to have a 2 second delay after it leaves the sensor but turns on instantaneously when it sees the target). We can supply an optional timer if the customer wants to set the unit to turn off based on time rather than using the sensor to turn it off.

Some competitive units only offer a simple on-off with timer that does not really optimize the air use if the timer is set wrong and leaves the system running far longer than necessary. We can control not only solenoid valves for on-off but can control any electrical devices such as motors, fans, conveyor motors that carry the parts, etc. Also, our systems which come complete with one sensor, can operate with up to eight sensors (not just optical, but proximity switches and other kinds of sensing devices) for a multiple of independent tasks. Each task can be programmed. Nex Flow™ can offer the service of special programming according to customer needs.

In addition, you have a choice of any one of two types of sensors - a 500 mm sensing range diffuse type (no reflector needed) or a 3000 mm sensing range reflector type - all depending on the need. Other special sensors can be supplied on request such as laser sensors.

All this comes in a simple package at almost the same cost as the competition!

The system can be programmed to suit any special application the customer may have for blowoff systems, other automation applications or it can be tied into existing automated systems.

It is easily connected for either 110V or 220V making it suitable for worldwide use. The package is designed for all types of industrial environments including wash downs. This rugged unit is easy to install in tight places and is flexible and easy to use.

**A stainless steel Silent X-Stream™ Air Blade™ Air Knife is turned on and off automatically as the part to be dried passes under it.**

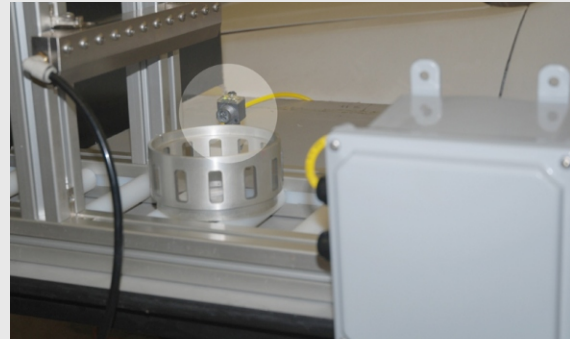

### ADVANTAGES:

- ▶ Easy to install and hook up - 110V to 220V
- ▶ Suitable for NEMA 4/IP56 environments
- ▶ Compact sensor for mounting in tight spaces
- ▶ Optional timer if desired - unit comes preset for tight on-off control for best results in saving air - a true optimizer
- ▶ Box has four mounting lugs for easy mounting
- ▶ Choice of sensors for use up to 3000 mm (10 feet)
- ▶ Sensors withstand water, dust, oil and coolant
- ▶ Sensors have superior immunity to noise and Inductive loads

**THE BEST CHOICE FOR OPTIMIZING YOUR OPERATION AND SAVING COMPRESSED AIR**



**Photoelectric sensor withstands dirt and water - two types of sensors are available, diffuse type or reflector type**



**PLCFC - HOW IT WORKS**

**PLC Flow Control Systems (PLCFC)** - The PLCFC combines a photo electric sensor to turn on the air when the target passes the sensor and to turn off the air when it leaves the sensor. (The unit is set to have a 2 second delay after it leaves the sensor but turns on instantaneously when it sees the target). In one example using an Air Knife, compressed air enters at point (A) into the Air Knife (B) only when the sensor (C) sees the target. The PLCFC is located at point (D). The target part (E) passes the sensor activating a solenoid to turn on the air flow to the Air Knife. The target travels on the conveyor (F). Two seconds after the target has passed the sensor, the air supply is turned off conserving energy. Different sensors are available for different applications and the units can be programmed for special applications.

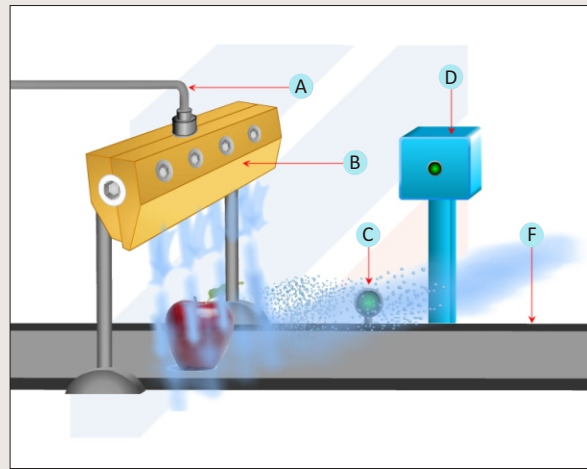

**APPLICATIONS :**

- ▶ Parts dust and debris blowoff
- ▶ Drying of parts
- ▶ Cleaning of parts before packaging
- ▶ Filing operations
- ▶ Cooling hot parts
- ▶ Static elimination & cleaning of plastic parts

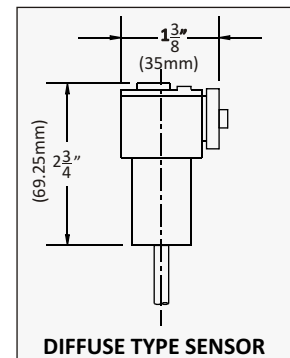
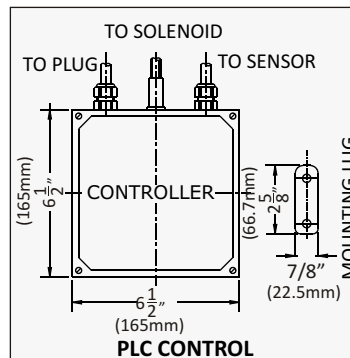

**PLC FLOW CONTROLLER SYSTEM**

PART NO.	DESCRIPTION
90055-40D	40 SCFM SYSTEM (includes one diffuse type sensor)
90055-40R	40 SCFM SYSTEM (includes one reflector type sensor)
90055-100D	100 SCFM SYSTEM (includes one diffuse type sensor)
90055-100R	100 SCFM SYSTEM (includes one reflector type sensor)
90055-200D	200 SCFM SYSTEM (includes one diffuse type sensor)
90055-200R	200 SCFM SYSTEM (includes one reflector type sensor)
90055-350D	350 SCFM SYSTEM (includes one diffuse type sensor)
90055-350R	350 SCFM SYSTEM (includes one reflector type sensor)

**PLCFC APPLICATION** - Compressed air use is reduced by 70% utilizing the PLCFC. Two Air Amplifiers used to cool castings only operate when the sensor “SEES” the castings and shuts them off two seconds after the castings are cooled. No timers need to be set.

Air Amplifiers cool the castings as they move along a conveyor. The sensor detects the part to turn on the amplifiers. The air turns off after 2 seconds after the castings have passed - an ideal “Plug and Play” solution to save compressed air.

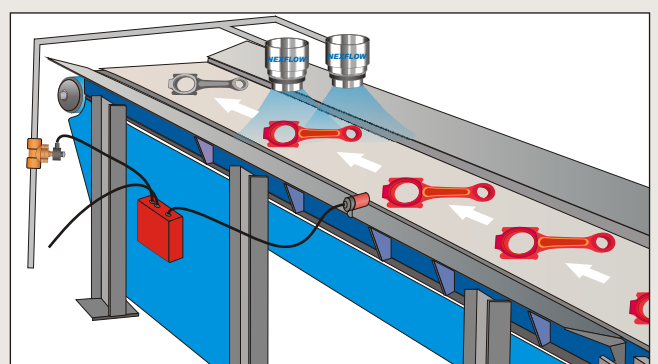

**SMART N CLEVER™ OPTIMIZATION PRODUCTS**

## ULTRASONIC LEAK DETECTOR

Locate costly compressed air leaks with optimum designed unit

### WHAT ARE THEY - REASONS TO USE

The Flex.US Ultrasonic Leak Detector is a hand held, high quality compressed air leak detection system that has all the features necessary for flexible use in finding costly air leaks.

The FLEX.US ultrasonic leak detector kit comes with the FLEX.US unit, carrying case, and manual and utilizes two AA alkaline batteries (included). The FLEX.US is a complete kit - the high quality flexible sensor is mounted on the end of a flexible steel pipe so the ultrasonic sound can access hard to reach areas. The unit converts the ultrasonic noise of a leak into a sound humans can hear (hissing sound) and not just some beeping sound or LED display that may not distinguish a leak sound from other phenomenon.

The headset has excellent noise attenuation for use in the noisiest of environments.

A rugged carrying case protects your FLEX.US when not in use.

The FLEX.US is a solid tool - built to last, it is easy to use and will provide many years of service.



Above shows use of quality headphones and flexible pipe with sensor to get to a difficult spot to find an air leak.



The Flex.US Ultrasonic Leak Detector has the sensor on the end of a flexible pipe to allow detection of leaks in difficult to reach areas.



The Ultrasonic Leak Detector comes in a handy carrying case to store the unit and quality headphones. The headphones are durable and of high quality to cut out extraneous noise that would make it difficult to detect leaks.



### HOW ULTRASOUND WORKS

Ultrasound is beyond human hearing capacity. Most humans hear frequencies from 2- Hz to 20 kHz. Ultrasonic sound is beyond this range at 20 kHz to 100 kHz. The FLEX.US unit converts the ultrasonic sound to an audible range to humans. Compressed air leaks generate this range of ultrasound “noise” that the unit picks up.

**WHY OUR ULTRASONIC LEAK DETECTOR DOES THE JOB AND WHY OTHERS MAY NOT**

**REMEMBER:**

The better the system, the more leaks you find and the more money you save! Always beware of cheap ultrasonic leak detectors that just may not do the job. Ours does the job because of the following:

**FIRST:**

Look at the headphones. If they are an open walkman style, these will be useless in a noisy plant because they offer absolutely NO protection from the ambient noise which can be at high levels! (After all, why else would you need an ultrasonic lead detector!) So how can you hear the leak in the headphone without protection from the ambient audible noise in the plant? Our headphones completely cover the ear providing 130 dBA hearing protection. Some competitive units would not be useable in a typical factory where hearing protection is mandatory because the inspector would have to insert ear plugs in his ears. Our headphones don't require this.

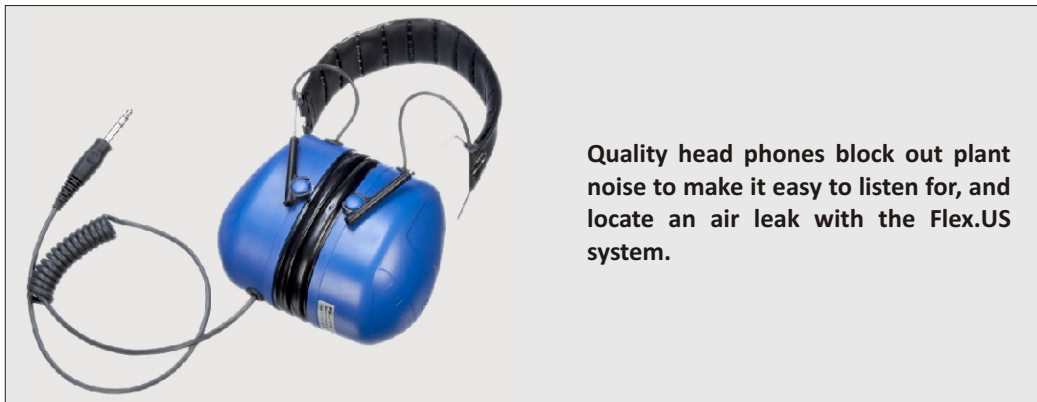

**Quality head phones block out plant noise to make it easy to listen for, and locate an air leak with the Flex.US system.**

**SECOND:**

Look at frequency range. Our frequency is centered at 38.4 kHz with an open window of +/- 2 kHz. By having a bandwidth this narrow we are able to eliminate other sources of ultrasonic parasite noise. It is absolutely critical that you amplify just this narrow single harmonic band of sound. Some detectors amplify every frequency from 20 kHz up to 100 kHz. That's because the manufacturer did not include any low pass filters. This also affects the output signal in the headphones. It also affects the directionality of the device. At low frequency it is much more difficult to know where the sound is coming from because the wavelength is larger and more reflective.

**THIRD:**

Extension tubes. For accessing tight areas some firms suggest using a hollow tube (tubular extension) with their system. Ultrasound will not travel well into this tube so the equipment will be less sensitive in hard to reach areas. If the tube is 6" long for example, that means the sensor is always a minimum of 6" away from the source. The Nex Flow™ system sensor is at the end of the flexible extension so the sensor is "always" directly exposed to the leak making our equipment much more sensitive. If more sensitive of course you will more easily detect the leak (one you may not even find with another system.)

**THE BETTER THE SYSTEM THE MORE LEAKS YOU FIND THE MORE YOU SAVE.**

**ULTRASONIC LEAK DETECTOR**

PART NO.	DESCRIPTION
90061	ULTRASONIC LEAK DETECTOR SYSTEM

**Nex Flow™ aims to be the lowest cost where possible but NOT at the expense of sacrificing quality.**



**X-STREAM™ FLOW METER**

Check air flow - monitor usage and waste!!!

**WHAT ARE THEY - REASONS TO USE**

**THE X-STREAM™ FLOW METER IS**

- ▶ Reliable, durable thermal mass flow technology
- ▶ Milliamp and pulse outputs for logging and remote monitoring
- ▶ 100:1 turndown capability
- ▶ Available for steel pipe, ½" through 2"
- ▶ No calibration or setup required
- ▶ Complete flow meter in one package



The X-Stream™ Flow Meter measures mass flow based on heat and on pipe diameter. Accurate flow rate tracks air consumption.



The X-STREAM™ FLOW METER represents a radical departure from conventional flow meter designs, providing easy installation, low cost, and accurate placement of the probes in the air stream. The meter clamps around a pipe with its probes projecting into the pipe through drilled holes. The low cost of the meter makes it ideal for installation at points throughout an air distribution system to track valuable compressed air and assess system operation.

**SPECIFICATIONS:**

- Accuracy** : 5 percent of reading plus one percent of full scale at air temperatures between 40°F and 120°F
  - Fluids** : Compressed air and nitrogen
  - Operating pressure** : 30 to 170 psig for best accuracy 200 psig maximum on Schedule 40 steel.
  - Input power** : 250 mA at 18 to 24 Vdc
  - Output resistance** : 400 Ohms max.
  - Wetted materials** : Stainless steel, gold, thermal epoxy and Viton (seal)
  - Ring material** : Aluminum
  - Display** : Four-digit LED display
  - Response time** : One second to 63 percent of final value
- US Patent 6,802,217**

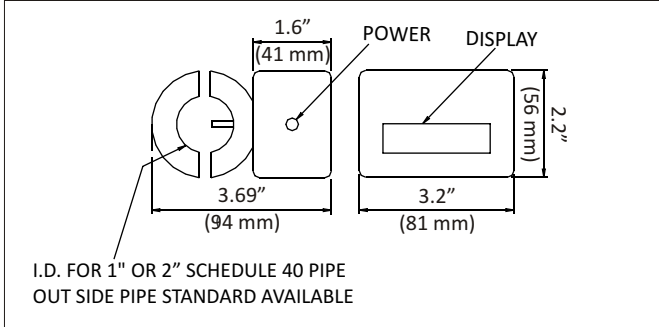

The X-Stream™ Flow Meter clamps onto a pipe, with two flow sensing probes projecting into the pipe through 3/16-in. drilled holes. It seals directly to the pipe; no cutting or welding is required for installation. Because each flow meter is made and calibrated for a specific size of pipe, the digital display indicates flow directly, with no setup or adjustment. The meter measures flow by maintaining one probe warmer than the other. It calculates the mass velocity from the amount of heat required, and then calculates the flow on the basis of pipe area. The flow rate, in SCFM, is shown on a large, four-digit display; a 4-20 mA output and a pulse output permit remote display, totalizing and data collection. Metric display is optional.

**ULTRASONIC LEAK DETECTOR**

PART NO.	DESCRIPTION
90092	1" (Schedule 40 iron pipe) 1 - 80 SCFM without Drill Guide Kit
90093	1.5" (Schedule 40 iron pipe) 2 - 200 SCFM without Drill Guide Kit
90095	2" (Schedule 40 iron pipe) 3 - 300 SCFM without Drill Guide Kit
DRG-9	Drill Guide Kit Only
90092-DRG-9	1" (Schedule 40 iron pipe) 1 - 80 SCFM with Drill Guide Kit
90093-DRG-9	1.5" (Schedule 40 iron pipe) 2 - 200 SCFM with Drill Guide Kit
90095-DRG-9	2" (Schedule 40 iron pipe) 3 - 300 SCFM with Drill Guide Kit

ABOVE FOR AMERICAN STANDARD STEEL PIPING - CAN ALSO SUPPLY TO DIN STANDARD OTHER PIPE SIZES & COPPER. QUOTE ON REQUEST



**X-STREAM™ SOUND LEVEL METER**

Monitor sound levels to assure worker safety

**WHAT ARE THEY - REASONS TO USE**

**NEX FLOW™** X-Stream™ Sound Level Meters measure and monitor the sound level in all types of industrial environments. Used for compressed air exhaust noise measurement it can identify areas where costly and inefficient blow off can be replaced by energy efficient Nex Flow™ blow off products. In many instances, noise may be reduced using amplification products as much as 10 dBA, to protect workers from excessive and damaging noise levels and reduce energy use.

**Model 91004 Low/High Range Sound Level Meter**  
Dual-range Type 2 digital sound level meter with backlit LCD



**FEATURES:**

- ▶ High accuracy meets ANSI and IEC 651 type 2 standards
- ▶ High and Low measuring ranges
- ▶ Data Hold and Max Hold functions
- ▶ Backlit display to view in dimly lit area
- ▶ Complete with microphone wind screen and 9V Battery

**SPECIFICATIONS:**

- ▶ Display Counts 2000 count LCD
- ▶ Range Low: 35 to 100 dBA
- ▶ High: 65 to 130 dBA
- ▶ Basic Accuracy ±1.5 dBA
- ▶ Weighting (A & C) Yes
- ▶ Response Time (Fast/Slow) Yes
- ▶ Condenser Microphone 0.5" (12.7 mm)
- ▶ Dimensions 8.2x2.1x1.25" (210x55x32 mm)
- ▶ Weight 8.1 Oz (230 gm)

**X-STREAM™ SOUND LEVEL METER**

PART NO.	DESCRIPTION
91004	Standard Sound Level Meter
91005	Sound Meter with data logging

**Model 91005 Data logging Sound Level Meter**  
Stores up to 20,000 records with real date and time Stamp Meets ANSI and IEC61672-1 Type 2 standards



**FEATURES:**

- ▶ 30 to 130 dBA range with 1.4 dBA accuracy
- ▶ Meets ANSI and IEC61672-1 Type 2 standards
- ▶ Data logging capability up to 20,000 records at speed from 1/sec to 1/59sec
- ▶ Capture up to 10 reading/sec when connected to a PC
- ▶ MIN/MAX, Data Hold, Auto power off
- ▶ Built-in USB port, double molded housing with built-in stand
- ▶ Complete with AC adaptor, Windows® compatible software, USB cable, wind cover, tripod, 9V battery and hard carrying case

**SPECIFICATIONS:**

- ▶ Range 30 to 130 dBA
- ▶ Basic accuracy ±1.4 dBA
- ▶ Weighting A and C
- ▶ Response Time Fast/Slow
- ▶ Analog Output AC/DC
- ▶ Data logging 20,000 points
- ▶ PC Interface USB
- ▶ Dimensions 10.9 x 3 x 2" (278 x 76 x 50 mm)
- ▶ Weight 12.3 Oz (350 gm)

**SMART N CLEVER™ OPTIMIZATION PRODUCTS**



**SILENT X-STREAM™ AIR BLADE™ AIR KNIFE**

Blowoff, clean, cool and dry with this quiet, sharp and strong focused curtain of air



**WHAT ARE THEY - REASONS TO USE**

The Silent X-Stream™ Air Blade™ Air Knife is easy to mount and maintain, reducing both compressed air consumption and noise levels. It is the most efficient design yet achieved in Air Knife blow off technology in reducing noise levels and air consumption yet providing the optimum in blow off energy.

The Silent X-Stream™ Air Blade™ Air Knife produces a "laminar" flow of air along its length using the "Coanda" effect which "entrains" a large volume of air from the surrounding area along with a small amount of compressed air from the X-Stream™ Air Blade™ Air Knife to produce an output flow up to 40 times.

System payback on compressed air savings can be as soon as a few weeks in some applications.

The Silent X-Stream™ Air Blade™ Air Knife comes in three versions: Gold Anodized Aluminum for most applications, Hard Anodized aluminum for abrasive environments or where material may come in contact and tend to wear against the air knife, and stainless steel for high temperature and corrosive environments.

**NOTE:** Plastic shims can wear out quickly in Air Knives if the air is not clean. Nex Flow™ uses ONLY stainless steel shims.



**Available in Hard Anodized aluminum for abrasive environments or where material may come in contact with the air knife.**

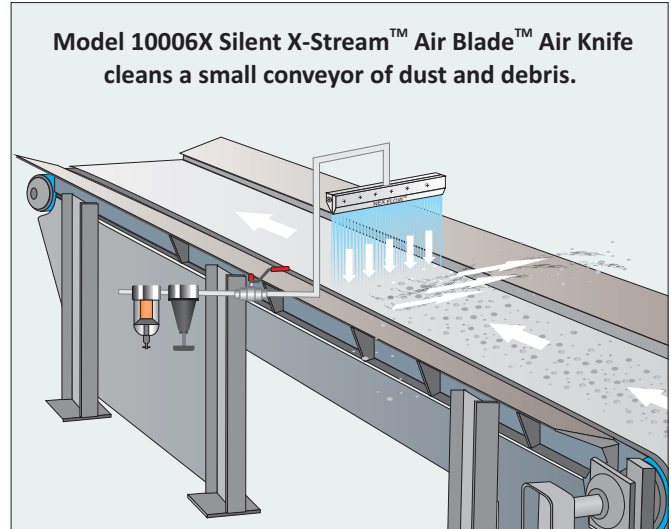

Model 10006X Silent X-Stream™ Air Blade™ Air Knife cleans a small conveyor of dust and debris.

**SILENT X-STREAM™ AIR BLADE™ AIR KNIFE FEATURES:**

- ▶ No moving parts - Gold Anodized aluminum, Hard Anodized aluminum or stainless steel.
- ▶ Compact design, simple, lightweight and portable.
- ▶ Full flow - Air across entire length of Air Knife.
- ▶ Air inlets at ends and back.
- ▶ Driven by air not electricity.
- ▶ Replaces drilled pipe and open jets or nozzles used for blowoff, cleaning, drying and cooling.
- ▶ High airflow amplification.
- ▶ Instant on-off, no electricity or explosion hazard.

**SILENT X-STREAM™ AIR BLADE™ AIR KNIFE BENEFITS:**

- ▶ Longer life in difficult environments than competitive models.
- ▶ Lower compressed air consumption than drilled pipe or rows of open jets and nozzles.
- ▶ Can be placed end to end for continuous airflow.
- ▶ Maintenance free with output easily controlled, safe to use.

**SILENT X-STREAM™ AIR BLADE™ AIR KNIFE ADVANTAGES OVER BLOWERS:**

- ▶ Compact design, simple, lightweight and portable.
- ▶ Driven by air, not electricity for safety.
- ▶ No moving parts - Hence safer and maintenance free.
- ▶ Lower noise levels at 69 dBA and less with smaller space.



**SILENT X-STREAM™ AIR BLADE™ AIR KNIFE APPLICATIONS:**

- ▶ Cleaning of steel sheet in strip mills
- ▶ Parts drying
- ▶ Cleaning or drying web processes.
- ▶ Pre-paint drying and blowoff
- ▶ Scrap removal
- ▶ Parts cooling
- ▶ Circuit board cooling
- ▶ Use for environment separation with air curtain effect
- ▶ Opening bags for filling
- ▶ Sheet separation

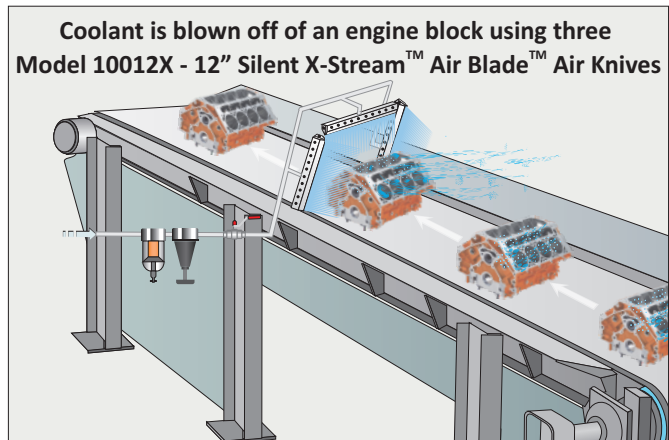

**SILENT X-STREAM™ AIR BLADE™ AIR KNIFE VERSES OTHER BLOWOFF PRODUCTS:**

1. **Drilled Pipe** - Typically drilled pipe uses more compressed air while producing inconsistent flow at high noise levels. The Silent X-Stream™ Air Blade™ Air Knife can usually cut air costs as much as 50%.
2. **Flat Air Nozzles** - These products can use even more compressed air than drilled holes with the same problems of inconsistent flow at high noise levels.
3. **Air Blowers** are capital intensive but can use less energy than compressed air operated air knives on a continual basis. However blowers cannot be cycled on and off quickly and can actually use the same or more energy in intermittent applications. Choosing a blower or Silent X-Stream™ Air Blade™ Air Knife depends on the following factors:
  - (A) **Availability of a particular energy source** - is electricity or air the most convenient.
  - (B) **Space and Weight** - These are important factors that affect the overall cost and maintenance of a system. The compressed air operated Air knife is light weight and compact.
  - (C) **Noise level** - The Silent X-Stream™ Air Blade™ Air Knife is intrinsically quiet while blower systems are noisy and require costly silencing.
  - (D) **Application particulars** - The specific application often determines what is best to use. Intermittent blowoff and/or tight spaces favor the use of the Silent X-Stream™ Air Blade™ Air Knife.
  - (E) **Reliability** - Blower systems require maintenance because they have moving parts. The Silent X-Stream™ Air Blade™ Air Knife requires no maintenance when properly filtered and is intrinsically the most reliable.
  - (F) **Energy Cost** - Energy cost can be less with a blower system especially on continuous blowoff applications. However, energy cost can often be offset against higher capital costs and maintenance costs when utilizing blower systems. The Silent X-stream™ Air Blade™ Air Knife is low cost with negligible maintenance.
  - (G) **System Cost** - Much higher for blower systems especially if silencing is required. It is low for Silent X-Stream™ Air Blade™ Air Knives.
  - (H) **Maintenance and Operating Cost** - The need for maintenance of blower systems can be a strong negative in some situations, especially if the blowers or electrical systems are in harsh environments. The Silent X-Stream™ Air Blade™ Air Knife however is resilient to harsh environments in comparison

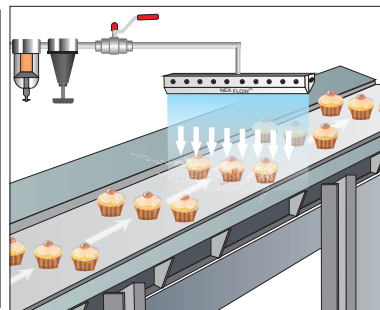
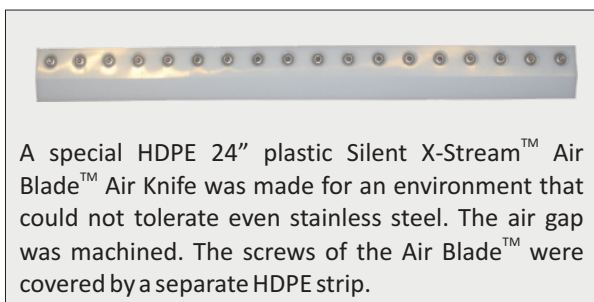

**AIR BLADE™ AIR KNIFE**



**SILENT X-STREAM™ AIR BLADE™ AIR KNIFE - HOW IT WORKS:**

**Silent X-Stream™ Air Blade™ Air Knife** - Compressed air enters the Air Knife at the rear (or end) ports at (A). Air is entrained at point (B) and (D) by the compressed air stream that leaves the Air Knife from a small gap at point (C). The entrained air follows the profile that directs the airflow in a perfect straight line to create a uniform sheet of air along the entire length of the Air Blade™ Air Knife. The amplified air stream maximizes velocity and force is maintained as a well defined sheet of laminar flow with minimal wind shear for reduced energy use in blowoff and cooling.

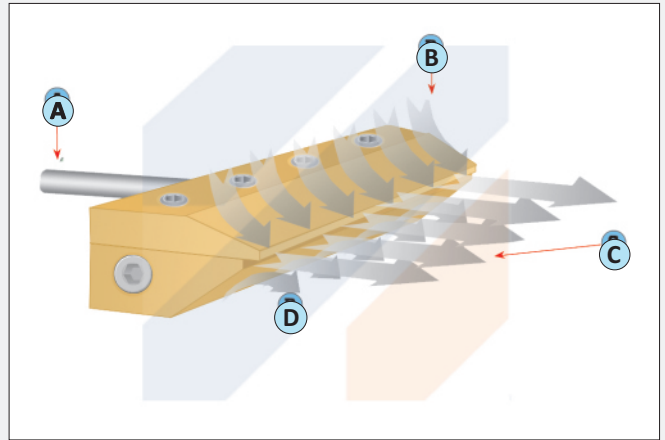

**X-Stream™ Air Blade™ Air Knife** is available in Thirteen (13) standard lengths in Regular Anodized Aluminum, Hard Anodized Aluminum and in Stainless Steel: 2" (51mm), 3" (76mm), 6" (150 mm), 9" (229 mm), 12" (305 mm), 15" (382 mm), 18" (457mm), 24" (610 mm), 30" (761mm), 36" (914mm), 42" (1067mm), 48" (1219 mm) and 54" (1372 mm).

**GOLD ANODIZED AND HARD ANODIZED ALUMINUM SILENT X-STREAM™ AIR BLADE™ AIR KNIFE**

**SIDE VIEW**

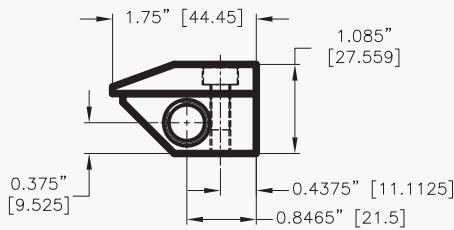

6" to 54" AIR KNIVES ARE PROVIDED WITH ADDITIONAL FLUSH PLUGS FOR UNUSED PORTS

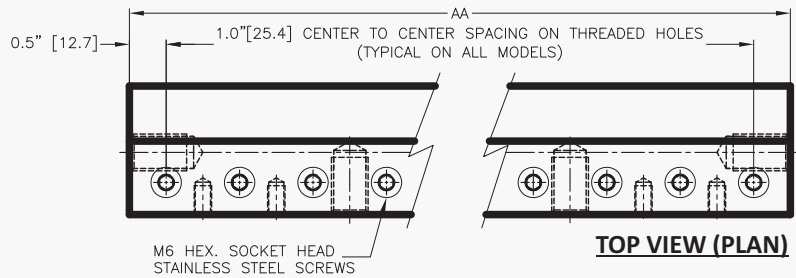

M6 THREADED THRU HOLES CAN BE USED AS ALTERNATIVE MOUNTING HOLES

**STAINLESS STEEL SILENT X-STREAM™ AIR BLADE™ AIR KNIFE**

**SIDE VIEW**

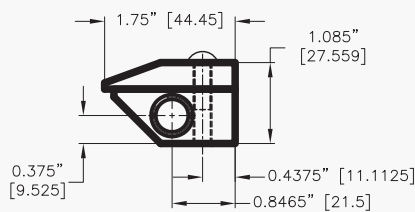

6" to 54" AIR KNIVES ARE PROVIDED WITH ADDITIONAL FLUSH PLUGS FOR UNUSED PORTS

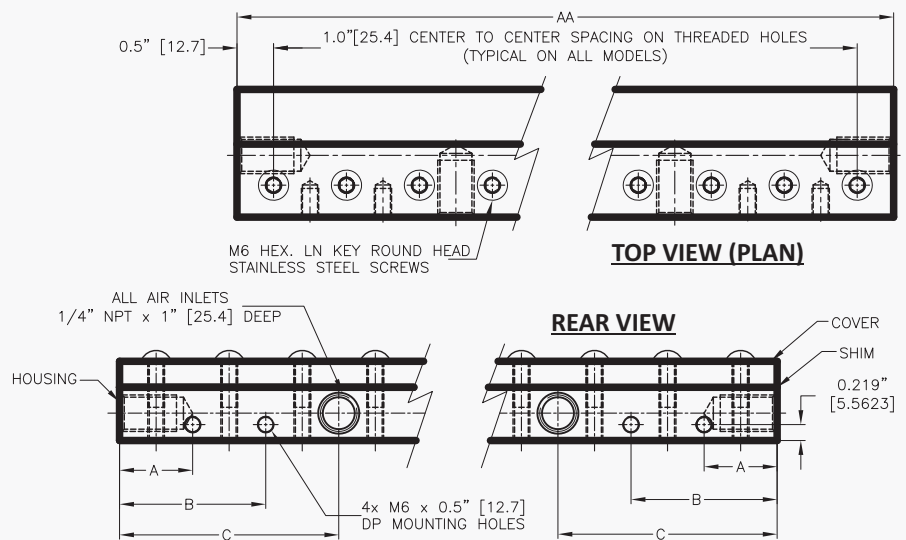

(\* BSP Threads or Adaptors can be supplied depending on country location)

**DIMENSION TABLE OF SILENT X-STREAM™ AIR BLADE™ AIR KNIFE – GOLD ANODIZED ALUMINUM**

PART NO. (Stainless Steel)	AA Inches (mm)	A Inches (mm)	B Inches (mm)	C Inches (mm)	No. of Rear Inlets (Side Inlets)
Model 10002X Gold Anodized Aluminum	2"(50.8)	N/A	N/A	1"(25.4)	1(0)
Model 10003X Gold Anodized Aluminum	3"(76.2)	.641"(16.3)	N/A	1.5"(38.1)	1(0)
Model 10006X Gold Anodized Aluminum	6"(152)	1"(25.4)	2"(50.8)	3"(76.2)	1(2)
Model 10009X Gold Anodized Aluminum	9"(228.6)	1"(25.4)	2"(50.8)	3"(76.2)	2(2)
Model 10012X Gold Anodized Aluminum	12"(304.8)	1"(25.4)	2"(50.8)	3"(76.2)	2(2)
Model 10015X Gold Anodized Aluminum	15"(381)	1"(25.4)	2"(50.8)	4"(101.6)	2(2)
Model 10018X Gold Anodized Aluminum	18"(457.2)	1"(25.4)	2"(50.8)	5"(127.0)	2(2)
Model 10024X Gold Anodized Aluminum	24"(609.6)	1"(25.4)	2"(50.8)	6"(152.4)	2(2)
Model 10030X Gold Anodized Aluminum	30"(762)	1"(25.4)	2"(50.8)	6"(152.4)	2(2)
Model 10036X Gold Anodized Aluminum	36"(914.4)	1"(25.4)	2"(50.8)	6"(152.4)	2(2)
Model 10042X Gold Anodized Aluminum	42"(1066.8)	1"(25.4)	2"(50.8)	6"(152.4)	2(2)
Model 10048X Gold Anodized Aluminum	48"(1219.2)	1"(25.4)	2"(50.8)	9"(228.6)	3(2)
Model 10054X Gold Anodized Aluminum	54"(1371.6)	1"(25.4)	2"(50.8)	9"(228.6)	3(2)

**NOTE:** For sizes 48" and longer there is a third rear inlet port in the middle, 1/4" NPT on same level as the other two rear inlet ports.

**USE OF SHIMS:**

Nex Flow™ uses **ONLY** stainless steel shims in their Air Knife products as plastic shims wear out over time and require replacement, even with relatively clean air systems. Stainless steel shims are .002" (.050 mm). In most applications this is adequate. However, velocity and force can be increased approximately 30% by adding a second .002" (.050 mm) shim. Shims may be stacked up to 5 sets. If using three or more sets however, the air inlets at the "ends" should be used to maintain even flow along the Air Knife system. Otherwise a slight drop in pressure and flow will occur across from the rear inlet ports if they are used with three or more shims. Note that noise levels and air use will go up with an increased number of shims.

**MOUNTING:**

Mounting holes are provided for easy mounting of the Silent X-Stream™ Air Blade™. In addition, the holes at the bottom of the unit may also be used for mounting.

**SPECIAL AIR KNIVES:**

Do you need a special length? Do you need a different shape or profile or material? Nex Flow™ can supply special units and address any unique situation. We have produced special lengths and made Air Knives in HDPE and other materials as requested.

**ACCESSORIES:**

It is important to keep the air supply clean and dry. We recommend a water removal filter with a float type automatic drain with a minimum filtration of 5 micron. If there is a chance of oil in the lines, we suggest an oil removal filter as well with a minimum filtration of 0.3 micron, also with an automatic drain. To minimize air use, we recommend a regulator with gauge to set the minimum pressure necessary to operate the system. If the system can be turned on and off as necessary, we recommend a system such as our PLCFC System as described in Section A.

## HARD ANODIZED SILENT X-STREAM™ AIR BLADE™ AIR KNIFE

Blowoff, clean, cool and dry with this quietly in sticky, abrasive environments.



### WHAT ARE THEY - REASONS TO USE

The Hard Anodized version of the Silent X-Stream™ Air Blade™ Air Knife is just as easy to mount and maintain, reducing both compressed air consumption and noise levels. It has the extra benefit of a protective coating that is more resistant to sticky material such as floating oils and has excellent resistance to abrasive action such as materials that could rub onto, or brush against the air knife in production. As with the regular anodized versions, it is still the most efficient design yet achieved in Air Knife blow off technology in reducing noise levels and air consumption yet providing the optimum in blow off energy.

The Hard Anodized Silent X-Stream™ Air Blade™ Air Knife produces a “laminar” flow of air along its length using the “Coanda” effect which “entrains” a large volume of air from the surrounding area along with a small amount of compressed air from the X-Stream™ Air Blade™ Air Knife to produce an output flow of up to 40 times.

System payback on compressed air savings can be as soon as a few weeks in some applications.

**NOTE:** Plastic shims can wear out quickly in Air Knives if the air is not clean. Nex Flow™ uses ONLY stainless steel shims.

### HARD ANODIZED SILENT X-STREAM™ AIR BLADE™ AIR KNIFE FEATURES:

- ▶ No moving parts - Gold Anodized aluminum, Hard Anodized aluminum or stainless steel.
- ▶ Compact design, simple, lightweight and portable.
- ▶ Full flow - Air across entire length of Air Knife.
- ▶ Air inlets at ends and back.
- ▶ Driven by air not electricity.
- ▶ Replaces drilled pipe and open jets or nozzles used for blowoff, cleaning, drying and cooling.
- ▶ High airflow amplification.
- ▶ Instant on-off, no electricity or explosion hazard.

### HARD ANODIZED SILENT X-STREAM™ AIR BLADE™ AIR KNIFE BENEFITS:

- ▶ Longer life in difficult environments than competitive models.
- ▶ Lower compressed air consumption than drilled pipe or rows of open jets and nozzles.
- ▶ Can be placed end to end for continuous airflow.
- ▶ Maintenance free with output easily controlled, safe to use.

### HARD ANODIZED SILENT X-STREAM™ AIR BLADE™ AIR KNIFE ADVANTAGES OVER BLOWERS:

- ▶ Compact design, simple, lightweight and portable.
- ▶ Driven by air, not electricity for safety.
- ▶ No moving parts - Hence safer and maintenance free.
- ▶ Lower noise levels at 69 dBA and less with smaller space.



Just as we can provide special air knives made of different materials such as the HDPE plastic Silent X-Stream™ Air Blade™ shown, Nex Flow™ can provide special coatings to address specific applications and environments.



**DIMENSION TABLE OF SILENT X-STREAM™ AIR BLADE™ AIR KNIFE – HARD ANODIZED ALUMINUM**

PART NO. (Stainless Steel)	AA Inches (mm)	A Inches (mm)	B Inches (mm)	C Inches (mm)	No. of Rear Inlets (Side Inlets)
Model 10002XHA Hard Anodized Aluminum	2"(50.8)	N/A	N/A	1"(25.4)	1(0)
Model 10003XHA Hard Anodized Aluminum	3"(76.2)	.641"(16.3)	N/A	1.5"(38.1)	1(0)
Model 10006XHA Hard Anodized Aluminum	6"(152)	1"(25.4)	2"(50.8)	3"(76.2)	1(2)
Model 10009XHA Hard Anodized Aluminum	9"(228.6)	1"(25.4)	2"(50.8)	3"(76.2)	2(2)
Model 10012XHA Hard Anodized Aluminum	12"(304.8)	1"(25.4)	2"(50.8)	3"(76.2)	2(2)
Model 10015XHA Hard Anodized Aluminum	15"(381)	1"(25.4)	2"(50.8)	4"(101.6)	2(2)
Model 10018XHA Hard Anodized Aluminum	18"(457.2)	1"(25.4)	2"(50.8)	5"(127.0)	2(2)
Model 10024XHA Hard Anodized Aluminum	24"(609.6)	1"(25.4)	2"(50.8)	6"(152.4)	2(2)
Model 10030XHA Hard Anodized Aluminum	30"(762)	1"(25.4)	2"(50.8)	6"(152.4)	2(2)
Model 10036XHA Hard Anodized Aluminum	36"(914.4)	1"(25.4)	2"(50.8)	6"(152.4)	2(2)
Model 10042XHA Hard Anodized Aluminum	42"(1066.8)	1"(25.4)	2"(50.8)	6"(152.4)	2(2)
Model 10048XHA Hard Anodized Aluminum	48"(1219.2)	1"(25.4)	2"(50.8)	9"(228.6)	3(2)
Model 10054XHA Hard Anodized Aluminum	54"(1371.6)	1"(25.4)	2"(50.8)	9"(228.6)	3(2)

**NOTE:** For sizes 48" and longer there is a third rear inlet port in the middle, 1/4" NPT on same level as the other two rear inlet ports.

**USE OF SHIMS:** Nex Flow™ uses **ONLY** stainless steel shims in their Air Knife products as plastic shims wear out over time and require replacement, even with relatively clean air systems. Stainless steel shims are .002" (.050 mm). In most applications this is adequate. However, velocity and force can be increased approximately 30% by adding a second .002" (.050 mm) shim. Shims may be stacked up to 5 sets. If using three or more sets however, the air inlets at the "ends" should be used to maintain even flow along the Air Knife system. Otherwise a slight drop in pressure and flow will occur across from the rear inlet ports if they are used with three or more shims. Note that noise levels and air use will go up with an increased number of shims.

**MOUNTING:** Mounting holes are provided for easy mounting of the Silent X-Stream™ Air Blade™. In addition, the holes at the bottom of the unit may also be used for mounting.

**SPECIAL AIR KNIVES:** Do you need a special length? Do you need a different shape or profile or material? Nex Flow™ can supply special units and address any unique situation. We have produced special lengths and made Air Knives in HDPE and other materials as requested.

**ACCESSORIES:** It is important to keep the air supply clean and dry. We recommend a water removal filter with a float type automatic drain with a minimum filtration of 5 micron. If there is a chance of oil in the lines, we suggest an oil removal filter as well with a minimum filtration of 0.3 micron, also with an automatic drain. To minimize air use, we recommend a regulator with gauge to set the minimum pressure necessary to operate the system. If the system can be turned on and off as necessary, we recommend a system such as our PLCFC System as described in Section A.





**DIMENSION TABLE OF SILENT X-STREAM™ AIR BLADE™ AIR KNIFE – STAINLESS STEEL**

PART NO. (Stainless Steel)	AA Inches (mm)	A Inches (mm)	B Inches (mm)	C Inches (mm)	No. of Rear Inlets (Side Inlets)
Model 10002XS stainless	2"(50.8)	N/A	N/A	1"(25.4)	1(0)
Model 10003XS stainless	3"(76.2)	.641"(16.3)	N/A	1.5"(38.1)	1(0)
Model 10006XS stainless	6"(152)	1"(25.4)	2"(50.8)	3"(76.2)	1(2)
Model 10009XS stainless	9"(228.6)	1"(25.4)	2"(50.8)	3"(76.2)	2(2)
Model 10012XS stainless	12"(304.8)	1"(25.4)	2"(50.8)	3"(76.2)	2(2)
Model 10015XS stainless	15"(381)	1"(25.4)	2"(50.8)	4"(101.6)	2(2)
Model 10018XS stainless	18"(457.2)	1"(25.4)	2"(50.8)	5"(127.0)	2(2)
Model 10024XS stainless	24"(609.6)	1"(25.4)	2"(50.8)	6"(152.4)	2(2)
Model 10030XS stainless	30"(762)	1"(25.4)	2"(50.8)	6"(152.4)	2(2)
Model 10036XS stainless	36"(914.4)	1"(25.4)	2"(50.8)	6"(152.4)	2(2)
Model 10042XS stainless	42"(1066.8)	1"(25.4)	2"(50.8)	6"(152.4)	2(2)
Model 10048XS stainless	48"(1219.2)	1"(25.4)	2"(50.8)	9"(228.6)	3(2)
Model 10054XS stainless	54"(1371.6)	1"(25.4)	2"(50.8)	9"(228.6)	3(2)

**USE OF SHIMS:**

Nex Flow™ uses **ONLY** stainless steel shims in their Air Knife products as plastic shims wear out over time and require replacement, even with relatively clean air systems. Stainless steel shims are .002" (.050 mm). In most applications this is adequate. However, velocity and force can be increased approximately 30% by adding a second .002" (.050 mm) shim. Shims may be stacked up to 5 sets. If using three or more sets however, the air inlets at the "ends" should be used to maintain even flow along the Air Knife system. Otherwise a slight drop in pressure and flow will occur across from the rear inlet ports if they are used with three or more shims. Note that noise levels and air use will go up with an increased number of shims.

**MOUNTING:**

Mounting holes are provided for easy mounting of the Silent X-Stream™ Air Blade™. In addition, the holes at the bottom of the unit may also be used for mounting.

**SPECIAL AIR KNIVES:**

Do you need a special length? Do you need a different shape or profile or material? Nex Flow™ can supply special units and address any unique situation. We have produced special lengths and made Air Knives in HDPE and other materials as requested.

**ACCESSORIES:**

It is important to keep the air supply clean and dry. We recommend a water removal filter with a float type automatic drain with a minimum filtration of 5 micron. If there is a chance of oil in the lines, we suggest an oil removal filter as well with a minimum filtration of 0.3 micron, also with an automatic drain. To minimize air use, we recommend a regulator with gauge to set the minimum pressure necessary to operate the system. If the system can be turned on and off as necessary, we recommend a system such as our PLCFC System as described in Section A.



**Inlet Pressure Upstream vs. Air Consumption Per Inch for Silent X-Stream™ Air Blade™ Air Knife**

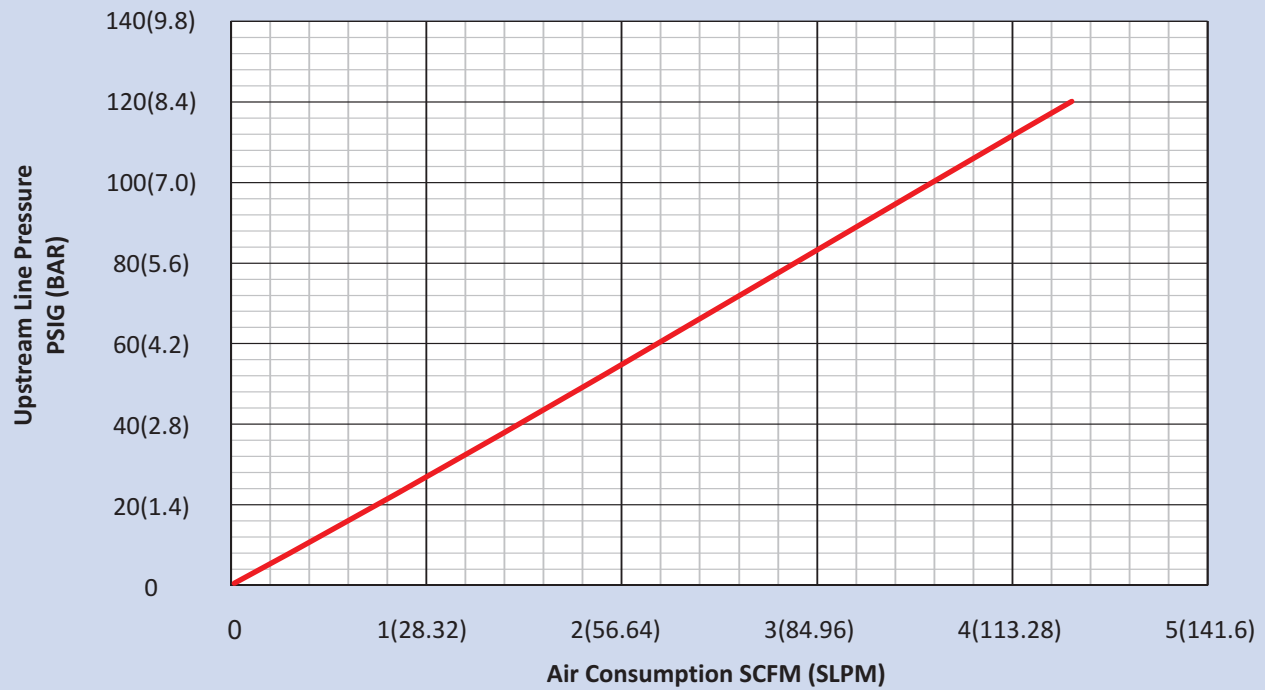

NOTE: Tests were performed using a 12" Model 10012X Silent X-Stream™ Air Blade™ Air Knife

**Inlet Pressure Upstream vs. Sound level at 3 feet (0.91m) for Silent X-Stream™ Air Blade™ Air Knife**

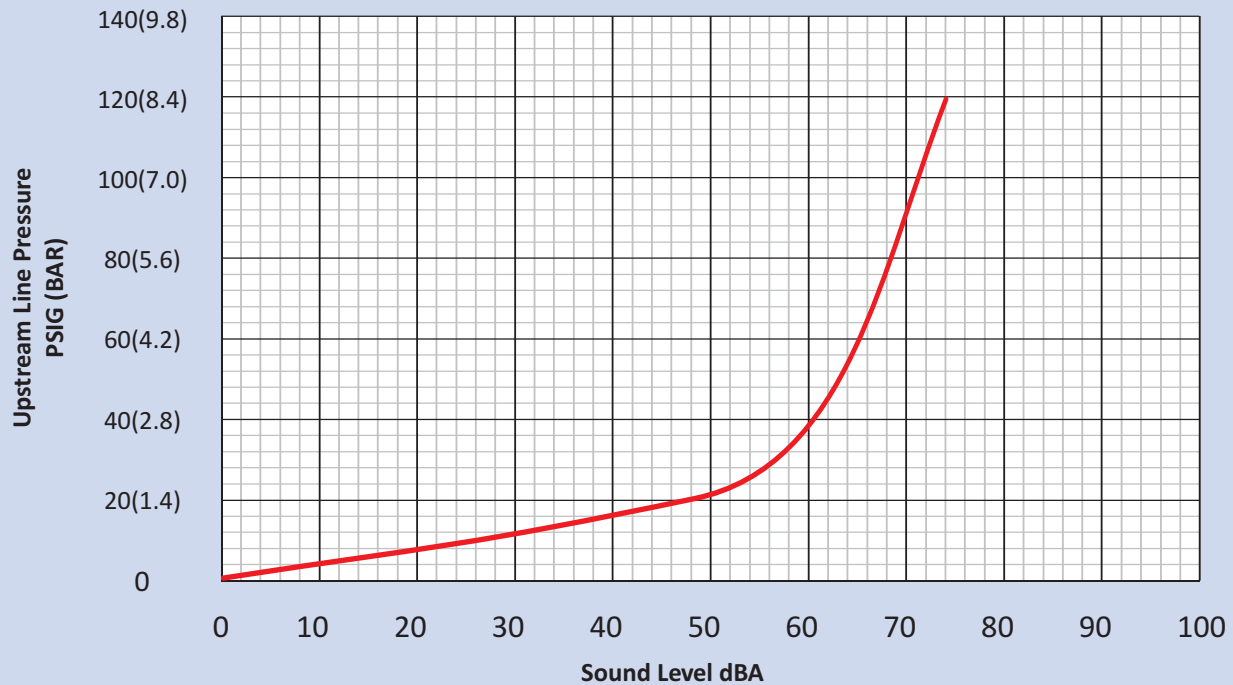

NOTE: Tests were performed using a 12" Model 10012X Silent X-Stream™ Air Blade™ Air Knife

**AIR BLADE™ AIR KNIFE**



**B  
8**

**Actual Force Per Inch for Silent X-Stream™ Air Blade™ Air Knife**

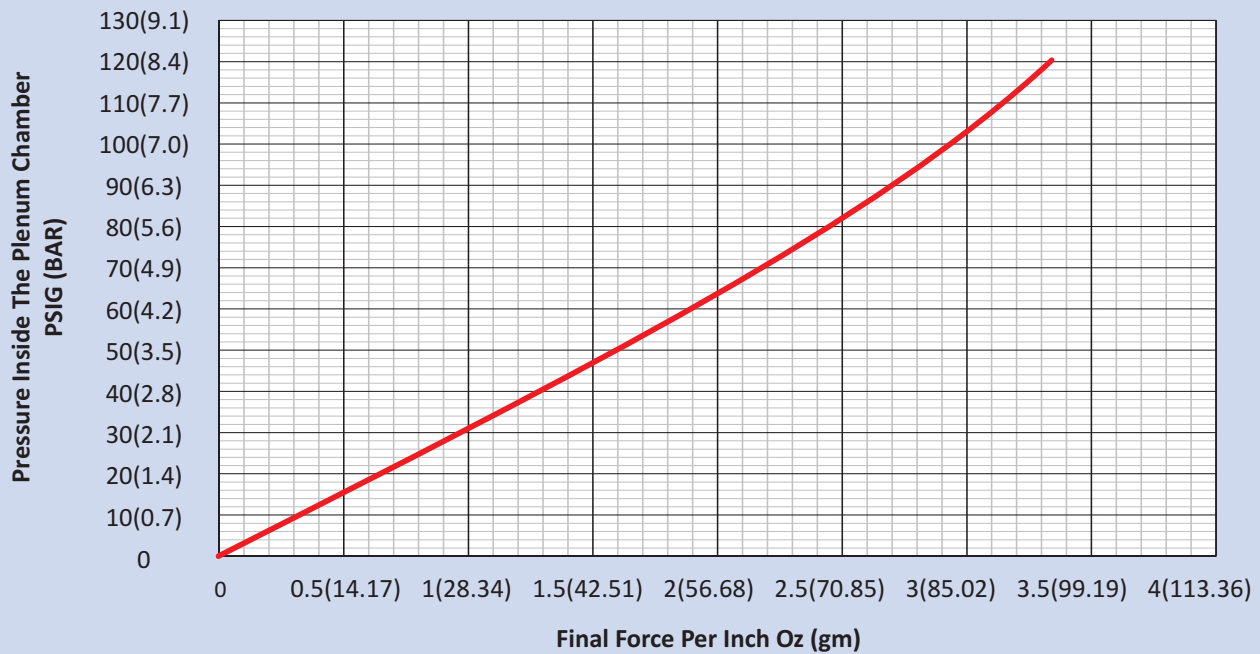

**NOTE:**

Force per inch of Air Knife was based on tests done with a 12" Silent X-Stream™ Air Blade™ Air Knife with a .002" (.050 mm) gap. Force was measured at a target 6" from the Air Knife.

*Actual results may vary due to tolerance variations.*

*Estimate 30% more force with a .004" (.100 mm) gap.*

**FORCE PER INCH EXPLANATION**

The pressure is measured at the chamber inside the X-Stream™ Air Blade™ Air Knife and not upstream. The force per inch is from tests using a 12" X-Stream™ Air Blade™ Air Knife with the graph extrapolated for higher end pressures. Figures will vary with the length of the Air Knife. The longer the Air Knife, the less the chamber pressure will be and the force per inch will also decrease. This is because of the limited size and volume of the chamber and also because of the limited air inlet holes.

Estimated chamber pressure inside the X-Stream™ Air Blade™ Air Knife as a percentage of upstream line pressure can be reasonably estimated as follows. Size of air lines, upstream pressure, and piping configurations can cause a great variation in actual force produced and actual pressure formed in the chamber of the Air Knife. However, for general engineering applications the multiplication factors as shown in the graph "Multiplication Factors to Obtain Plenum Pressure for Silent X-Stream™ Air Blade™ Air Knife" can be used to estimate the plenum pressure. Then you can obtain the force per inch from the Actual Force per inch graph.

- ▶ In general, the force per inch will be greater for shorter length X-Stream™ Air Blade™ Air Knives.
- ▶ If a particular application requires a greater force, it may be more useful to have several smaller length air knives than one larger one.

**EXAMPLE:**

Two (2) 12" X-Stream™ Air Blade™ Air Knives with a line pressure of 80 psig can be estimated to have a chamber pressure of 0.90 times the line pressure or  $0.9 \times 80 = 72$  psig. The force per inch from the Force graph at 72 psig is about 2.2 oz per inch for a total of  $2.2 \times 24 = 48$  oz force.

One (1) 24" X-Stream™ Air Blade™ Air Knife with a line pressure of 80 psig can be estimated to have a chamber pressure of 0.70 times the line pressure of  $0.7 \times 80 = 56$  psig.

The force per inch from the Force graph at 56 psig is  $1.8 \times 24 = 43$  oz force.

**In most applications a single 24" Air Knife will work but in applications where force is critical, it can make sense to use several smaller Air Knives instead.**



**Multiplication Factors to Obtain Plenum Pressure for Silent X-Stream™ Air Blade™ Air Knife**

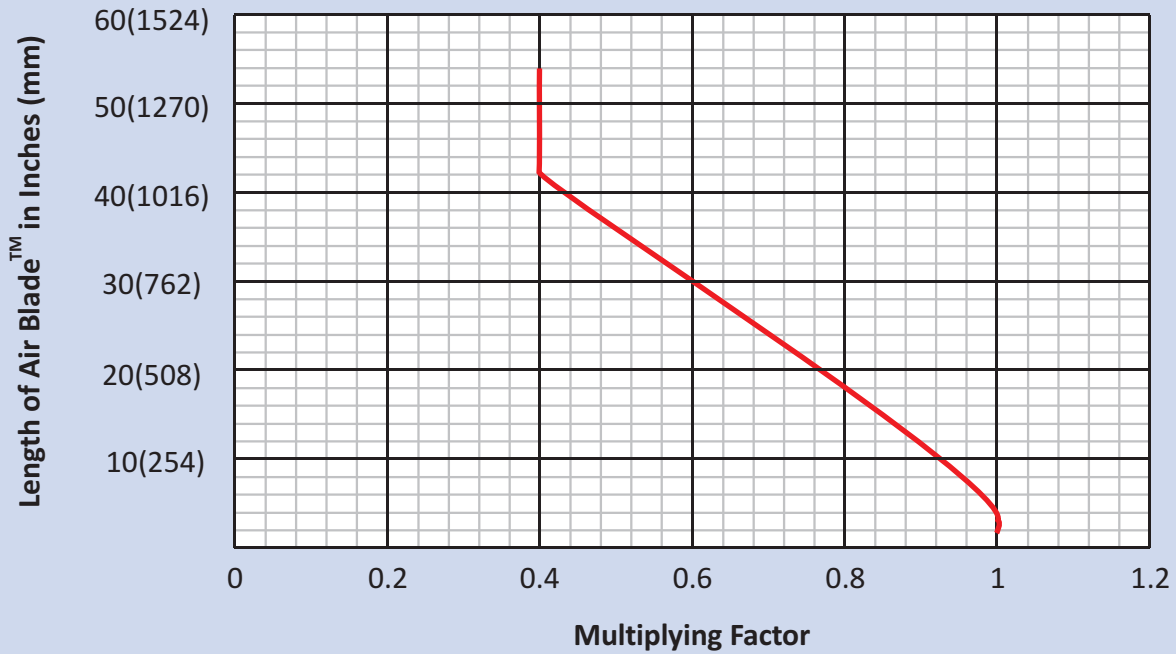

**NOTE:** These multipliers are based on having a large compressed air supply with air lines in the 1" range and with the location of use mid-plant. If the location is near the end of a long air line run, if there is a heavy use load and if air lines are small the multiplier can be reduced as much as 50%.

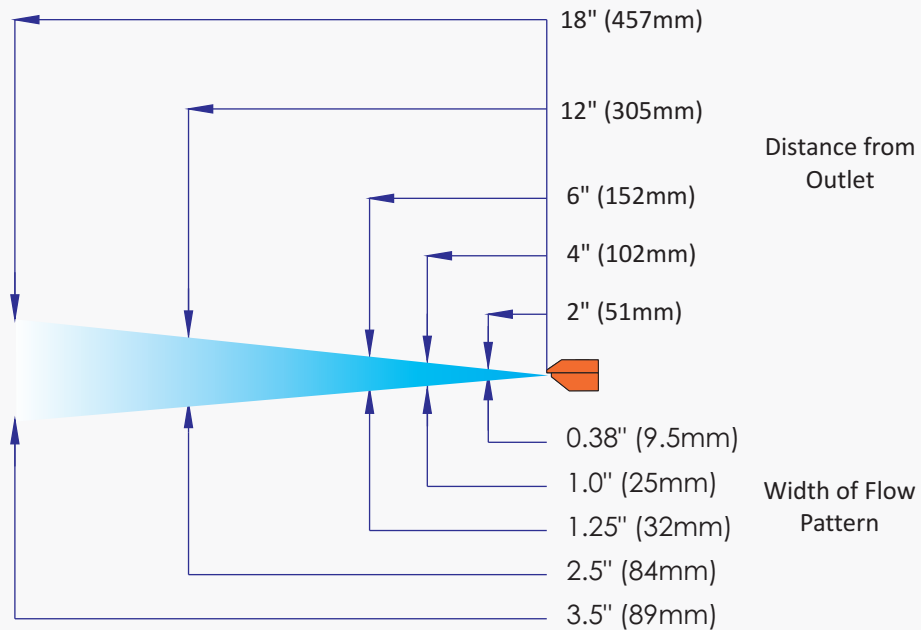

**SUPER QUIET, SUPER CONCENTRATED KNIFE EDGE AIR STREAM**  
**PROFILE OF SILENT X-STREAM™ AIR BLADE™ AIR KNIFE**

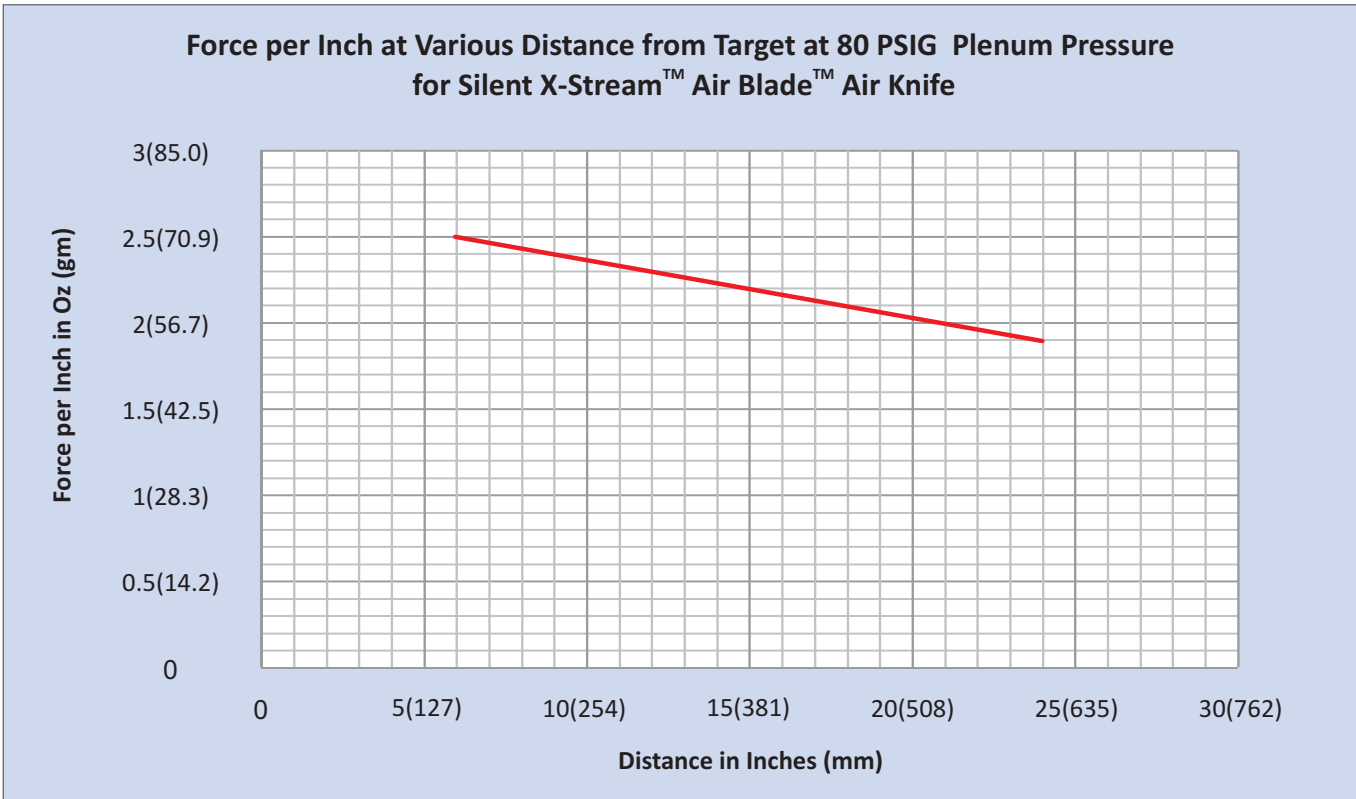

**NOTE:** Tests were performed using a 12" Model 10012X Silent X-Stream™ Air Blade™ Air Knife

**ACCESSORIES**

It is important to keep the air supply clean and dry. We recommend a water removal filter with a float type automatic drain with a minimum filtration of 5 micron. If there is a chance of oil in the lines, we suggest an oil removal filter as well with a minimum filtration of 0.3 micron, also with an automatic drain.

To minimize air use, we recommend a regulator with gauge to set the minimum pressure necessary to operate the system. If the system can be turned on and off as necessary, we recommend a system such as our PLCFC System as described in Section A.

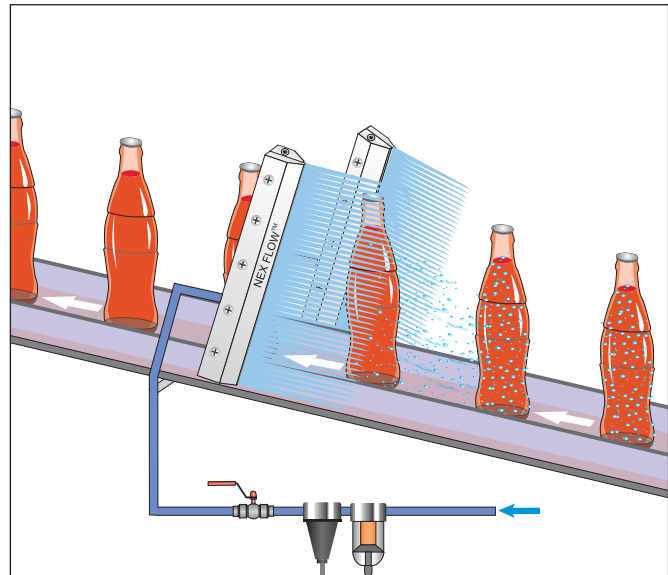

**OPTIONAL SILENT X-STREAM™ AIR BLADE™ AIR KNIFE COUPLING KIT.**



This one piece kit c/w 10 stainless steel screws connects any two Silent X-Stream™ Air Blade™ Air Knife of 6" or larger together to make a longer blowoff system to cover greater distances. The units come in three models. Model 10900X gold anodized aluminum for the gold anodized aluminum Silent X-Stream™ Air Blade™ Air Knives, Model 10900XHA for the Hard Anodized units, and Model 10900XS stainless for stainless steel models.

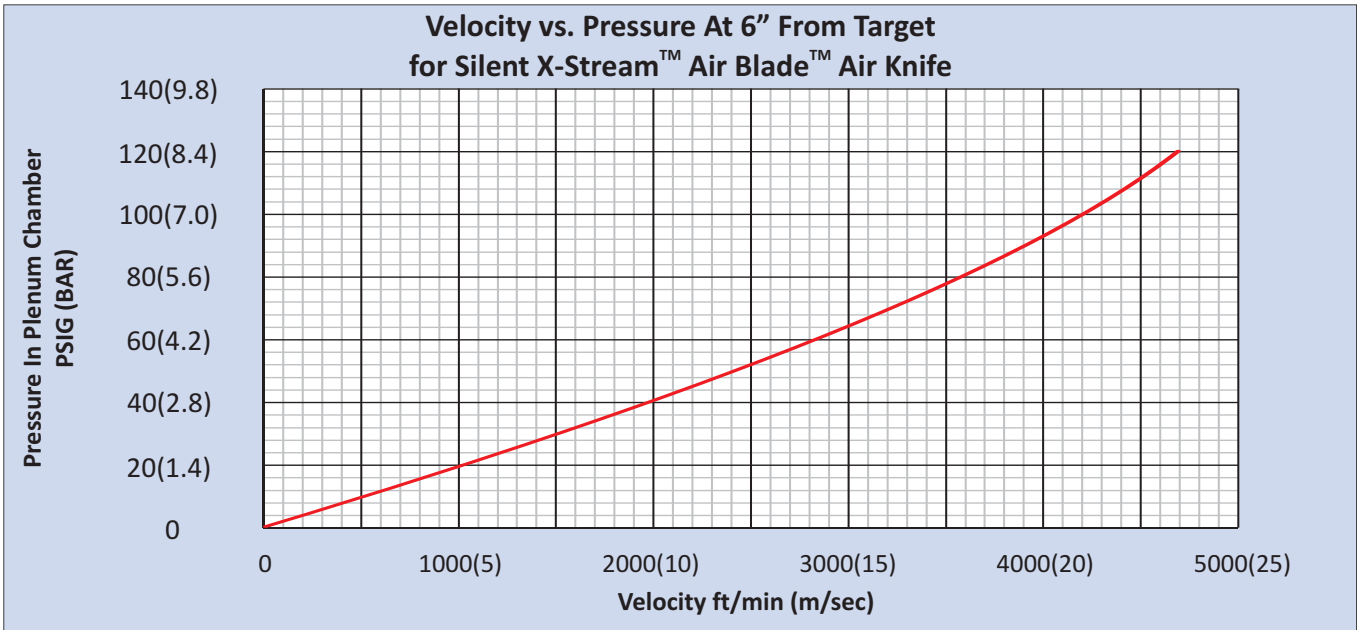

**NOTE:** Tests were performed using a 12" Model 10012X Silent X-Stream™ Air Blade™ Air Knife

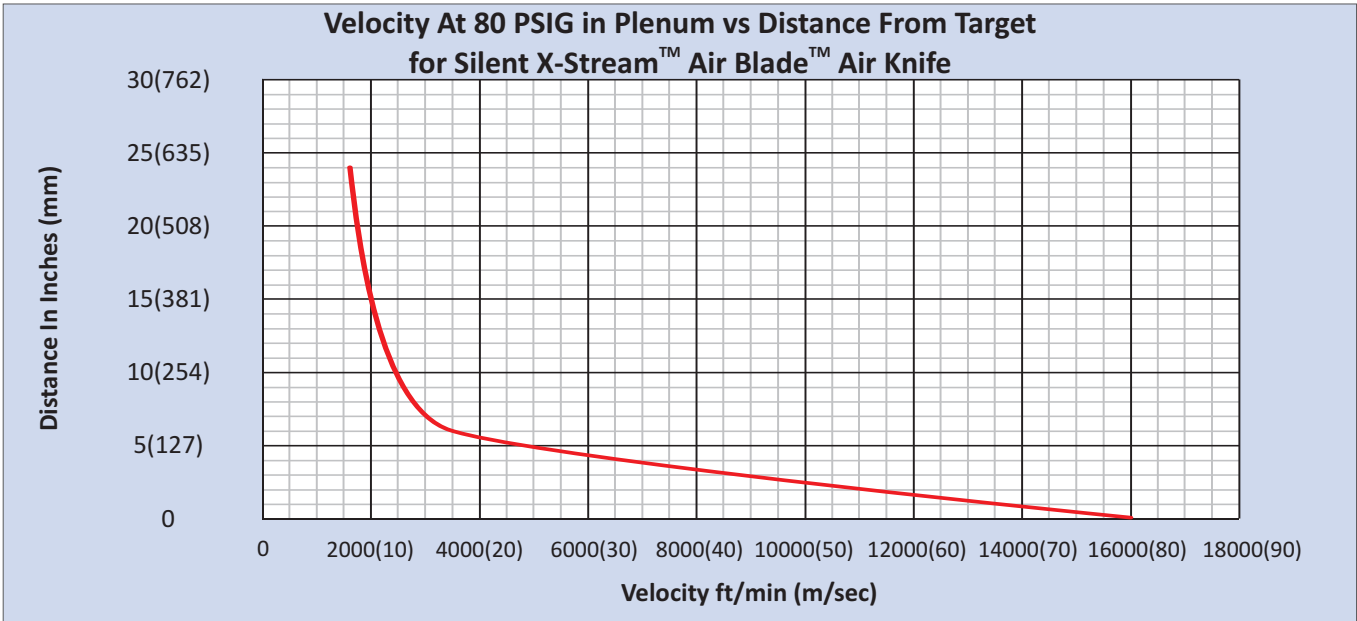

**NOTE:** Tests were performed using a 12" Model 10012X Silent X-Stream™ Air Blade™ Air Knife

Velocity is important in that it can determine the cooling effect and is also related to the blowoff force. Velocity will vary significantly depending on the temperature of the ambient air - The hotter the air, the greater the velocity (and the greater the amplification of the air flow). So velocity figures at best are an approximation. As air is entrained, the flow increases and as the flow increases the velocity must come down. The velocity at the exit of the Silent X-Stream™ Air Blade™ Air Knife is the highest but the figure is of no value as once the surrounding air is entrained, the velocity drops dramatically. (Be wary of extremely high velocity claims downstream of any Air Knife or Air Amplifier). The figures provided by Nex Flow™ can be verified with a velocity meter. There will be some variations in measurement due to different air pressure and atmospheric conditions. The velocity is, among other things, dependent on the chamber pressure. That pressure in turn depends upon pipe size, pressure drops in the system, distance from the compressor station to the point of use, and many other factors. (See previous pages regarding plenum chamber pressure and force estimates).



**CALCULATING AIR SAVINGS**

The chart below shows the air consumption at different upstream air inlet pressures for various hole sizes and the air consumption per inch of a Silent X-Stream™ Air Blade™ Air Knife.

To obtain the air consumption of drilled holes in pipe determine the size of the holes and multiply the air loss by the number of holes over the length.

The air usage of the Silent X-stream™ Air Blade™ Air Knife is per inch. Multiply the figure from the chart by the length of the air knife.

**EXAMPLE:**

Assume an existing blowoff of a 24" long pipe with 3/32" holes spaced 3/4" inches apart for a total of 32 holes. At 80 PSIG from the graph each hole consumes about 9.4 SCFM for a total of 32 X 9.4 = 300.8 SCFM

At 80 PSIG a 24" X-Stream™ Air Blade™ Air Knife consumes 24 X 2.9 SCFM/inch = 69.6 SCFM

Compressed air saved is 300.8 - 69.6 = 231.2 SCFM

Using actual air costs if known (or assuming a reasonable cost of \$.30 US per 1000 cubic feet) the dollars saved is 231.2 X 60 X 0.30/1000 = \$4.16 /hr or assuming an 2000 hour working year = \$8320.00 SAVED PER YEAR

Please refer to the Addendum on the explanation of Air Flow Amplification for a detailed explanation on what it is and how air amplification works.

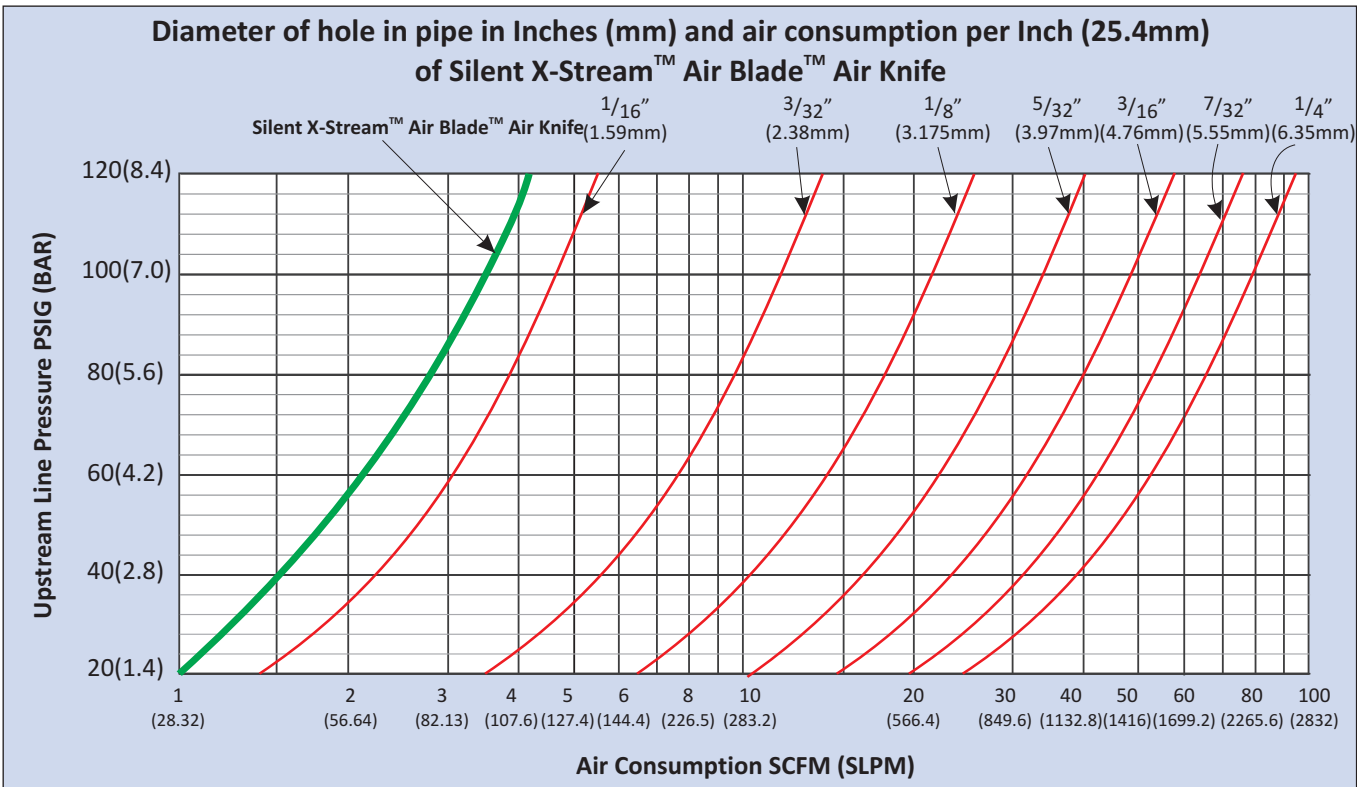
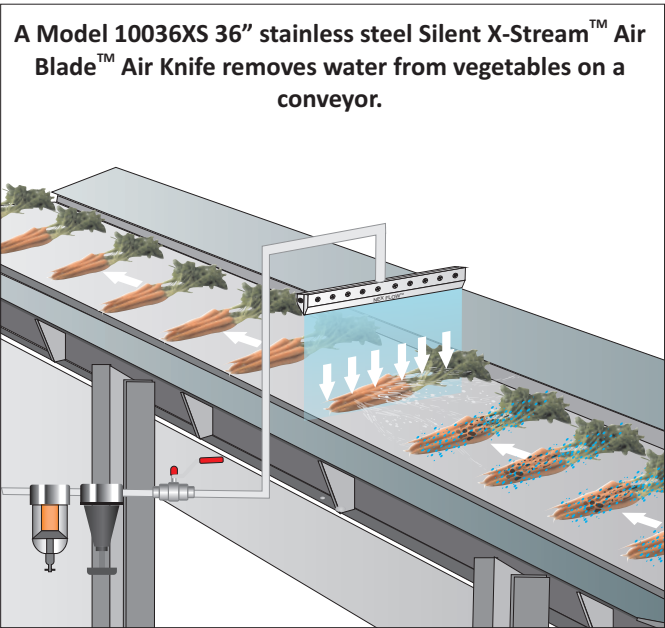

**Gold Anodized Aluminum X-Stream™ Full-Flow Air Blade™ Air Knives**

PART NO.	DESCRIPTION
10002X	2" Gold Anodized Alum. X-Stream™ Air Blade™ Air Knife Only
10003X	3" Gold Anodized Alum. X-Stream™ Air Blade™ Air Knife Only
10006X	6" Gold Anodized Alum. X-Stream™ Air Blade™ Air Knife Only
10009X	9" Gold Anodized Alum. X-Stream™ Air Blade™ Air Knife Only
10012X	12" Gold Anodized Alum. X-Stream™ Air Blade™ Air Knife Only
10015X	15" Gold Anodized Alum. X-Stream™ Air Blade™ Air Knife Only
10018X	18" Gold Anodized Alum. X-Stream™ Air Blade™ Air Knife Only
10024X	24" Gold Anodized Alum. X-Stream™ Air Blade™ Air Knife Only
10030X	30" Gold Anodized Alum. X-Stream™ Air Blade™ Air Knife Only
10036X	36" Gold Anodized Alum. X-Stream™ Air Blade™ Air Knife Only
10042X	42" Gold Anodized Alum. X-Stream™ Air Blade™ Air Knife Only
10048X	48" Gold Anodized Alum. X-Stream™ Air Blade™ Air Knife Only
10054X	54" Gold Anodized Alum. X-Stream™ Air Blade™ Air Knife Only
11002X	2" Gold Anodized Alum. X-Stream™ Air Blade™ Air Knife plus Filter with Auto Drain
11003X	3" Gold Anodized Alum. X-Stream™ Air Blade™ Air Knife plus Filter with Auto Drain
11006X	6" Gold Anodized Alum. X-Stream™ Air Blade™ Air Knife plus Filter with Auto Drain
11009X	9" Gold Anodized Alum. X-Stream™ Air Blade™ Air Knife plus Filter with Auto Drain
11012X	12" Gold Anodized Alum. X-Stream™ Air Blade™ Air Knife plus Filter with Auto Drain
11015X	15" Gold Anodized Alum. X-Stream™ Air Blade™ Air Knife plus Filter with Auto Drain
11018X	18" Gold Anodized Alum. X-Stream™ Air Blade™ Air Knife plus Filter with Auto Drain
11024X	24" Gold Anodized Alum. X-Stream™ Air Blade™ Air Knife plus Filter with Auto Drain
11030X	30" Gold Anodized Alum. X-Stream™ Air Blade™ Air Knife plus Filter with Auto Drain
11036X	36" Gold Anodized Alum. X-Stream™ Air Blade™ Air Knife plus Filter with Auto Drain
11042X	42" Gold Anodized Alum. X-Stream™ Air Blade™ Air Knife plus Filter with Auto Drain
11048X	48" Gold Anodized Alum. X-Stream™ Air Blade™ Air Knife plus Filter with Auto Drain
11054X	54" Gold Anodized Alum. X-Stream™ Air Blade™ Air Knife plus Filter with Auto Drain
12002X	2" Gold Anodized Alum. X-Stream™ Air Blade™ Air Knife + Filter with Auto Drain + Regulator with Gauge
12003X	3" Gold Anodized Alum. X-Stream™ Air Blade™ Air Knife + Filter with Auto Drain + Regulator with Gauge
12006X	6" Gold Anodized Alum. X-Stream™ Air Blade™ Air Knife + Filter with Auto Drain + Regulator with Gauge
12009X	9" Gold Anodized Alum. X-Stream™ Air Blade™ Air Knife + Filter with Auto Drain + Regulator with Gauge
12012X	12" Gold Anodized Alum. X-Stream™ Air Blade™ Air Knife + Filter with Auto Drain + Regulator with Gauge
12015X	15" Gold Anodized Alum. X-Stream™ Air Blade™ Air Knife + Filter with Auto Drain + Regulator with Gauge
12018X	18" Gold Anodized Alum. X-Stream™ Air Blade™ Air Knife + Filter with Auto Drain + Regulator with Gauge
12024X	24" Gold Anodized Alum. X-Stream™ Air Blade™ Air Knife + Filter with Auto Drain + Regulator with Gauge
12030X	30" Gold Anodized Alum. X-Stream™ Air Blade™ Air Knife + Filter with Auto Drain + Regulator with Gauge
12036X	36" Gold Anodized Alum. X-Stream™ Air Blade™ Air Knife + Filter with Auto Drain + Regulator with Gauge
12042X	42" Gold Anodized Alum. X-Stream™ Air Blade™ Air Knife + Filter with Auto Drain + Regulator with Gauge
12048X	48" Gold Anodized Alum. X-Stream™ Air Blade™ Air Knife + Filter with Auto Drain + Regulator with Gauge
12054X	54" Gold Anodized Alum. X-Stream™ Air Blade™ Air Knife + Filter with Auto Drain + Regulator with Gauge

**Extra Stainless Steel Shims X-Stream™ Air Blade™ Air Knives (.002" or .050 mm Thick)**

PART NO.	DESCRIPTION		
		10118XS	18" Stainless Steel Shim
10102XS	2" Stainless Steel Shim	10124XS	24" Stainless Steel Shim
10103XS	3" Stainless Steel Shim	10130XS	30" Stainless Steel Shim
10106XS	6" Stainless Steel Shim	10136XS	36" Stainless Steel Shim
10109XS	9" Stainless Steel Shim	10142XS	42" Stainless Steel Shim
10112XS	12" Stainless Steel Shim	10148XS	48" Stainless Steel Shim
10115XS	15" Stainless Steel Shim	10154XS	54" Stainless Steel Shim

**10900X:** Aluminum X-Stream™ Air Blade™ Air Knife Coupling Kit c/w 10 screws to couple together any aluminum Silent X-Stream™ Air Blade™ Air Knife from 6" & up.

**NOTE:** Plastic shims can wear out quickly in Air Knives if the air is not clean. Nex Flow™ uses ONLY stainless steel shims.

**E-mail:-** ■ sales@nexflow.com ■ sales@nexflowair.com ■ sales@nex-flow.com

**Web:-** ■ www.nexflow.com ■ www.nexflowair.com ■ www.nex-flow.com

**AIR BLADE™ AIR KNIFE**



## Hard Anodized Aluminum X-Stream™ Full-Flow Air Blade™ Air Knives

PART NO.	DESCRIPTION
10002XHA	2" Hard Anodized Alum. X-Stream™ Air Blade™ Air Knife Only
10003XHA	3" Hard Anodized Alum. X-Stream™ Air Blade™ Air Knife Only
10006XHA	6" Hard Anodized Alum. X-Stream™ Air Blade™ Air Knife Only
10009XHA	9" Hard Anodized Alum. X-Stream™ Air Blade™ Air Knife Only
10012XHA	12" Hard Anodized Alum. X-Stream™ Air Blade™ Air Knife Only
10015XHA	15" Hard Anodized Alum. X-Stream™ Air Blade™ Air Knife Only
10018XHA	18" Hard Anodized Alum. X-Stream™ Air Blade™ Air Knife Only
10024XHA	24" Hard Anodized Alum. X-Stream™ Air Blade™ Air Knife Only
10030XHA	30" Hard Anodized Alum. X-Stream™ Air Blade™ Air Knife Only
10036XHA	36" Hard Anodized Alum. X-Stream™ Air Blade™ Air Knife Only
10042XHA	42" Hard Anodized Alum. X-Stream™ Air Blade™ Air Knife Only
10048XHA	48" Hard Anodized Alum. X-Stream™ Air Blade™ Air Knife Only
10054XHA	54" Hard Anodized Alum. X-Stream™ Air Blade™ Air Knife Only
11002XHA	2" Hard Anodized Alum. X-Stream™ Air Blade™ Air Knife plus Filter with Auto Drain
11003XHA	3" Hard Anodized Alum. X-Stream™ Air Blade™ Air Knife plus Filter with Auto Drain
11006XHA	6" Hard Anodized Alum. X-Stream™ Air Blade™ Air Knife plus Filter with Auto Drain
11009XHA	9" Hard Anodized Alum. X-Stream™ Air Blade™ Air Knife plus Filter with Auto Drain
11012XHA	12" Hard Anodized Alum. X-Stream™ Air Blade™ Air Knife plus Filter with Auto Drain
11015XHA	15" Hard Anodized Alum. X-Stream™ Air Blade™ Air Knife plus Filter with Auto Drain
11018XHA	18" Hard Anodized Alum. X-Stream™ Air Blade™ Air Knife plus Filter with Auto Drain
11024XHA	24" Hard Anodized Alum. X-Stream™ Air Blade™ Air Knife plus Filter with Auto Drain
11030XHA	30" Hard Anodized Alum. X-Stream™ Air Blade™ Air Knife plus Filter with Auto Drain
11036XHA	36" Hard Anodized Alum. X-Stream™ Air Blade™ Air Knife plus Filter with Auto Drain
11042XHA	42" Hard Anodized Alum. X-Stream™ Air Blade™ Air Knife plus Filter with Auto Drain
11048XHA	48" Hard Anodized Alum. X-Stream™ Air Blade™ Air Knife plus Filter with Auto Drain
11054XHA	54" Hard Anodized Alum. X-Stream™ Air Blade™ Air Knife plus Filter with Auto Drain
12002XHA	2" Hard Anodized Alum. X-Stream™ Air Blade™ Air Knife + Filter with Auto Drain + Regulator with Gauge
12003XHA	3" Hard Anodized Alum. X-Stream™ Air Blade™ Air Knife + Filter with Auto Drain + Regulator with Gauge
12006XHA	6" Hard Anodized Alum. X-Stream™ Air Blade™ Air Knife + Filter with Auto Drain + Regulator with Gauge
12009XHA	9" Hard Anodized Alum. X-Stream™ Air Blade™ Air Knife + Filter with Auto Drain + Regulator with Gauge
12012XHA	12" Hard Anodized Alum. X-Stream™ Air Blade™ Air Knife + Filter with Auto Drain + Regulator with Gauge
12015XHA	15" Hard Anodized Alum. X-Stream™ Air Blade™ Air Knife + Filter with Auto Drain + Regulator with Gauge
12018XHA	18" Hard Anodized Alum. X-Stream™ Air Blade™ Air Knife + Filter with Auto Drain + Regulator with Gauge
12024XHA	24" Hard Anodized Alum. X-Stream™ Air Blade™ Air Knife + Filter with Auto Drain + Regulator with Gauge
12030XHA	30" Hard Anodized Alum. X-Stream™ Air Blade™ Air Knife + Filter with Auto Drain + Regulator with Gauge
12036XHA	36" Hard Anodized Alum. X-Stream™ Air Blade™ Air Knife + Filter with Auto Drain + Regulator with Gauge
12042XHA	42" Hard Anodized Alum. X-Stream™ Air Blade™ Air Knife + Filter with Auto Drain + Regulator with Gauge
12048XHA	48" Hard Anodized Alum. X-Stream™ Air Blade™ Air Knife + Filter with Auto Drain + Regulator with Gauge
10054XHA	54" Hard Anodized Alum. X-Stream™ Air Blade™ Air Knife + Filter with Auto Drain + Regulator with Gauge

## Extra Stainless Steel Shims X-Stream™ Air Blade™ Air Knives (.002" or .050 mm Thick)

PART NO.	DESCRIPTION		
		10118XS	18" Stainless Steel Shim
10102XS	2" Stainless Steel Shim	10124XS	24" Stainless Steel Shim
10103XS	3" Stainless Steel Shim	10130XS	30" Stainless Steel Shim
10106XS	6" Stainless Steel Shim	10136XS	36" Stainless Steel Shim
10109XS	9" Stainless Steel Shim	10142XS	42" Stainless Steel Shim
10112XS	12" Stainless Steel Shim	10148XS	48" Stainless Steel Shim
10115XS	15" Stainless Steel Shim	10154XS	54" Stainless Steel Shim

**10900XHA:** Aluminum X-Stream™ Air Blade™ Air Knife Coupling Kit c/w 10 screws to couple together any aluminum Silent X-Stream™ Air Blade™ Air Knife from 6" & up.

**NOTE:** Plastic shims can wear out quickly in Air Knives if the air is not clean. Nex Flow™ uses ONLY stainless steel shims.



## STAINLESS STEEL X-STREAM™ AIR BLADE™ AIR KNIVES

PART NO.	DESCRIPTION
10002XS	2" Stainless Steel X-Stream™ Full-Flow Air Blade™ Air Knife Only
10003XS	3" Stainless Steel X-Stream™ Full-Flow Air Blade™ Air Knife Only
10006XS	6" Stainless Steel X-Stream™ Full-Flow Air Blade™ Air Knife Only
10009XS	9" Stainless Steel X-Stream™ Full-Flow Air Blade™ Air Knife Only
10012XS	12" Stainless Steel X-Stream™ Full-Flow Air Blade™ Air Knife Only
10015XS	15" Stainless Steel X-Stream™ Full-Flow Air Blade™ Air Knife Only
10018XS	18" Stainless Steel X-Stream™ Full-Flow Air Blade™ Air Knife Only
10024XS	24" Stainless Steel X-Stream™ Full-Flow Air Blade™ Air Knife Only
10030XS	30" Stainless Steel X-Stream™ Full-Flow Air Blade™ Air Knife Only
10036XS	36" Stainless Steel X-Stream™ Full-Flow Air Blade™ Air Knife Only
10042XS	42" Stainless Steel X-Stream™ Full-Flow Air Blade™ Air Knife Only
10048XS	48" Stainless Steel X-Stream™ Full-Flow Air Blade™ Air Knife Only
10054XS	54" Stainless Steel X-Stream™ Full-Flow Air Blade™ Air Knife Only
11002XS	2" Stainless Steel X-Stream™ Full-Flow Air Blade™ Air Knife plus Filter with Auto Drain
11003XS	3" Stainless Steel X-Stream™ Full-Flow Air Blade™ Air Knife plus Filter with Auto Drain
11006XS	6" Stainless Steel X-Stream™ Full-Flow Air Blade™ Air Knife plus Filter with Auto Drain
11009XS	9" Stainless Steel X-Stream™ Full-Flow Air Blade™ Air Knife plus Filter with Auto Drain
11012XS	12" Stainless Steel X-Stream™ Full-Flow Air Blade™ Air Knife plus Filter with Auto Drain
11015XS	15" Stainless Steel X-Stream™ Full-Flow Air Blade™ Air Knife plus Filter with Auto Drain
11018XS	18" Stainless Steel X-Stream™ Full-Flow Air Blade™ Air Knife plus Filter with Auto Drain
11024XS	24" Stainless Steel X-Stream™ Full-Flow Air Blade™ Air Knife plus Filter with Auto Drain
11030XS	30" Stainless Steel X-Stream™ Full-Flow Air Blade™ Air Knife plus Filter with Auto Drain
11036XS	36" Stainless Steel X-Stream™ Full-Flow Air Blade™ Air Knife plus Filter with Auto Drain
11042XS	42" Stainless Steel X-Stream™ Full-Flow Air Blade™ Air Knife plus Filter with Auto Drain
11048XS	48" Stainless Steel X-Stream™ Full-Flow Air Blade™ Air Knife plus Filter with Auto Drain
11054XS	54" Stainless Steel X-Stream™ Full-Flow Air Blade™ Air Knife plus Filter with Auto Drain
12002XS	2" Stainless Steel X-Stream™ Full-Flow Air Blade™ Air Knife + Filter with Auto Drain + Regulator with Gauge
12003XS	3" Stainless Steel X-Stream™ Full-Flow Air Blade™ Air Knife + Filter with Auto Drain + Regulator with Gauge
12006XS	6" Stainless Steel X-Stream™ Full-Flow Air Blade™ Air Knife + Filter with Auto Drain + Regulator with Gauge
12009XS	9" Stainless Steel X-Stream™ Full-Flow Air Blade™ Air Knife + Filter with Auto Drain + Regulator with Gauge
12012XS	12" Stainless Steel X-Stream™ Full-Flow Air Blade™ Air Knife + Filter with Auto Drain + Regulator with Gauge
12015XS	15" Stainless Steel X-Stream™ Full-Flow Air Blade™ Air Knife + Filter with Auto Drain + Regulator with Gauge
12018XS	18" Stainless Steel X-Stream™ Full-Flow Air Blade™ Air Knife + Filter with Auto Drain + Regulator with Gauge
12024XS	24" Stainless Steel X-Stream™ Full-Flow Air Blade™ Air Knife + Filter with Auto Drain + Regulator with Gauge
12030XS	30" Stainless Steel X-Stream™ Full-Flow Air Blade™ Air Knife + Filter with Auto Drain + Regulator with Gauge
12036XS	36" Stainless Steel X-Stream™ Full-Flow Air Blade™ Air Knife + Filter with Auto Drain + Regulator with Gauge
12042XS	42" Stainless Steel X-Stream™ Full-Flow Air Blade™ Air Knife + Filter with Auto Drain + Regulator with Gauge
12048XS	48" Stainless Steel X-Stream™ Full-Flow Air Blade™ Air Knife + Filter with Auto Drain + Regulator with Gauge
12054XS	54" Stainless Steel X-Stream™ Full-Flow Air Blade™ Air Knife + Filter with Auto Drain + Regulator with Gauge

### Extra Stainless Steel Shims X-Stream™ Air Blade™ Air Knives (.002" or .050 mm Thick)

PART NO.	DESCRIPTION		
		10118XS	18" Stainless Steel Shim
10102XS	2" Stainless Steel Shim	10124XS	24" Stainless Steel Shim
10103XS	3" Stainless Steel Shim	10130XS	30" Stainless Steel Shim
10106XS	6" Stainless Steel Shim	10136XS	36" Stainless Steel Shim
10109XS	9" Stainless Steel Shim	10142XS	42" Stainless Steel Shim
10112XS	12" Stainless Steel Shim	10148XS	48" Stainless Steel Shim
10115XS	15" Stainless Steel Shim	10154XS	54" Stainless Steel Shim

**10900X:** Stainless Steel X-Stream™ Air Blade™ Air Knife Coupling Kit c/w 10 screws to couple together any Stainless Steel Silent X-Stream™ Air Blade™ Air Knife from 6" & up.

**NOTE:** Plastic shims can wear out quickly in Air Knives if the air is not clean. Nex Flow™ uses ONLY stainless steel shims.

**E-mail:-** ■ sales@nexflow.com ■ sales@nexflowair.com ■ sales@nex-flow.com

**Web:-** ■ www.nexflow.com ■ www.nexflowair.com ■ www.nex-flow.com

AIR BLADE™ AIR KNIFE

## STANDARD AIR BLADE™ AIR KNIFE

Blowoff, clean, cool and dry with a strong curtain of amplified airflow.

### WHAT ARE THEY - REASONS TO USE

Standard Air Blade™ Air Knife Blowoff System from Nex Flow™ is easy to mount and maintain, reducing both compressed air consumption and noise levels.

The Standard Air Blade™ Air Knife Blowoff System produces a "Laminar" flow of air along its length using the "Coanda" effect which "entrains" a large volume of air from the surrounding area along with the small amount of compressed air from the Air Blade™ Air knife to produce an output flow up to 30 times. System payback on compressed air savings can be as soon as a few weeks in some applications. It is less costly than the highly efficient and quiet Silent Air Blade™ Air Knife but it is popular for more heavy duty installations due to its greater bulk. In addition, it is excellent for some applications when mounted flush to a flat surface to create an extended air barrier along that surface. Normally the X-Stream™ version is most efficient although the Standard would be lowest initial cost.



A Model 10018 Standard Air Blade™ Air Knife is used to blow scrap pieces and dirt from cellular phone parts after machining.

### STANDARD AIR BLADE™ AIR KNIFE FEATURES:

- ▶ No moving parts - anodized aluminum or stainless steel
- ▶ Compact design, simple, lightweight and portable
- ▶ Rugged design
- ▶ Full flow - air across entire length of Air Knife
- ▶ Air inlets at ends and back
- ▶ Driven by air not electricity
- ▶ Replaces drilled pipe and open jets or nozzles used for blowoff, cleaning, drying and cooling
- ▶ High airflow amplification
- ▶ Instant on-off, no electricity or explosion hazard

### STANDARD AIR BLADE™ AIR KNIFE BENEFITS:

- ▶ Longer life in difficult environments than competitive models
- ▶ Lower compressed air consumption than drilled pipe or rows of open jets and nozzles.
- ▶ Can be placed end to end for continuous airflow.
- ▶ Maintenance free with output easily controlled, safe to use.

**NOTE:** Plastic shims can wear out quickly in Air Knives if the air is not clean. Nex Flow™ uses only stainless steel shims.



Mounting and holding systems are available for the Standard Air Blade Air Knife. Fully flexible positioning  
**See Accessories**

### STANDARD AIR BLADE™ AIR KNIFE - HOW IT WORKS:

**Standard Air Blade™ Air Knife** - Compressed air enters the Air Knife at the rear (or end) ports at (A). Air is entrained at point (B) by the compressed air stream that leaves the Air Knife from a small gap. The entrained air follows the "Coanda" profile along the front face (C) that directs the air flow in a perfect straight line at 90 degrees to create a uniform sheet of air along the entire length of the Air Blade™ Air Knife. As the air leaves the Air Knife at point (D) the amplified air stream maximizes velocity and force is maximized as a well-defined sheet of laminar flow with minimal wind shear for reduced energy use in blowoff and cooling.

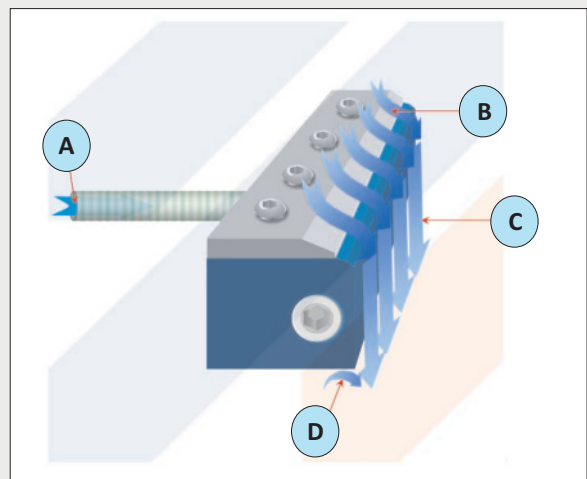

Standard Air Blade™ Air Knife is available in eight standard lengths in anodized aluminum and in seven lengths in stainless steel: 3" (76 mm), 6" (150 mm), 8" (203.2 mm) (not available in stainless), 12" (300 mm), 18" (457 mm), 24" (609.5 mm), 30" (761 mm), 36" (914 mm)

PART NO. (Aluminum & Stainless Steel)	AA Inches (mm)	A Inches (mm)	B Inches (mm)	C Inches (mm)	D Inches (mm)	E Inches (mm)	F Inches (mm)	G Inches (mm)	H Inches (mm)	Number of Rear Inlet (Side Inlets)
Model 10003 Aluminum	3"(76.2)	.625"(15.9)	N/A	N/A	2.375"(60.3)	0.344"(8.7)	1.50"(38.1)	N/A	N/A	1(2)
Model 10003S Stainless	3"(76.2)	.625"(15.9)	N/A	N/A	2.375"(60.3)	0.344"(8.7)	1.50"(38.1)	N/A	N/A	1(2)
Model 10006 Aluminum	6"(152)	1"(25.4)	N/A	N/A	5.0"(12.7)	0.344"(8.7)	3.0"(76.2)	N/A	N/A	1(2)
Model 10006S Stainless	6"(152)	1"(25.4)	N/A	N/A	5.0"(127)	0.344"(8.7)	3.0"(76.2)	N/A	N/A	1(2)
Model 10008 Aluminum	8"(203.2)	1.187"(30)	2.37"(60.2)	5.63"(143)	6.813"(162)	0.344"(8.7)	4.0"(101.6)	N/A	N/A	1(2)
Model 10008S Stainless	8"(203.2)	1.187"(30)	2.37"(60.2)	5.63"(143)	6.813"(162)	0.344"(8.7)	4.0"(101.6)	N/A	N/A	1(2)
Model 10012 Aluminum	12"(305)	1"(25.4)	3.1"(78.7)	8.9"(127)	11.0"(279)	0.344"(8.7)	6.0"(152)	N/S	N/S	1(2)
Model 10012S Stainless	12"(305)	1"(25.4)	3.1"(78.7)	8.9"(127)	11.0"(279)	0.344"(8.7)	6.0"(152)	N/A	N/A	1(2)
Model 10018 Aluminum	18"(457)	1.3"(33.4)	5.8"(148)	12.2"(310)	16.7"(424)	0.344"(8.7)	4.25"(108)	13.75"(349)	N/A	2(2)
Model 10018S Stainless	18"(457)	1.3"(33.4)	5.8"(148)	12.2"(310)	16.7"(424)	0.344"(8.7)	4.25"(108)	13.75"(349)	N/A	2(2)
Model 10024 Aluminum	24"(610)	1.3"(33.4)	4.2"(107)	19.8"(503)	22.7"(577)	0.344"(8.7)	7.3"(183)	16.7"(424)	12.0"(304.8)	2(2)
Model 10024S Stainless	24"(610)	1.3"(33.4)	4.2"(107)	19.8"(503)	22.7"(577)	0.344"(8.7)	7.3"(183)	16.7"(424)	12.0"(304.8)	2(2)
Model 10030 Aluminum	30"(761)	1.13"(28.7)	10.92"(277)	19.08"(485)	28.87"(733)	0.344"(8.7)	7.66"(195)	22.34"(567)	N/A	2(2)
Model 10030S Stainless	30"(761)	1.13"(28.7)	10.92"(277)	19.08"(485)	28.87"(733)	0.344"(8.7)	7.66"(195)	22.34"(567)	N/A	2(2)
Model 10036 Aluminum	36"(914)	1.09"(27.7)	10.75"(273)	18.75"(28.4)	34.92"(887)	0.344"(8.7)	7.53"(191)	28.47"(723)	18.8"(478)	2(2)
Model 10036S Stainless	36"(914)	1.09"(27.7)	10.75"(273)	18.75"(28.4)	34.92"(997)	0.344"(8.7)	7.53"(191)	28.47"(723)	18.8"(478)	2(2)

**AIR BLADE™ AIR KNIFE**

**STANDARD AIR BLADE™ AIR KNIFE**

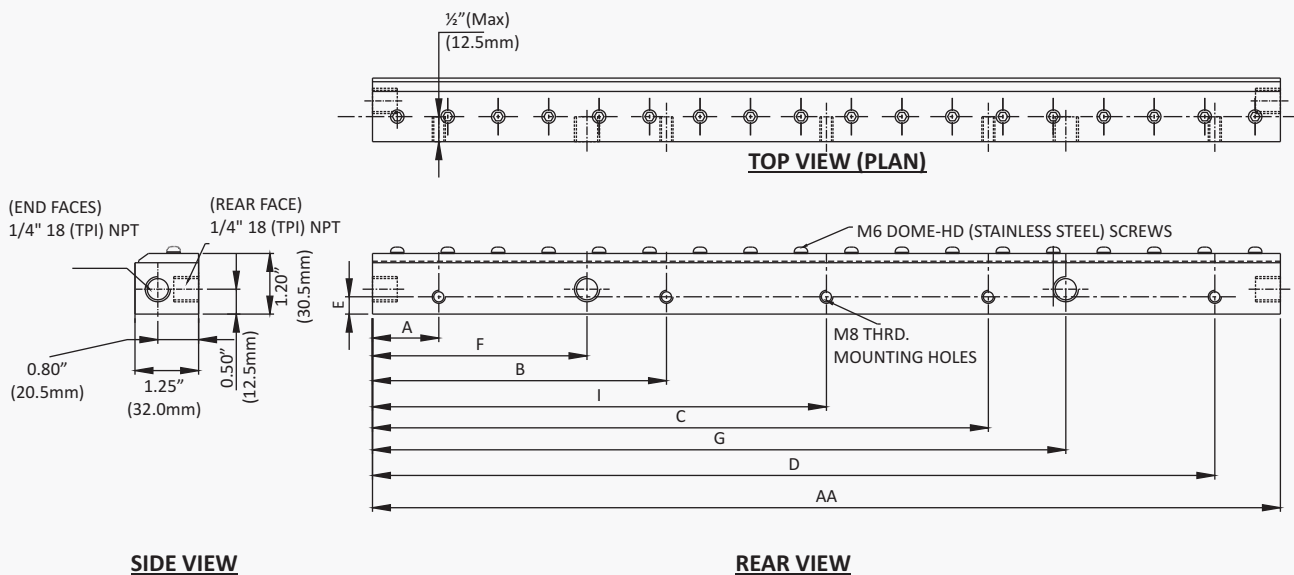

(\* BSP Threads or Adaptors can be supplied depending on country location)

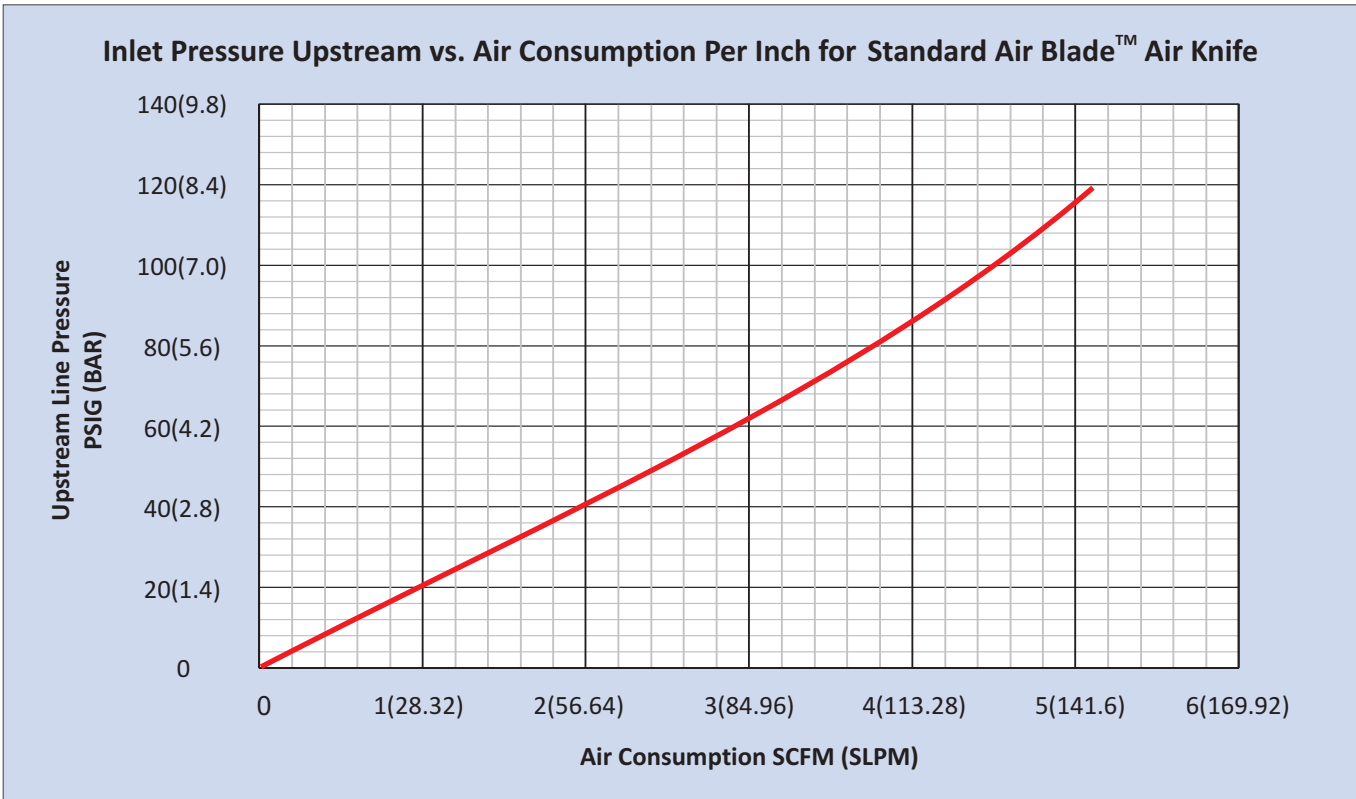

**NOTE:** Tests were performed using a 12" Model 10012 Standard Air Blade™ Air Knife

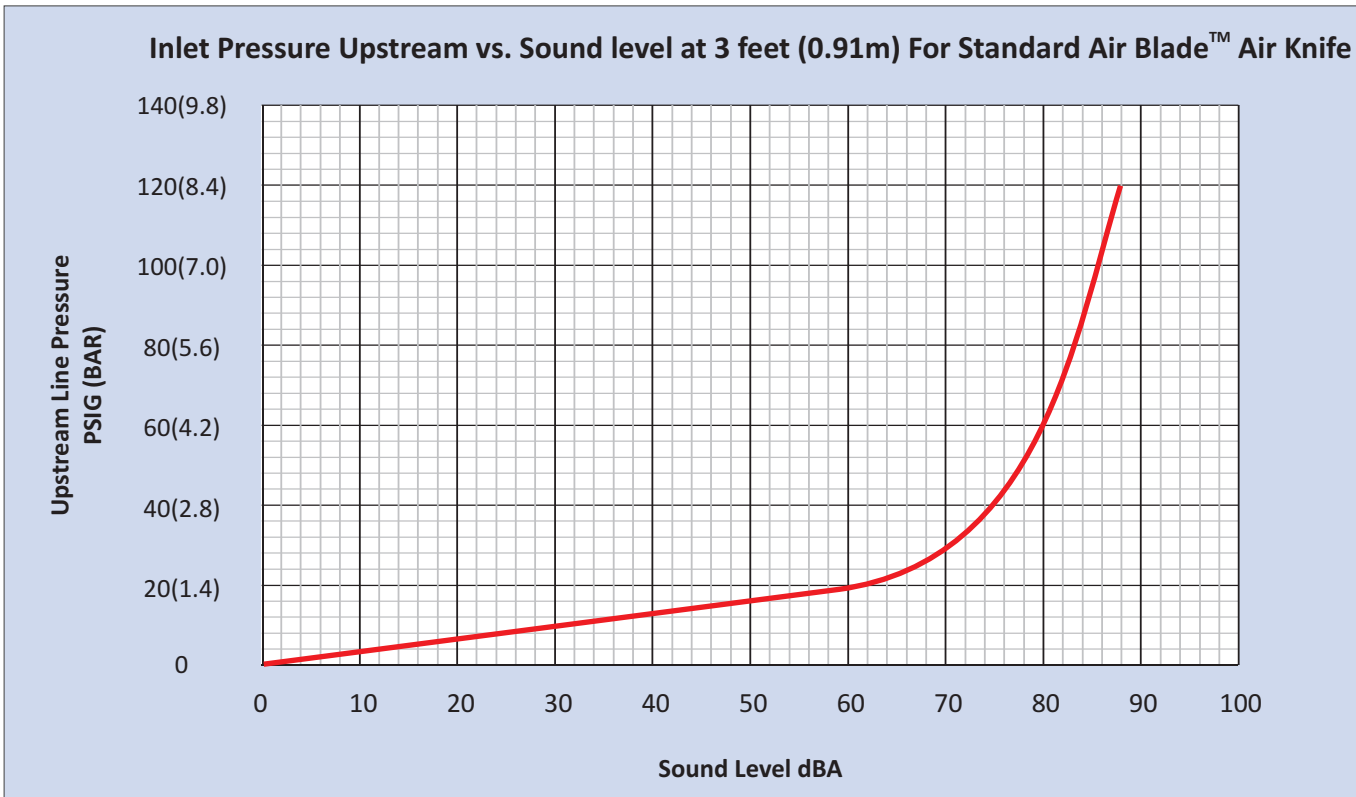

**NOTE:** Tests were performed using a 12" Model 10012 Standard Air Blade™ Air Knife



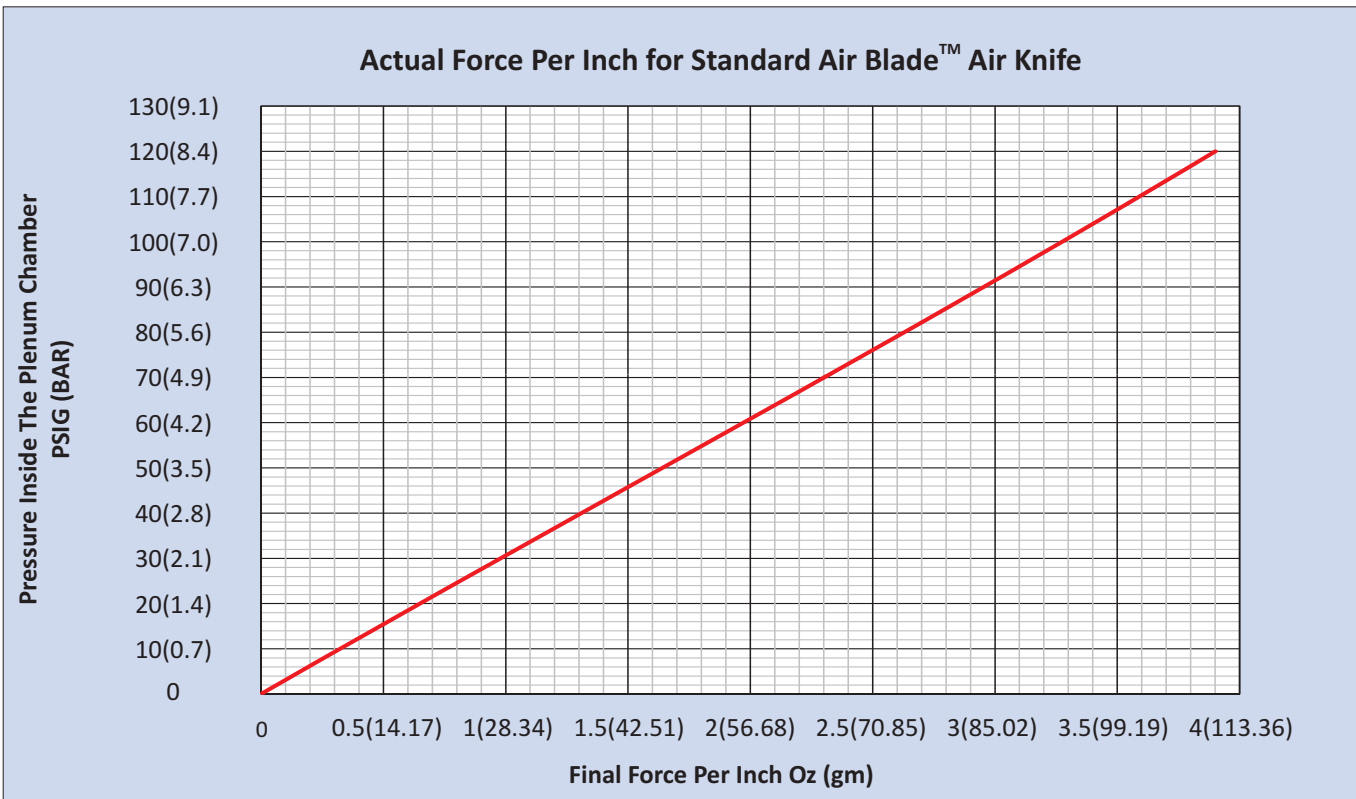

**NOTE:** Force per inch of Air Knife was based on tests done with a 12" Standard Air Blade™ Air Knife with a .002" (.050 mm) gap. Force was measured at a target 6" from the Air Knife.

Actual results may vary due to tolerance variations.  
 Estimate 30% more force with a .004" (.100 mm) gap.

**Force per Inch Explanation** - The pressure is measured at the chamber inside the Standard Air Blade™ Air Knife and not upstream. The force per inch is from tests using a Standard Air Blade™ Air Knife with the graph extrapolated for higher end pressures. Figures will vary with the length of the Air Knife. The longer the air knife, the less the chamber pressure will be and the force per inch will also decrease. This is because of the limited size and volume of the chamber and also because of the limited air inlet holes.

Estimated chamber pressure inside the Standard Air Blade™ Air Knife as a percentage of upstream line pressure can be reasonably estimated as follows. Size of air lines, upstream pressure, and piping configurations can cause a great variation in actual force produced and actual pressure formed in the chamber of the Air Knife. However, for general engineering applications the multiplication factors as shown in the graph "Multiplication Factors to Obtain Plenum Pressure for Standard Air Blade™ Air Knife" can be used to estimate the plenum pressure. Then you can obtain the force per inch from the Actual Force per inch graph.

- ▶ In general, the force per inch will be greater for shorter length Standard Air Blade™ Air Knives.
- ▶ If a particular application requires a greater force, it may be more useful to have several smaller length Air Knives than one larger one.

**EXAMPLE:**

Two (2) 12" Standard Air Blade™ Air Knives with a line pressure of 80 psig can be estimated to have a chamber pressure of 0.9 times the line pressure or  $0.9 \times 80 = 72$  psig.

The force per inch from the Force graph at 72 psig is about 2.2 Oz per inch for a total of  $2.4 \times 24 = 57.6$  Oz force

One (1) 24" Standard Air Blade™ Air Knife with a line pressure of 80 psig can be estimated to have a chamber pressure of 0.70 times the line pressure of  $0.7 \times 80 = 56$  psig.

The force per inch from the Force graph at 56 psig is  $1.8 \times 24 = 43$  Oz force.

**In most applications the single 24" Air Knife will work but in applications where force is critical, it can make sense to use several smaller Air Knives instead.**



**Multiplication Factors to Obtain Plenum Pressure for Standard Air Blade™ Air Knife**

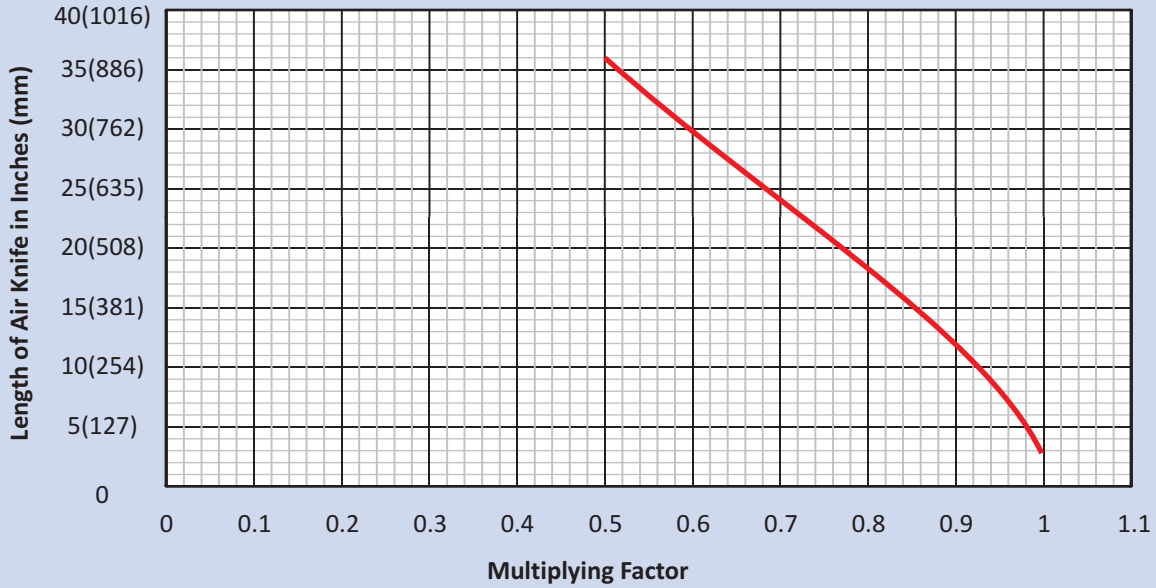

**NOTE:** These multipliers are based on having a large compressed air supply with air lines in the 1" range and with the location of use mid-plant. If the location is near the end of a long airline run, if there is a heavy use load and if air lines are small the multiplier can be reduced as much as 50%

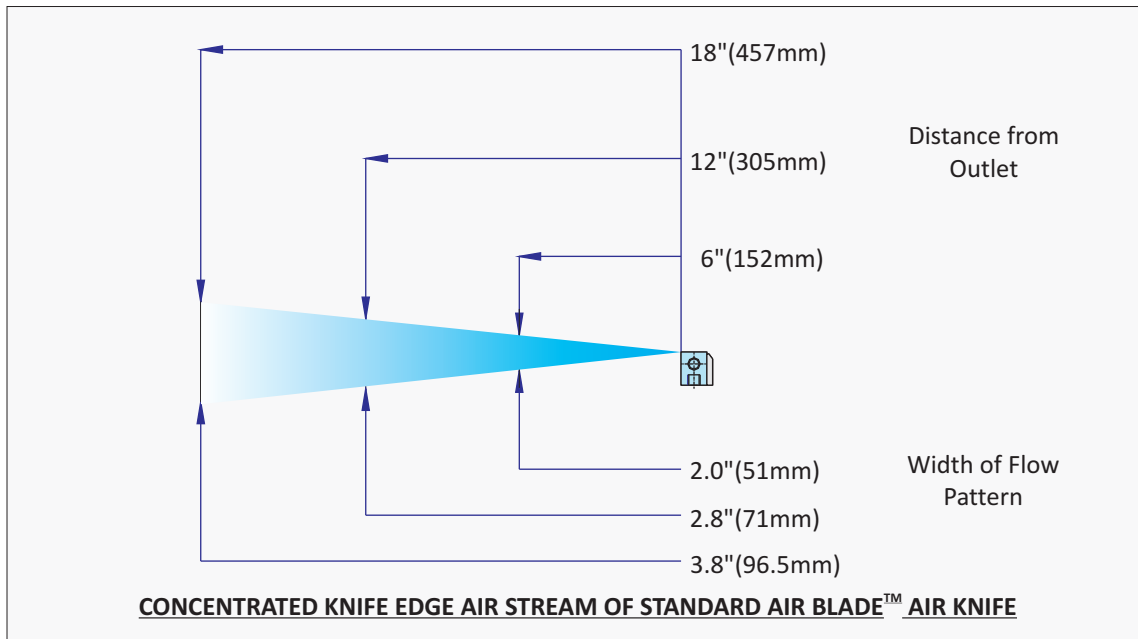

**NOTE:**

The performance of the X-Stream™ Air Blade™ Air Knife and the Standard Air Blade™ Air Knife will be relatively the same given "same" internal chamber conditions. However, due to design the X-Stream™ Air Blade™ will use about 15% "LESS" compressed air. This generally means less air line pressure drop and "higher" chamber pressures in an X-Stream™ Air Blade™ given the same application and therefore superior performance (as well as lower noise levels). The Standard Air Blade™ Air Knife however is lower cost has applications suited to its unique design.



**Force per Inch at Various Distance from Target at 80 PSIG Plenum Pressure for Standard Air Blade™ Air Knife**

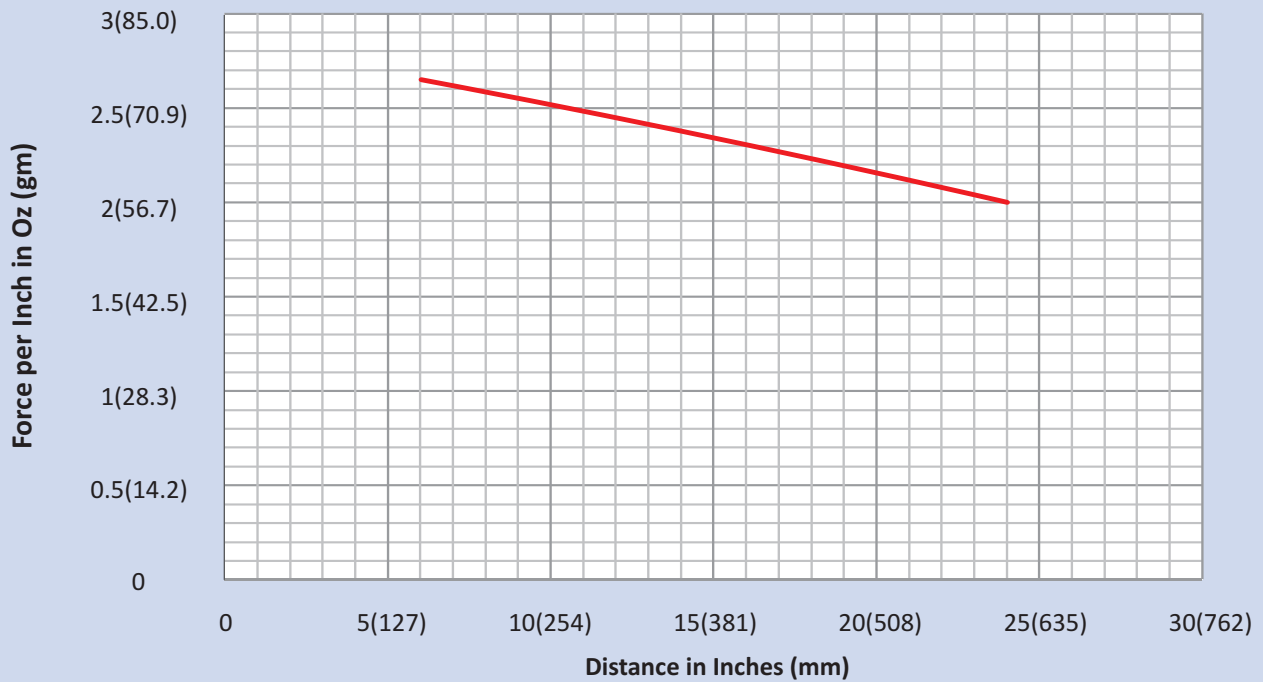

**NOTE:** Tests were performed using a 12" Model 10012 Standard Air Blade™ Air Knife

A Model 10003 3" Standard Air Blade™ Air Knife is mounted such that the surface of the Air Knife is flush with the surface of a camera lens. The air flows along the surface of the Air Knife and continues along the lens due to a boundary layer effect that provides a laminar "barrier" to the dirty environmental air, keeping the lens clean and dry.

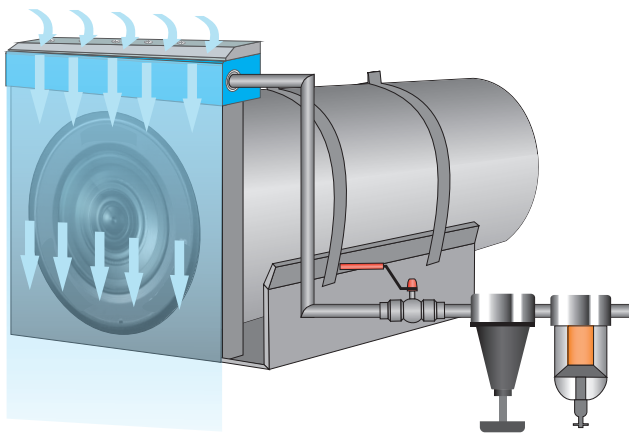

Two Model 10012 Standard Air Blade™ Air Knives are installed on a duct (One on top, One on bottom) to draw in waste fumes & exhaust. The air leaving the Air Knives hug the inside wall creating an excellent vacuum inside the duct.

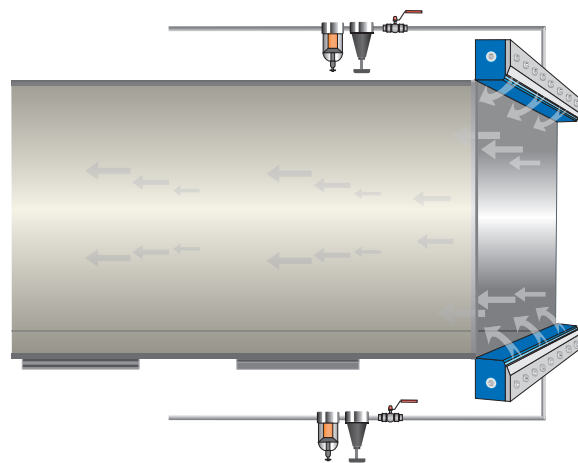

**AIR BLADE™ AIR KNIFE**



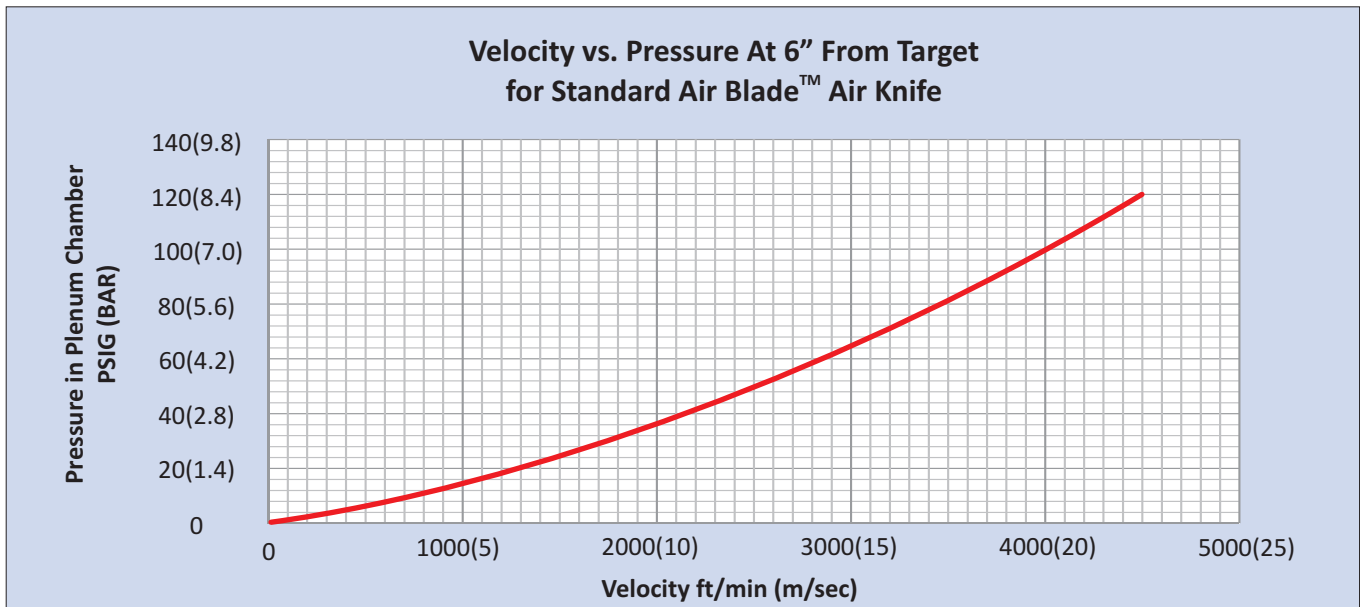

**NOTE:** Tests were performed using a 12" Model 10012 Standard Air Blade™ Air Knife

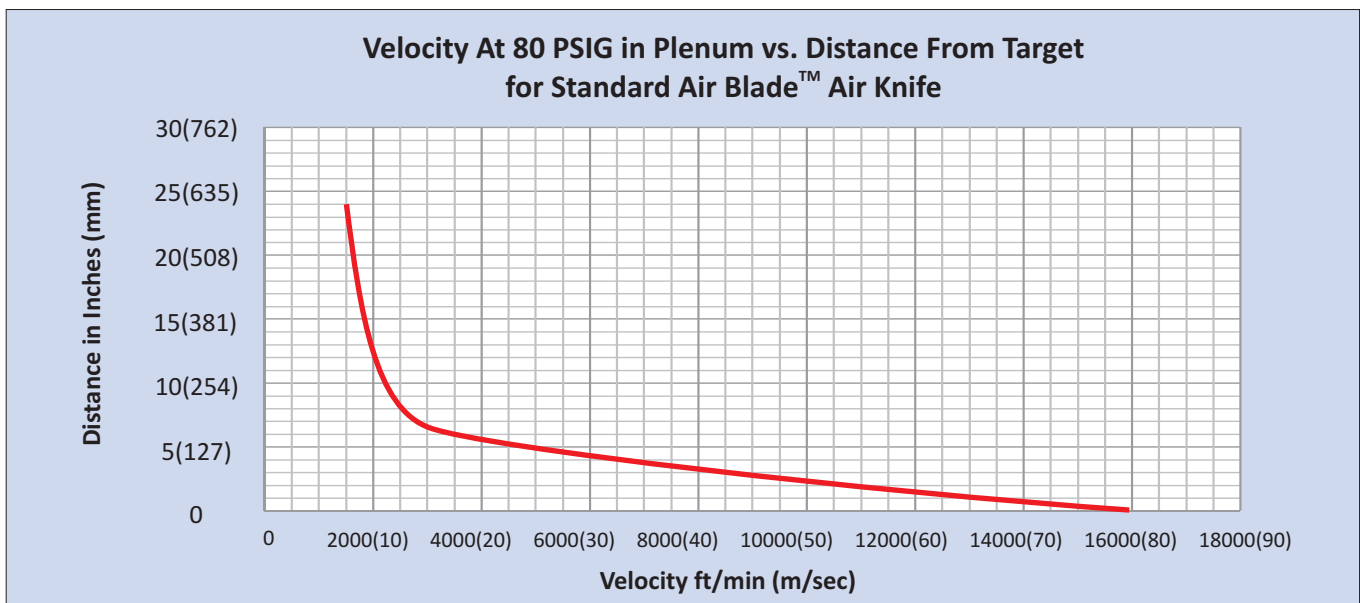

**NOTE:** Tests were performed using a 12" Model 10012 Standard Air Blade™ Air Knife

Velocity is important in that it can determine the cooling effect and to some extent is related to the blowoff force. Velocity will vary significantly depending on the temperature of the ambient air the hotter the air, the greater the velocity (and the greater the amplification of air flow) so velocity figures at best are an approximation. As air is entrained, the flow increases and as the flow increases the velocity must come down.

The velocity at the exit of the Standard Air Blade™ Air Knife is obviously the highest but the figure is of no real value as once the surrounding air is entrained, the velocity drops dramatically. (Be very wary of extremely high velocity claims downstream of any Air Knife). The figures we provide can be verified with a velocity meter. There will be variations in measurement due to air pressure, and atmospheric conditions. The velocity is, among these other things dependent on the chamber pressure. That pressure in turn depends upon pipe size, pressure drops in the system, distance from the compressor station to the use point, and many other factors. (See previous pages referring to force approximations and multipliers to estimate chamber pressure).



**CALCULATING AIR SAVINGS**

The chart below shows the air consumption at different pressures of various hole sizes compare to the air consumption per inch of an Standard Air Blade™ Air Knife. To obtain the air consumption of drilled holes in pipe determine the size of the holes and multiply the air loss by the number of holes over the length.

The air usage of the X-Stream™ Air Blade™ Air Knife is per inch - just multiply the figure from the chart by the length of the Air Blade™ Air Knife.

**EXAMPLE:**

Assume an existing blowoff of a 24" long pipe with 3/32" holes spaced 3/4" inches apart for a total of 32 holes. At 80 PSIG from the graph each hole consumes about 9.4 SCFM for a total of 32 X 9.4 = 300.8 SCFM

At 80 PSIG a 24" Standard™ Air Blade™ Air Knife consumes 24 X 3.8 SCFM/inch = 91.2 SCFM

Compressed air saved is 300.8 - 91.2 = 209.6 SCFM

Using actual air costs if known (or assuming a reasonable cost of \$.30 US per 1000 cubic feet) the dollars saved is 209.6 X 60 X 0.30/1000 = \$3.77/hr or assuming an 2000 hour working year = \$7450.00 SAVED PER YEAR

**Diameter of hole in pipe in Inches (mm) and air consumption per Inch (25.4mm) of Air Knife.**

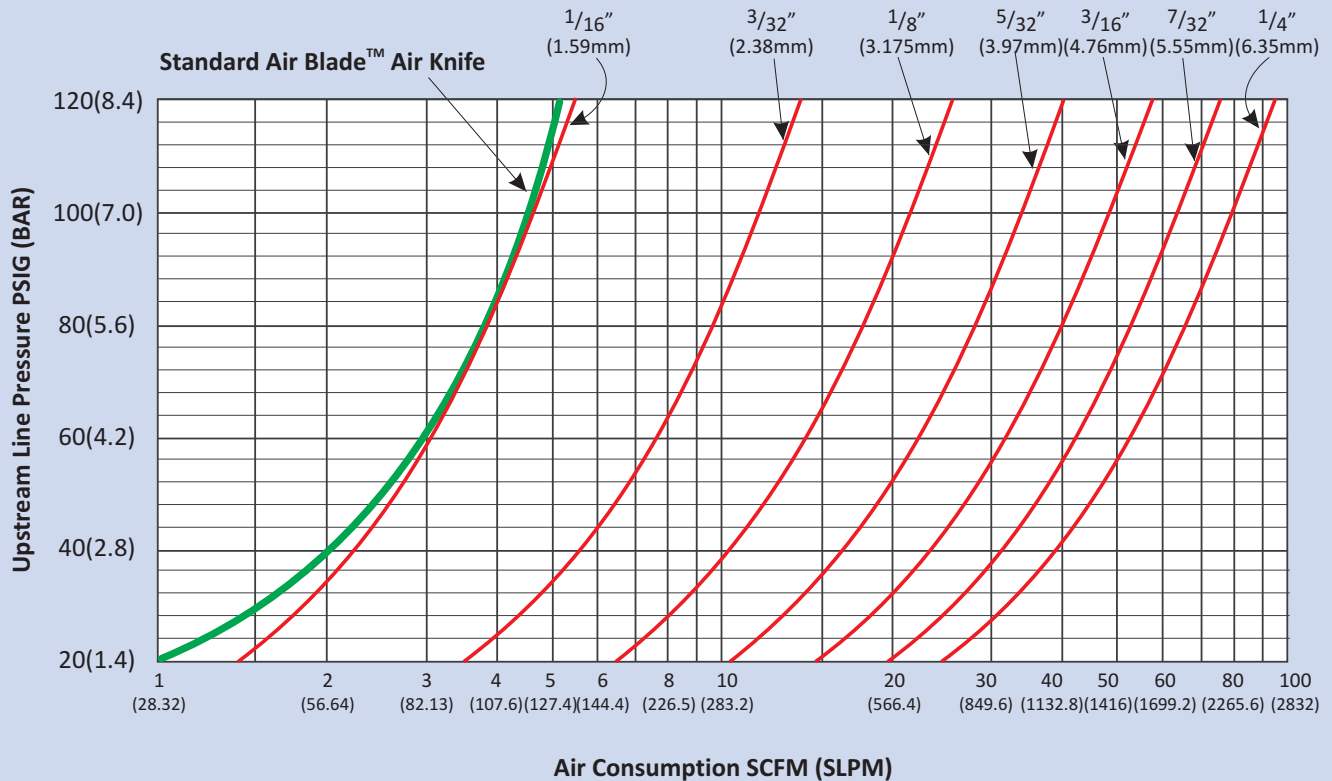

**AIR BLADE™ AIR KNIFE**



**Aluminum Standard Air Blade™ Air Knife**

PART NO.	DESCRIPTION
10003	3" Aluminum Standard Full-Flow Air Blade™ Air Knife Only
10006	6" Aluminum Standard Full-Flow Air Blade™ Air Knife Only
10008	8" Aluminum Standard Full-Flow Air Blade™ Air Knife Only
10012	12" Aluminum Standard Full-Flow Air Blade™ Air Knife Only
10018	18" Aluminum Standard Full-Flow Air Blade™ Air Knife Only
10024	24" Aluminum Standard Full-Flow Air Blade™ Air Knife Only
10030	30" Aluminum Standard Full-Flow Air Blade™ Air Knife Only
10036	36" Aluminum Standard Full-Flow Air Blade™ Air Knife Only
11003	3" Aluminum Standard Full-Flow Air Blade™ Air Knife plus Filter with Auto Drain
11006	6" Aluminum Standard Full-Flow Air Blade™ Air Knife plus Filter with Auto Drain
11008	8" Aluminum Standard Full-Flow Air Blade™ Air Knife plus Filter with Auto Drain
11012	12" Aluminum Standard Full-Flow Air Blade™ Air Knife plus Filter with Auto Drain
11018	18" Aluminum Standard Full-Flow Air Blade™ Air Knife plus Filter with Auto Drain
11024	24" Aluminum Standard Full-Flow Air Blade™ Air Knife plus Filter with Auto Drain
11030	30" Aluminum Standard Full-Flow Air Blade™ Air Knife plus Filter with Auto Drain
11036	36" Aluminum Standard Full-Flow Air Blade™ Air Knife plus Filter with Auto Drain
12003	3" Aluminum Standard Full-Flow Air Blade™ Air Knife + Filter with Auto Drain + Reg. With gauge
12006	6" Aluminum Standard Full-Flow Air Blade™ Air Knife + Filter with Auto Drain + Reg. With gauge
12008	8" Aluminum Standard Full-Flow Air Blade™ Air Knife + Filter with Auto Drain + Reg. with gauge
12012	12" Aluminum Standard Full-Flow Air Blade™ Air Knife + Filter with Auto Drain + Reg. With gauge
12018	18" Aluminum Standard Full-Flow Air Blade™ Air Knife + Filter with Auto Drain + Reg. with gauge
12024	24" Aluminum Standard Full-Flow Air Blade™ Air Knife + Filter with Auto Drain + Reg. with gauge
12030	30" Aluminum Standard Full-Flow Air Blade™ Air Knife + Filter with Auto Drain + Reg. with gauge
12036	36" Aluminum Standard Full-Flow Air Blade™ + Filter with Auto Drain + Regulator with gauge

**Extra Stainless Steel Shims Standard Air Blade™ Air Knife (.002" or .050 mm Thick)**

PART NO.	DESCRIPTION	PART NO.	DESCRIPTION
10103S	3" Stainless Steel Shim	10118S	18" Stainless Steel Shim
10106S	6" Stainless Steel Shim	10124S	24" Stainless Steel Shim
10108S	8" Stainless Steel Shim	10130S	30" Stainless Steel Shim
10112S	12" Stainless Steel Shim	10136S	36" Stainless Steel Shim

**NOTE:** Plastic shims can wear out quickly in Air Knives if the air is not clean. Nex Flow™ uses ONLY stainless steel shims.



**Stainless Steel Standard Air Blade™ Air Knife**

PART NO.	DESCRIPTION
10003S	3" Stainless Steel Standard Full-Flow Air Blade™ Only
10006S	6" Stainless Steel Standard Full-Flow Air Blade™ Only
10012S	12" Stainless Steel Standard Full-Flow Air Blade™ Only
10018S	18" Stainless Steel Standard Full-Flow Air Blade™ Only
10024S	24" Stainless Steel Standard Full-Flow Air Blade™ Only
10030S	30" Stainless Steel Standard Full-Flow Air Blade™ Only
10036S	36" Stainless Steel Standard Full-Flow Air Blade™ Only
11003S	3" Stainless Steel Standard Full-Flow Air Blade™ plus Filter with Auto Drain
11006S	6" Stainless Steel Standard Full-Flow Air Blade™ plus Filter with Auto Drain
11012S	12" Stainless Steel Standard Full-Flow Air Blade™ plus Filter with Auto Drain
11018S	18" Stainless Steel Standard Full-Flow Air Blade™ plus Filter with Auto Drain
11024S	24" Stainless Steel Standard Full-Flow Air Blade™ plus Filter with Auto Drain
11030S	30" Stainless Steel Standard Full-Flow Air Blade™ plus Filter with Auto Drain
11036S	36" Stainless Steel Standard Full-Flow Air Blade™ plus Filter with Auto Drain
12003S	3" Stainless Steel Standard Full-Flow Air Blade™ + Filter with Auto Drain + Regulator with gauge
12006S	6" Stainless Steel Standard Full-Flow Air Blade™ + Filter with Auto Drain + Regulator
12012S	12" Stainless Steel Standard Full-Flow Air Blade™ + Filter with Auto Drain + Regulator with gauge
12018S	18" Stainless Steel Standard Full-Flow Air Blade™ + Filter with Auto Drain + Regulator with gauge
12024S	24" Stainless Steel Standard Full-Flow Air Blade™ + Filter with Auto Drain + Regulator with gauge
12030S	30" Stainless Steel Standard Full-Flow Air Blade™ + Filter with Auto Drain + Regulator with gauge
12036S	36" Stainless Steel Standard Full-Flow Air Blade™ + Filter with Auto Drain + Regulator with gauge

**Extra Stainless Steel Shims for Standard Air Blade™ Air Knife (.002" or .050 mm Thick)**

PART NO.	DESCRIPTION
10103S	3" Stainless Steel Shim
10106S	6" Stainless Steel Shim
10112S	12" Stainless Steel Shim
10118S	18" Stainless Steel Shim

PART NO.	DESCRIPTION
10124S	24" Stainless Steel Shim
10130S	30" Stainless Steel Shim
10136S	36" Stainless Steel Shim

**NOTE:** Plastic shims can wear out quickly in Air Knives if the air is not clean. Nex Flow™ uses ONLY stainless steel shims.

## RING BLADE™ AIR WIPE

**Blowoff, clean, cool and dry cable, pipe, extrusions, hose, wire and rope. Split design requires zero threading. Uniform 360 degree variable flow and force for temperatures up to 800°F (427°C)**

### WHAT ARE THEY - REASONS TO USE

**Air Wipe Blowoff System** - Ring Blade™ from Nex Flow™ is easy to mount and maintain, and reduces both compressed air consumption and noise levels.

It produces a "laminar" flow of air along its 360° angle using the "Coanda" effect which "entrains" a large volume of air from the surrounding area along with the small amount of compressed air from the Ring Blade™ air-saver wiper-blade to produce an output flow up to 30 times.

The Ring Blade™ air wipe blowoff system payback on compressed air savings can be as short as a few weeks when compared to nozzle "rings" or simple annular slots used by other air wiping systems. Blowoff, cool, and clean products such as cable, pipe, wire and hose.

### RING BLADE™ AIR WIPE BLOWOFF SYSTEM BENEFITS:

- ▶ Longer life in difficult environments for aluminum models because of anodizing, 316L stainless models for high temperate and corrosive environments.
- ▶ Easy to install and maintain and allows removal of a continuous piece.
- ▶ Even blowoff around the part, light in weight and compact.
- ▶ Lower compressed air consumption than a ring of drilled pipe or ring of open jets and nozzles.
- ▶ Maintenance free with output easily controlled, safe to use.

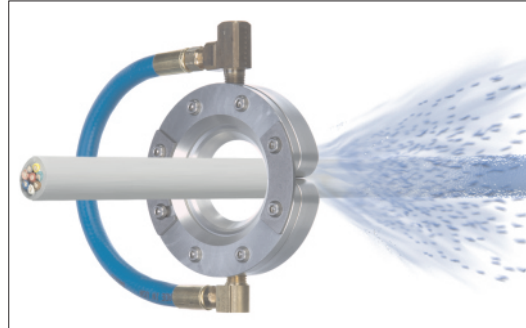

### RING BLADE™ AIR WIPE BLOWOFF SYSTEM FEATURES:

- ▶ No moving parts - anodized aluminum or 316L stainless steel
- ▶ Compact design, simple, lightweight and portable.
- ▶ Full Flow Split Design - air across entire circumference. Designed as two pieces hinged together to open & close around the part. The 2 pieces are connected with a hose to deliver the compressed air using a single connection (except for the 9" and 11" which have four inlet connections or two connections per half).
- ▶ Driven by air not electricity.
- ▶ High airflow amplification.
- ▶ Instant on-off, no electricity or explosion hazard.

### RING BLADE™ AIR WIPE BLOWOFF SYSTEM APPLICATIONS:

- ▶ Blowoff of dust, liquid, contaminants and uniformly wipe surfaces.
- ▶ Dry after washing, plating or coating.
- ▶ Cool hot surfaces.
- ▶ Dry extruded profiles, plastic tubing, hose, wire, fiber optics, ribbon, strips.
- ▶ Prevent solution carryover and avoid cross contamination.
- ▶ Clean paint gun tips.
- ▶ Remove access water, coatings, oil.

### RING BLADE™ AIR WIPE SYSTEM - HOW IT WORKS:

**Ring Blade™ Air Wipe** - Compressed air enters at point (A) into an annular chamber and throttled through a small ring nozzle at high velocity. This air stream clings to the "coanda" profile directing the air stream down toward the surface which is angled to create a "cone" style directed force to best clean, wipe and dry a surface. The surrounding air is entrained at point (B) creating an amplified 360 degree conical airflow at point (C) to uniformly wipe the surface of the of the material running through the Ring Blade™. The wet or dirty material (D) direction of travel is against the flow.

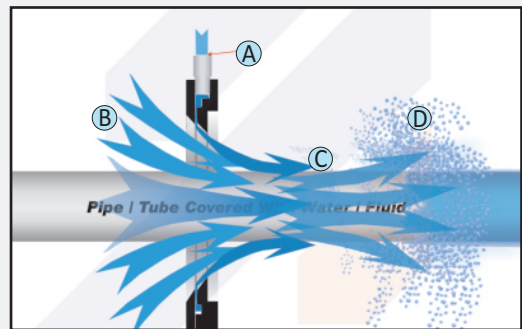

Ring Blade™ Air Wipe™ is available in eight standard sizes in anodized aluminum: ½" (12.7 mm), 1" (25.4 mm), 2" (50.8 mm), 3"(76mm), 4" (102 mm), 5" (127 mm), 6" (152 mm) and 7" (178 mm) (with brass fittings and special rubberized plastic hose for standard applications or with stainless steel hose for moderate temperatures up to 400 F (204 C). The 9" (229 mm) and 11: (279 mm) is available in anodized aluminum. No hose supplied. May be used for standard and moderate temperatures to 400 F (204 C). **Ring Blade™ Air Wipe™** also is available in eight sizes in 316L stainless steel: ½" (12.7 mm), 1" (25.4 mm), 2" (50.8 mm), 3" (76 mm), 4" (102 mm), 5" (127 mm), 6" (152 mm) and 7" (178 mm) with stainless steel fittings and hose for high temperatures up to 800 F (427 C) and for corrosive environments.

STANDARD APPLICATIONS	X-STREAM™ MODERATE TEMP. TO 400°F (204°C)	316L STAINLESS HIGH TEMP. TO 800°F (427°C) and CORROSIVE ENVIRONMENTS	A Inches (mm)	B Inches (mm)	C Inches (mm)	Compressed Air Connection
20000	20000X	20000XS-316L	0.50" (12.7)	3.25" (82.6)	2.63" (66.8)	1/4" NPT
20001	20001X	20001XS-316L	1.00" (25.4)	3.75" (95.3)	3.00" (76.2)	1/4" NPT
20002	20002X	20002XS-316L	2.00" (50.8)	4.75" (121)	4.00" (102.6)	1/4" NPT
20003	20003X	20003XS-316L	3.00" (76.2)	5.75" (146)	5.00" (127)	1/4" NPT
20004	20004X	20004XS-316L	4.00" (102.6)	6.75" (171)	6.00" (153)	1/4" NPT
20005	20005X	20005XS-316L	5.00" (127.0)	7.75" (197)	7.00" (178)	3/8" NPT
20006	20006X	20006XS-316L	6.00" (153)	8.75" (222)	8.00" (203)	3/8" NPT
20007	20007X	20007XS-316L	7.00" (178)	9.75" (248)	9.00" (229)	3/8" NPT
	20009		9.00" (229)	11.75" (298.5)	11.00" (279)	4x1/4" NPT
	20011		11.00" (279)	13.75" (349)	13.00" (330)	4x1/4" NPT

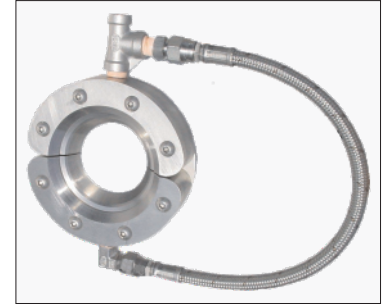

High Temperature 316L Stainless Steel Ring Blade™ c/w all stainless fittings and hose.

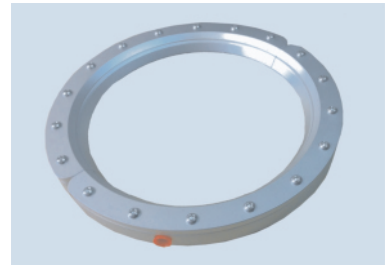

9" and 11" units have two air inlets per side.

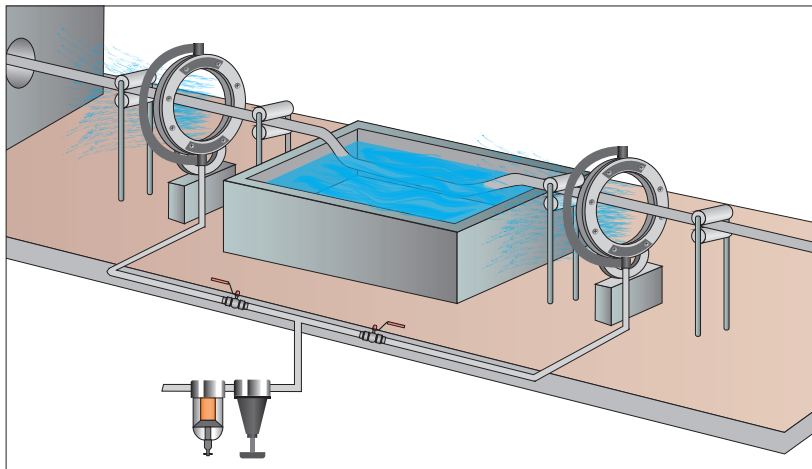

Two Model 20002 - 2" Ring Blade™ Air Wipe system are used to clean and dry extruded automotive trim. The design of the air wipe allows the blowoff force to get into the automotive trim gaps and effectively clean and dry the extruded part. If a bubble occurs in the trim, the Ring Blade™ air wipe can be opened up to pass the bubble without disrupting production.

**RING BLADE™ AIR WIPE SYSTEM**

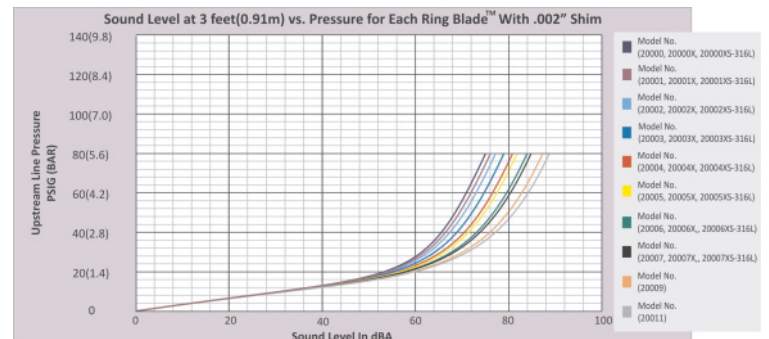
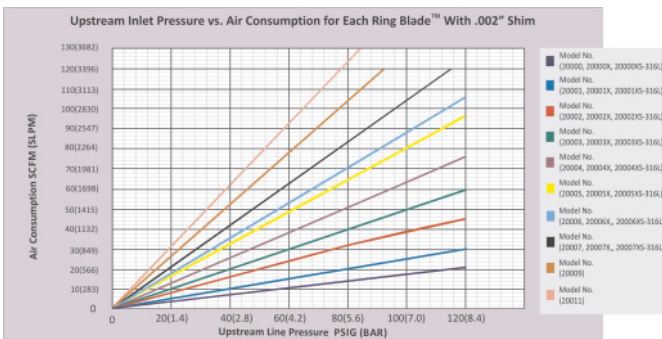

## ALUMINUM RING BLADE™ AIR WIPE SYSTEMS - UP TO 150°F (66°C)

PART NO.	DESCRIPTION
20000	½" Anodized Aluminum Ring Blade™ Air Wipe only
20001	1" Anodized Aluminum Ring Blade™ Air Wipe only
20002	2" Anodized Aluminum Ring Blade™ Air Wipe only
20003	3" Anodized Aluminum Ring Blade™ Air Wipe only
20004	4" Anodized Aluminum Ring Blade™ Air Wipe only
20005	5" Anodized Aluminum Ring Blade™ Air Wipe only
20006	6" Anodized Aluminum Ring Blade™ Air Wipe only
20007	7" Anodized Aluminum Ring Blade™ Air Wipe only
21000	½" Anodized Aluminum Ring Blade™ Air Wipe plus Filter with Auto Drain
21001	1" Anodized Aluminum Ring Blade™ Air Wipe plus Filter with Auto Drain
21002	2" Anodized Aluminum Ring Blade™ Air Wipe plus Filter with Auto Drain
21003	3" Anodized Aluminum Ring Blade™ Air Wipe plus Filter with Auto Drain
21004	4" Anodized Aluminum Ring Blade™ Air Wipe plus Filter with Auto Drain
21005	5" Anodized Aluminum Ring Blade™ Air Wipe plus Filter with Auto Drain
21006	6" Anodized Aluminum Ring Blade™ Air Wipe plus Filter with Auto Drain
21007	7" Anodized Aluminum Ring Blade™ Air Wipe plus Filter with Auto Drain
22000	½" Anodized Aluminum Ring Blade™ Air Wipe plus Filter with Auto Drain & Regulator with Gauge
22001	1" Anodized Aluminum Ring Blade™ Air Wipe plus Filter with Auto Drain & Regulator with Gauge
22002	2" Anodized Aluminum Ring Blade™ Air Wipe plus Filter with Auto Drain & Regulator with Gauge
22003	3" Anodized Aluminum Ring Blade™ Air Wipe plus Filter with Auto Drain & Regulator with Gauge
22004	4" Anodized Aluminum Ring Blade™ Air Wipe plus Filter with Auto Drain & Regulator with Gauge
22005	5" Anodized Aluminum Ring Blade™ Air Wipe plus Filter with Auto Drain & Regulator with Gauge
22006	6" Anodized Aluminum Ring Blade™ Air Wipe plus Filter with Auto Drain & Regulator with Gauge
22007	7" Anodized Aluminum Ring Blade™ Air Wipe plus Filter with Auto Drain & Regulator with Gauge

## ALUMINUM RING BLADE™ AIR WIPE SYSTEMS - UP TO 400°F (204°C)

PART NO.	DESCRIPTION
20000X	½" Medium Temperature Anodized Aluminum Ring Blade™ Air Wipe only
20001X	1" Medium Temperature Anodized Aluminum Ring Blade™ Air Wipe only
20002X	2" Medium Temperature Anodized Aluminum Ring Blade™ Air Wipe only
20003X	3" Medium Temperature Anodized Aluminum Ring Blade™ Air Wipe only
20004X	4" Medium Temperature Anodized Aluminum Ring Blade™ Air Wipe only
20005X	5" Medium Temperature Anodized Aluminum Ring Blade™ Air Wipe only
20006X	6" Medium Temperature Anodized Aluminum Ring Blade™ Air Wipe only
20007X	7" Medium Temperature Anodized Aluminum Ring Blade™ Air Wipe only
21000X	½" Medium Temperature Anodized Aluminum Ring Blade™ Air Wipe plus Filter with Auto Drain
21001X	1" Medium Temperature Anodized Aluminum Ring Blade™ Air Wipe plus Filter with Auto Drain
21002X	2" Medium Temperature Anodized Aluminum Ring Blade™ Air Wipe plus Filter with Auto Drain
21003X	3" Medium Temperature Anodized Aluminum Ring Blade™ Air Wipe plus Filter with Auto Drain
21004X	4" Medium Temperature Anodized Aluminum Ring Blade™ Air Wipe plus Filter with Auto Drain
21005X	5" Medium Temperature Anodized Aluminum Ring Blade™ Air Wipe plus Filter with Auto Drain
21006X	6" Medium Temperature Anodized Aluminum Ring Blade™ Air Wipe plus Filter with Auto Drain
21007X	7" Medium Temperature Anodized Aluminum Ring Blade™ Air Wipe plus Filter with Auto Drain
22000X	½" Medium Temperature Anodized Aluminum Ring Blade™ Air Wipe + Filter with Auto Drain & Reg. with Gauge
22001X	1" Medium Temperature Anodized Aluminum Ring Blade™ Air Wipe + Filter with Auto Drain & Reg. with Gauge
22002X	2" Medium Temperature Anodized Aluminum Ring Blade™ Air Wipe + Filter with Auto Drain & Reg. with Gauge
22003X	3" Medium Temperature Anodized Aluminum Ring Blade™ Air Wipe + Filter with Auto Drain & Reg. with Gauge
22004X	4" Medium Temperature Anodized Aluminum Ring Blade™ Air Wipe + Filter with Auto Drain & Reg. with Gauge
22005X	5" Medium Temperature Anodized Aluminum Ring Blade™ Air Wipe + Filter with Auto Drain & Reg. with Gauge
22006X	6" Medium Temperature Anodized Aluminum Ring Blade™ Air Wipe + Filter with Auto Drain & Reg. with Gauge
22007X	7" Medium Temperature Anodized Aluminum Ring Blade™ Air Wipe + Filter with Auto Drain & Reg. with Gauge
20009	9" Medium Temperature Anodized Aluminum Ring Blade™ Air Wipe Only
20011	11" Medium Temperature Anodized Aluminum Ring Blade™ Air Wipe Only
21009	9" Medium Temperature Anodized Aluminum Ring Blade™ Air Wipe + Filter with Auto Drain
21011	11" Medium Temperature Anodized Aluminum Ring Blade™ Air Wipe + Filter with Auto Drain
22009	9" Medium Temperature Anodized Aluminum Ring Blade™ Air Wipe + Filter with Auto Drain & Reg. with Gauge
22011	11" Medium Temperature Anodized Aluminum Ring Blade™ Air Wipe + Filter with Auto Drain & Reg. with Gauge



**EXTRA STAINLESS STEEL SHIMS - .002" (.050 MM) FOR RING BLADE™ AIR WIPE SYSTEMS**

PART NO.	DESCRIPTION
20100	½" Stainless Steel Shim - .002" (.050 mm) for ½" Ring Blade™ Air Wipe System
20101	1" Stainless Steel Shim - .002" (.050 mm) for 1" Ring Blade™ Air Wipe System
20102	2" Stainless Steel Shim - .002" (.050 mm) for 2" Ring Blade™ Air Wipe System
20103	3" Stainless Steel Shim - .002" (.050 mm) for 3" Ring Blade™ Air Wipe System
20104	4" Stainless Steel Shim - .002" (.050 mm) for 4" Ring Blade™ Air Wipe System
20105	5" Stainless Steel Shim - .002" (.050 mm) for 5" Ring Blade™ Air Wipe System
20106	6" Stainless Steel Shim - .002" (.050 mm) for 6" Ring Blade™ Air Wipe System
20107	7" Stainless Steel Shim - .002" (.050 mm) for 7" Ring Blade™ Air Wipe System
20109	9" Stainless Steel Shim - .002" (.050 mm) for 9" Ring Blade™ Air Wipe System
20111	11" Stainless Steel Shim - .002" (.050 mm) for 11" Ring Blade™ Air Wipe System

**STAINLESS STEEL RING BLADE™ AIR WIPE SYSTEMS - UP TO 800°F (427°C)**

PART NO.	DESCRIPTION
20000XS-316L	½" High Temperature 316L Stainless Steel Ring Blade™ Air Wipe only
20001XS-316L	1" High Temperature 316L Stainless Steel Ring Blade™ Air Wipe only
20002XS-316L	2" High Temperature 316L Stainless Steel Ring Blade™ Air Wipe only
20003XS-316L	3" High Temperature 316L Stainless Steel Ring Blade™ Air Wipe only
20004XS-316L	4" High Temperature 316L Stainless Steel Ring Blade™ Air Wipe only
20005XS-316L	5" High Temperature 316L Stainless Steel Ring Blade™ Air Wipe only
20006XS-316L	6" High Temperature 316L Stainless Steel Ring Blade™ Air Wipe only
20007XS-316L	7" High Temperature 316L Stainless Steel Ring Blade™ Air Wipe only
21000XS-316L	½" High Temperature 316L Stainless Steel Ring Blade™ Air Wipe plus Filter with Auto Drain
21001XS-316L	1" High Temperature 316L Stainless Steel Ring Blade™ Air Wipe plus Filter with Auto Drain
21002XS-316L	2" High Temperature 316L Stainless Steel Ring Blade™ Air Wipe plus Filter with Auto Drain
21003XS-316L	3" High Temperature 316L Stainless Steel Ring Blade™ Air Wipe plus Filter with Auto Drain
21004XS-316L	4" High Temperature 316L Stainless Steel Ring Blade™ Air Wipe plus Filter with Auto Drain
21005XS-316L	5" High Temperature 316L Stainless Steel Ring Blade™ Air Wipe plus Filter with Auto Drain
21006XS-316L	6" High Temperature 316L Stainless Steel Ring Blade™ Air Wipe plus Filter with Auto Drain
21007XS-316L	7" High Temperature 316L Stainless Steel Ring Blade™ Air Wipe plus Filter with Auto Drain
22000XS-316L	½" High Temperature 316L Stainless Steel Ring Blade™ Air Wipe + Filter with Auto Drain & Reg. with Gauge
22001XS-316L	1" High Temperature 316L Stainless Steel Ring Blade™ Air Wipe + Filter with Auto Drain & Reg. with Gauge
22002XS-316L	2" High Temperature 316L Stainless Steel Ring Blade™ Air Wipe + Filter with Auto Drain & Reg. with Gauge
22003XS-316L	3" High Temperature 316L Stainless Steel Ring Blade™ Air Wipe + Filter with Auto Drain & Reg. with Gauge
22004XS-316L	4" High Temperature 316L Stainless Steel Ring Blade™ Air Wipe + Filter with Auto Drain & Reg. with Gauge
22005XS-316L	5" High Temperature 316L Stainless Steel Ring Blade™ Air Wipe + Filter with Auto Drain & Reg. with Gauge
22006XS-316L	6" High Temperature 316L Stainless Steel Ring Blade™ Air Wipe + Filter with Auto Drain & Reg. with Gauge
22007XS-316L	7" High Temperature 316L Stainless Steel Ring Blade™ Air Wipe + Filter with Auto Drain & Reg. with Gauge

**EXTRA 316L STAINLESS STEEL SHIMS - .002" (.050 MM) FOR STAINLESS RING BLADE™ AIR WIPE SYSTEMS**

PART NO.	DESCRIPTION
20100-316L SYSTEM	½" 316L Stainless Steel Shim - .002" (.050 mm) for ½" 316L Stainless Ring Blade™ Air Wipe System
20101-316L SYSTEM	1" 316L Stainless Steel Shim - .002" (.050 mm) for 1" 316L Stainless Ring Blade™ Air Wipe System
20102-316L SYSTEM	2" 316L Stainless Steel Shim - .002" (.050 mm) for 2" 316L Stainless Ring Blade™ Air Wipe System
20103-316L SYSTEM	3" 316L Stainless Steel Shim - .002" (.050 mm) for 3" 316L Stainless Ring Blade™ Air Wipe System
20104-316L SYSTEM	4" 316L Stainless Steel Shim - .002" (.050 mm) for 4" 316L Stainless Ring Blade™ Air Wipe System
20105-316L SYSTEM	5" 316L Stainless Steel Shim - .002" (.050 mm) for 5" 316L Stainless Ring Blade™ Air Wipe System
20107-316L SYSTEM	7" 316L Stainless Steel Shim - .002" (.050 mm) for 7" 316L Stainless Ring Blade™ Air Wipe System

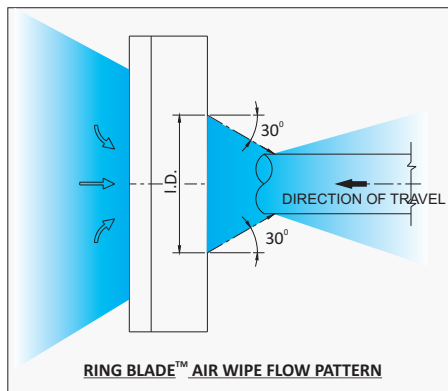
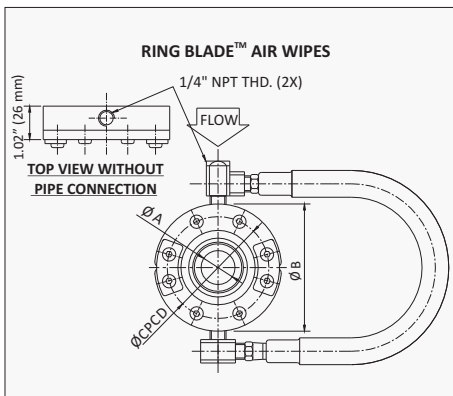

**RING BLADE™ AIR WIPE SYSTEM**



## AIR AMPLIFIERS

Blowoff, clean, cool and dry as well as vent and exhaust with no moving parts

### WHAT ARE THEY - REASONS TO USE

Air Amplifiers or “Air Movers” are a simple, inexpensive device with virtually no maintenance that can convey fumes, smoke, light weight materials, and move a high volume of air for cooling, blowoff and drying applications. They use the “coanda effect” which entrains a large amount of surrounding air using only a small amount of compressed air. The effect is an amplification of up to 17 times the airflow or more (depending on the size) with reduced noise levels. Using only compressed air, the output flow and vacuum is easily controlled by adjusting or opening the air gap and/or inlet pressure. Either end of the amplifier may be ducted to address all kinds of applications from bringing in fresh air into an area to removing nasty fumes. Be wary of extremely high unrealistic or unsubstantiated amplification ratios claimed by some companies.

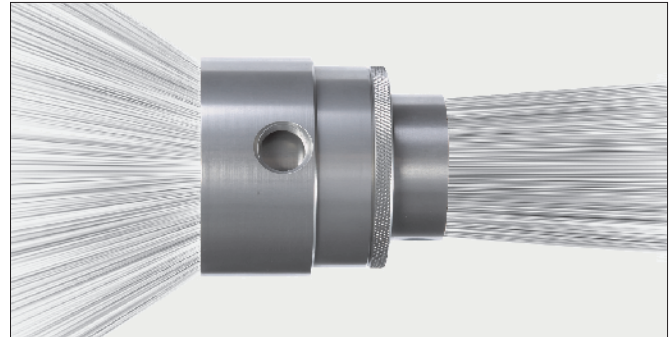

### AIR AMPLIFIER FEATURES:

- ▶ No moving parts.
- ▶ Compact design, simple, lightweight and portable.
- ▶ Driven by air not electricity.
- ▶ Replaces fans used for blowoff, cleaning, drying, cooling and conveying.
- ▶ High airflow amplification.
- ▶ Instant on-off, no electricity or explosion hazard.

### AIR AMPLIFIER BENEFITS:

- ▶ Longer life in difficult environments than competitive models.
- ▶ Lower compressed air consumption than ejectors and venturi.
- ▶ Maintenance free with output easily controlled, safe to use.

### AIR AMPLIFIER ADVANTAGES OVER FANS:

- ▶ Compact design, simple, lightweight and portable.
- ▶ Driven by air, not electricity for safety.
- ▶ No moving parts hence safer and maintenance free.
- ▶ Each end can be ducted for light conveying applications.

### SELECTION

The fixed unit being made of heavy duty zinc die cast is more ideal in rough environments where corrosion is not an issue. The aluminum Adjustable Air Amplifiers are light-weight and flexible because of being adjustable. Stainless steel adjustable units are meant for corrosive environments and for food/pharmaceutical applications.

### TYPES OF AIR AMPLIFIERS



**STANDARD “FIXED” AIR AMPLIFIER:** made of zinc die cast system is solid and perform as well or better than many supposedly patented designs when used in similar applications. The gap can be adjusted by adding shims. Five sizes are available.



**ADJUSTABLE AIR AMPLIFIER:** made of anodized aluminum or stainless steel for high temperature or food applications. The customer can set the gap and lock it in place using a lock ring. Three sizes are available.

### SPECIAL DESIGNS

Special designs are available to meet unique customer specifications. Specially treated stainless steel units have been made for a specific medical application and threaded adjustable versions have been made for a machine builder. Different materials can be provided as well as special sizes to fit any specific application.



**Mounting and holding systems are available for the Air Amplifiers. Fully flexible positioning. See Accessories**

**STANDARD AIR AMPLIFIER - HOW IT WORKS:**

A small amount of compressed air enters the annular chamber at point (A). That is then throttled through a small ring nozzle at high velocity and into the inside of the Amplifier over a “coanda” profile. The compressed air stream clings to the “coanda” profile as it enters the inside walls of the amplifier and thereby creating a vacuum that induces the outside air at point (B). Converting the pressure into amplified airflow. The amplified airflow leaves at the exit at point (C). Airflow is further amplified downstream at point (D). By entraining additional air from the surroundings at the exit.

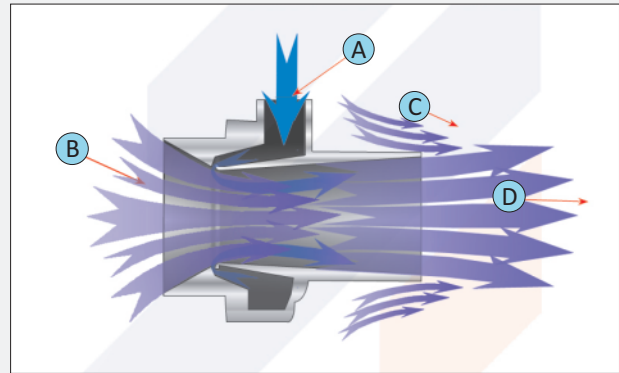

**AMPLIFIERS-RATIOS (APPROX.)**

Model AM10: 6.5:1
Model AM20: 14:1
Model AM40: 15:1
Model AM75: 15:1
Model AM125: 16:1

MODEL NO.	A Inches (MM)	B Inches (MM)	C Inches (MM)	D Inches (MM)	E Inches (MM)	F Inches (MM)	G Inches (MM)	H Inches (MM)	I Inches (MM)	J Inches (MM)	K (NPT)
AM10	0.40" (10.16)	1.30" (33.1)	0.99" (25.2)	1.89" (48)	2.24" (57)	0.19" (4.8)	0.16" (4)	0.59" (15)	0.75" (19)	1.59" (40.4)	1/8"
AM20	0.81" (20.6)	1.86" (47.2)	1.50" (38)	2.39" (60.8)	3.03" (76.9)	0.27" (6.8)	0.20" (5)	0.59" (15)	1.27" (32.2)	2.16" (54.8)	1/4"
AM40	1.59" (40.4)	3.15" (80)	2.93" (74.5)	3.54" (90)	4.18" (106.1)	0.29" (7.4)	0.24" (6.2)	0.79" (20)	2.03" (51.6)	2.84" (72.2)	3/8"
AM75	2.98" (75.8)	5.91" (150)	4.96" (126)	6.89" (175)	8.46" (215)	0.53" (13.5)	0.51" (13)	1.18" (30)	3.98" (101)	5.94" (151)	1/2"
AM125	4.92" (125)	10.24" (260)	7.09" (180)	-	-	-	-	0.79" (20)	7.80" (198)	16.54" (420)	3/4"

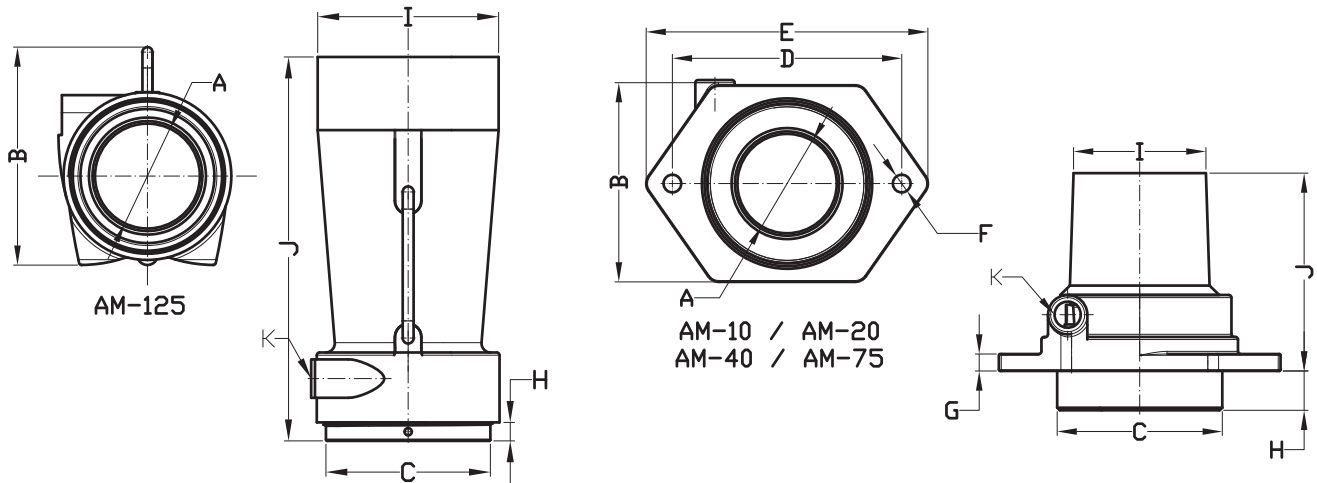

**AM10**

**AMPLIFICATION RATIO = 6.5:1 (SEE ADDENDUM-I)**

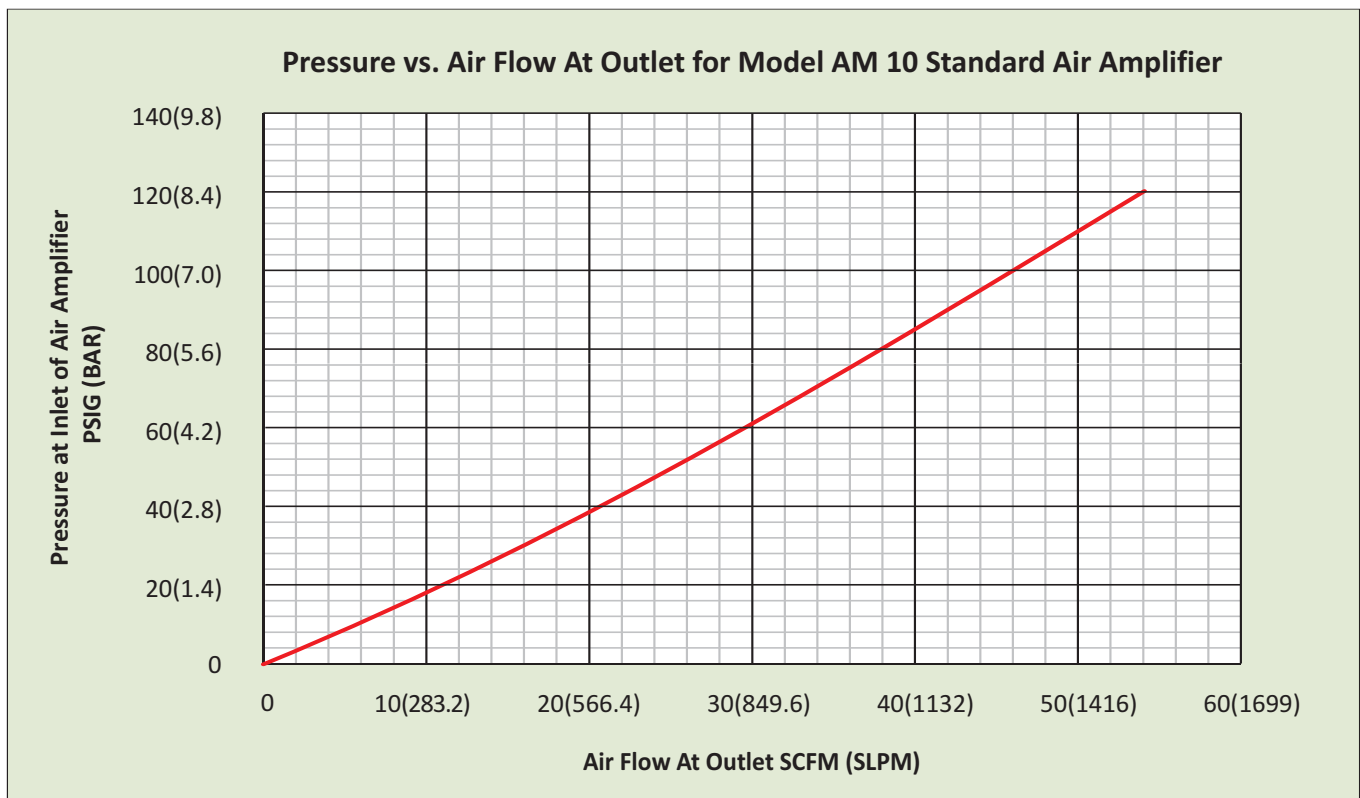
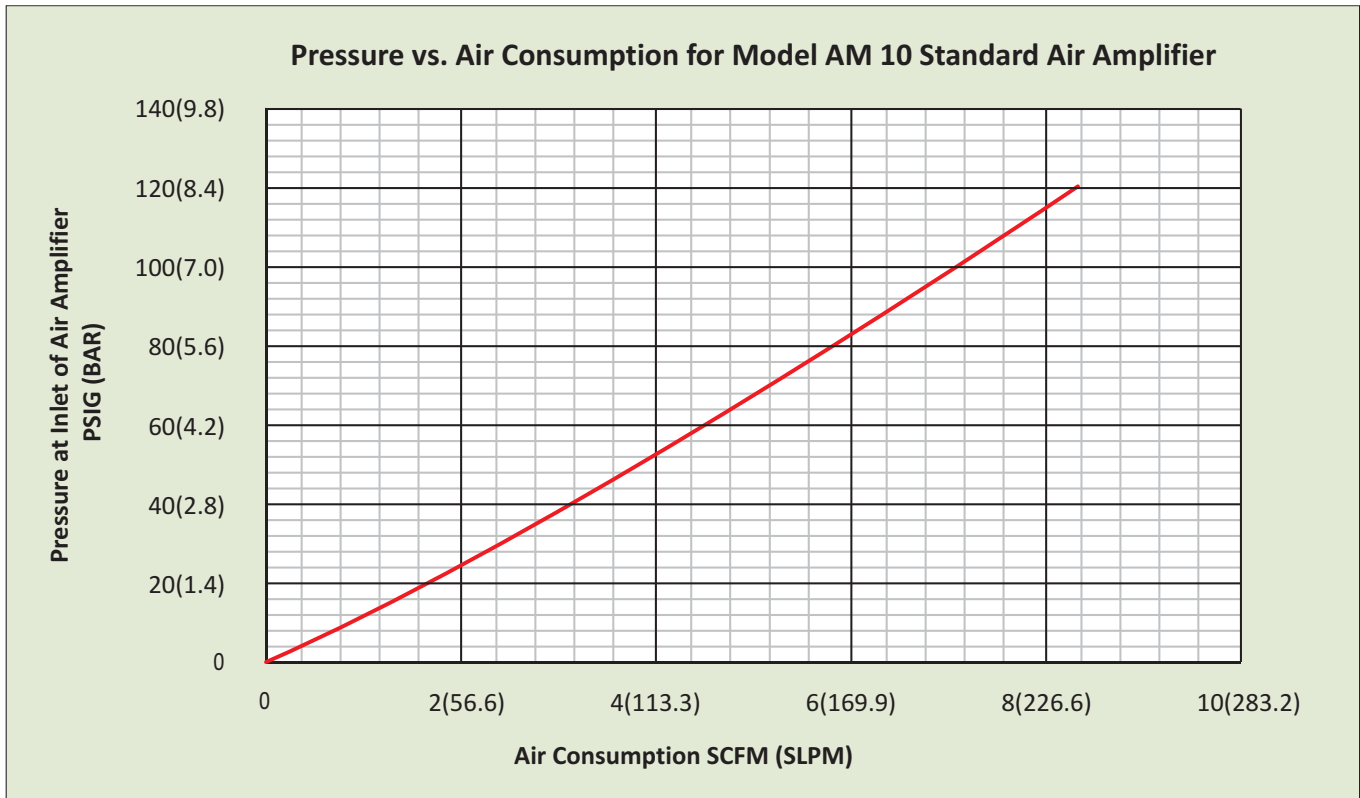

**AM10**

**Pressure vs. Velocity At Outlet for Model AM 10 Standard Air Amplifier**

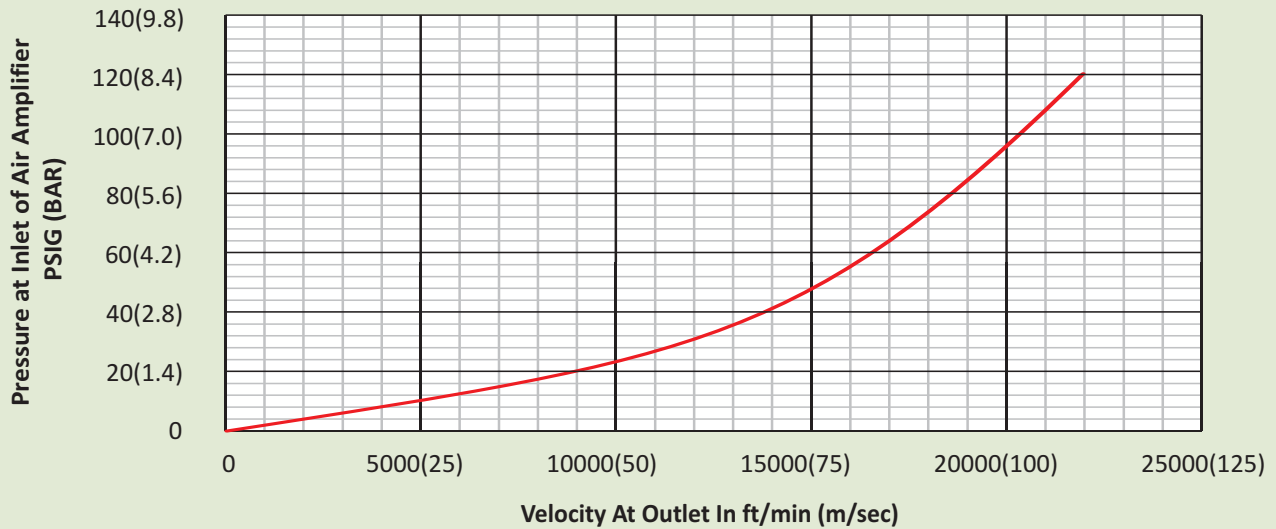

**Pressure vs. Velocity 6" From Outlet for Model AM 10 Standard Air Amplifier**

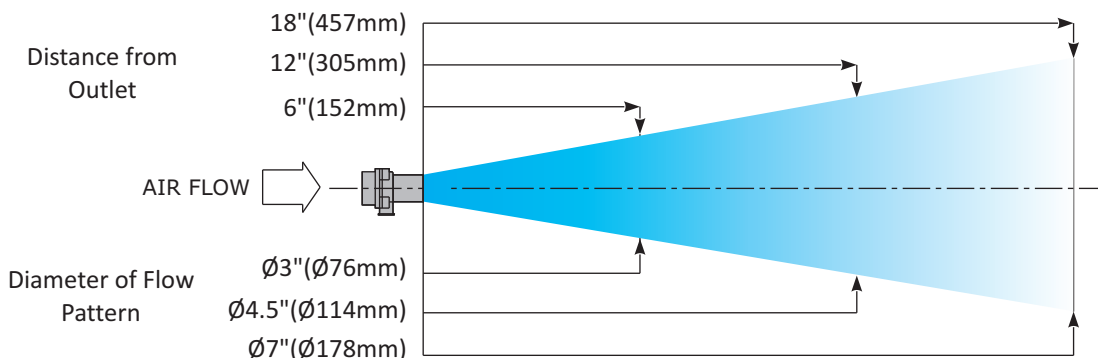
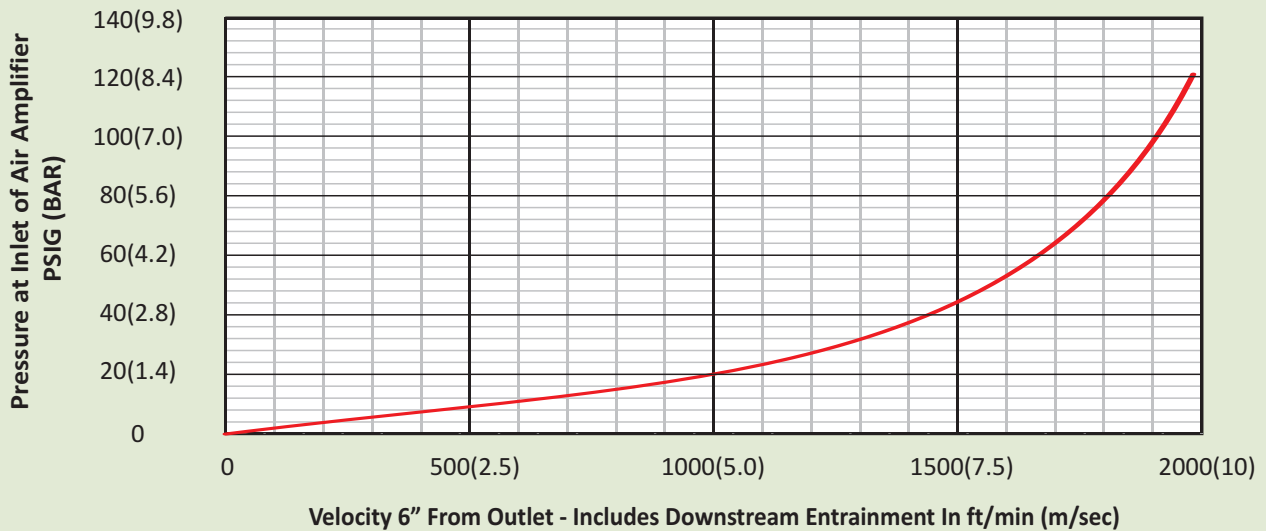

AM20

AMPLIFICATION RATIO = 14:1 (SEE ADDENDUM-I)

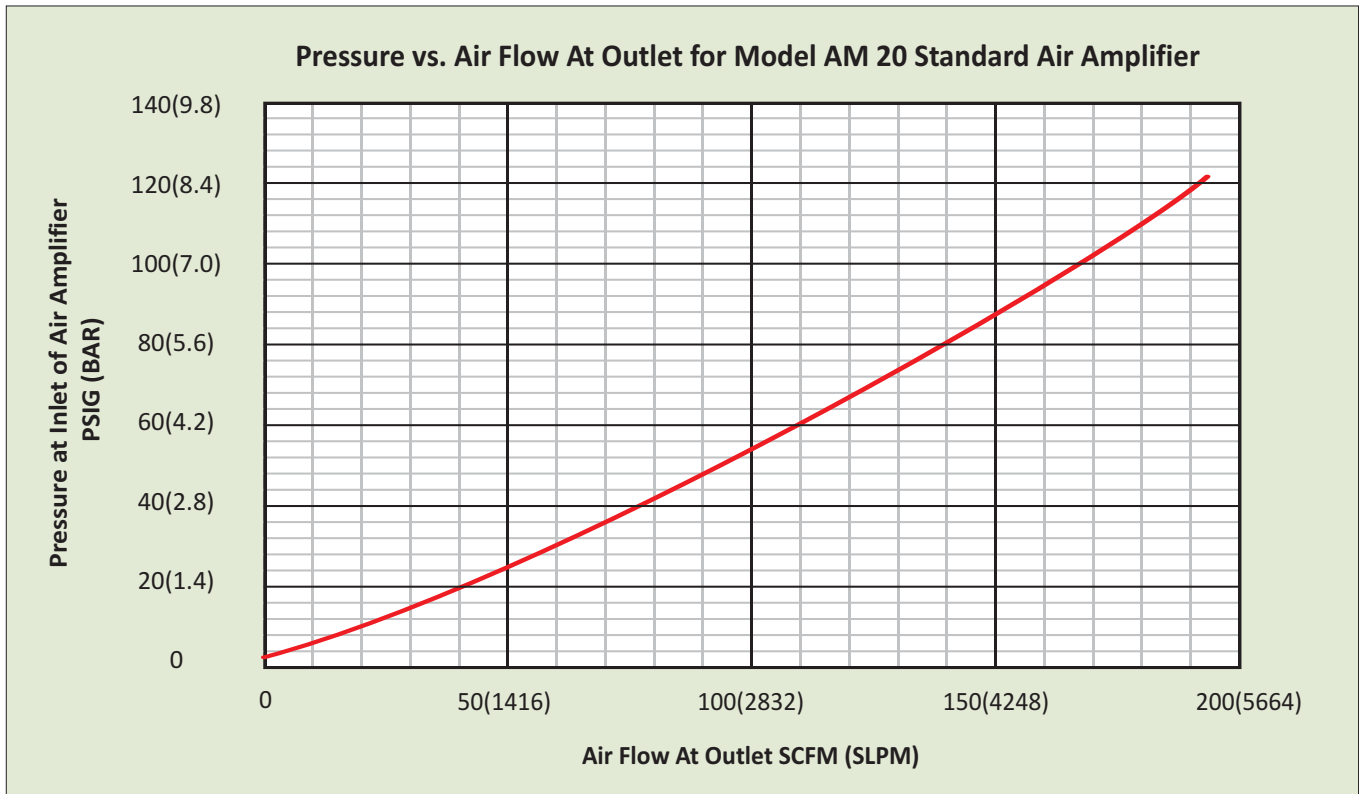
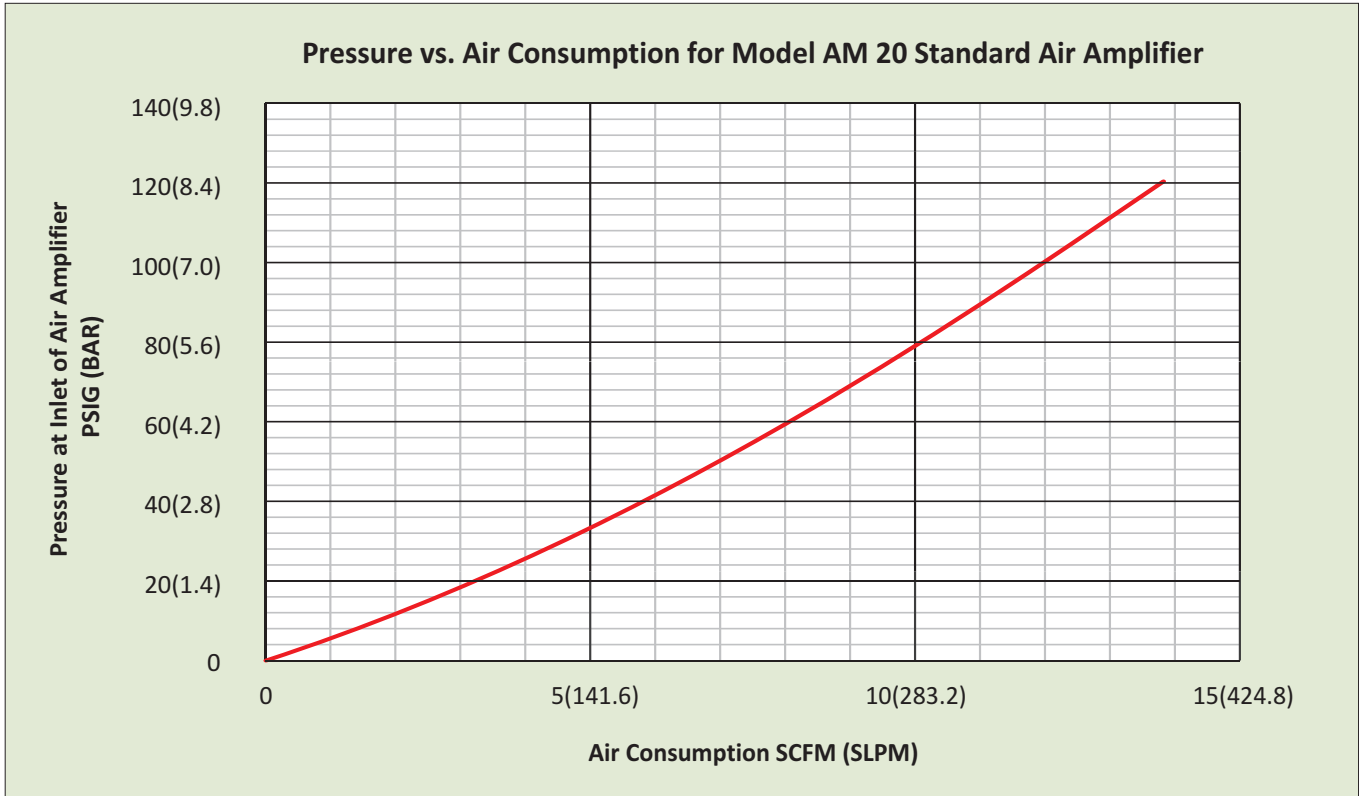

**AM20**

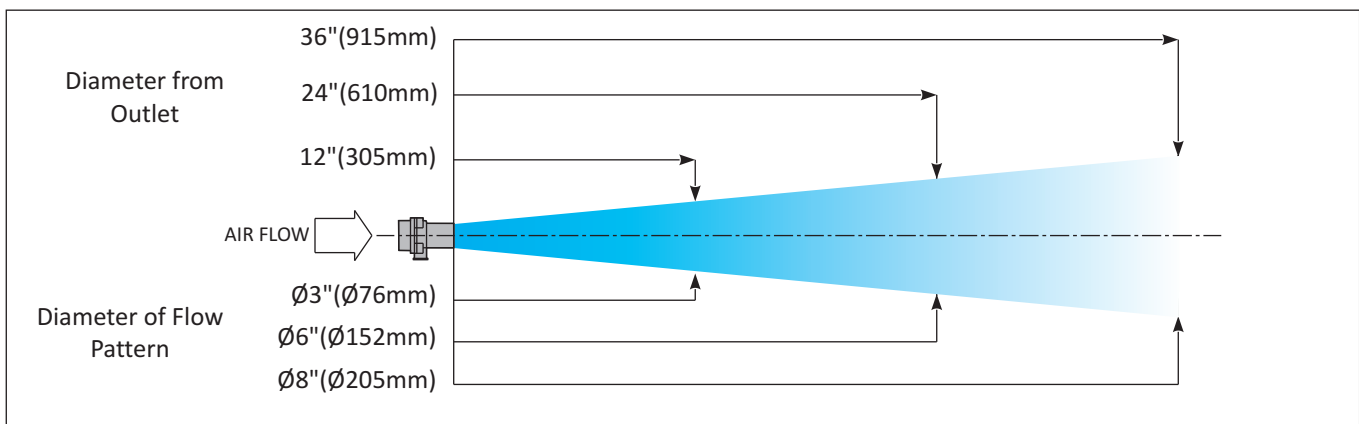
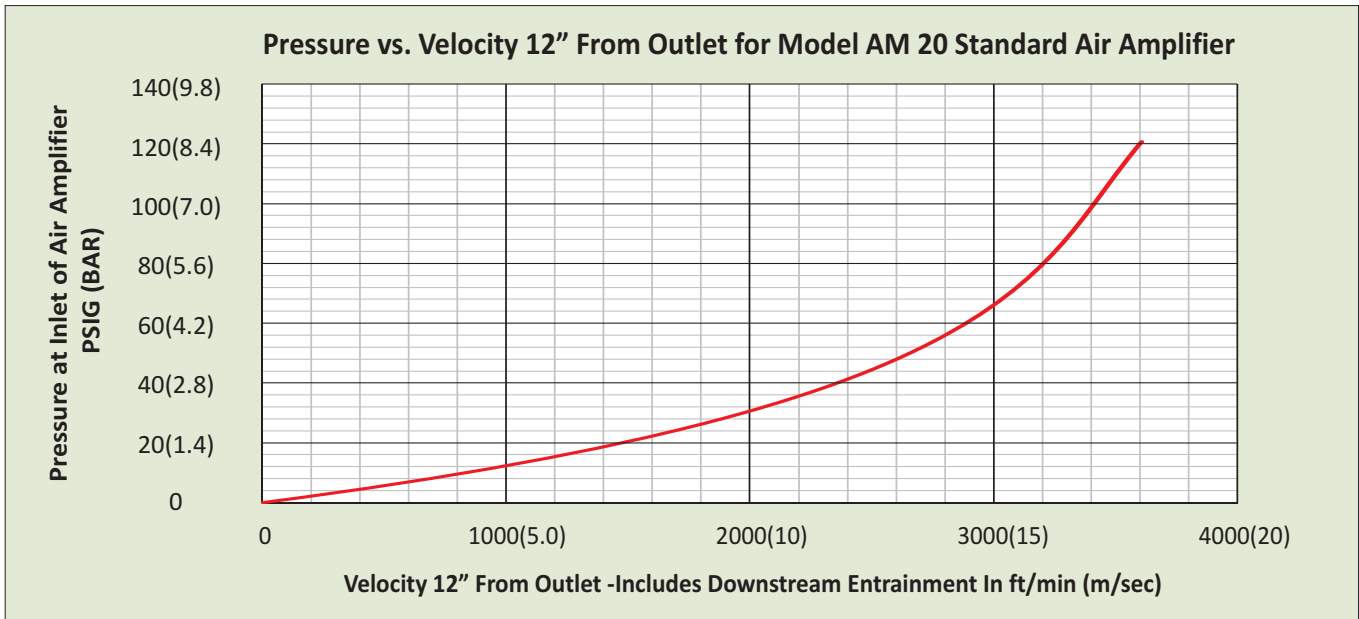
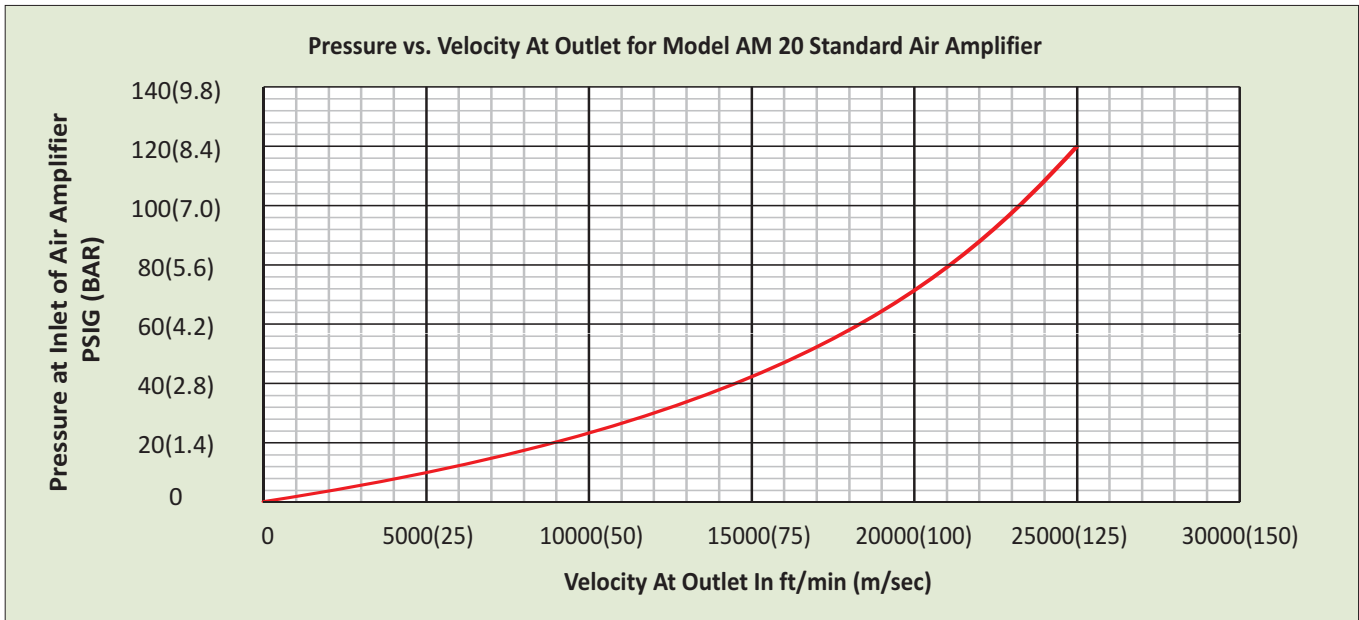

AM40

AMPLIFICATION RATIO = 15:1 (SEE ADDENDUM-I)

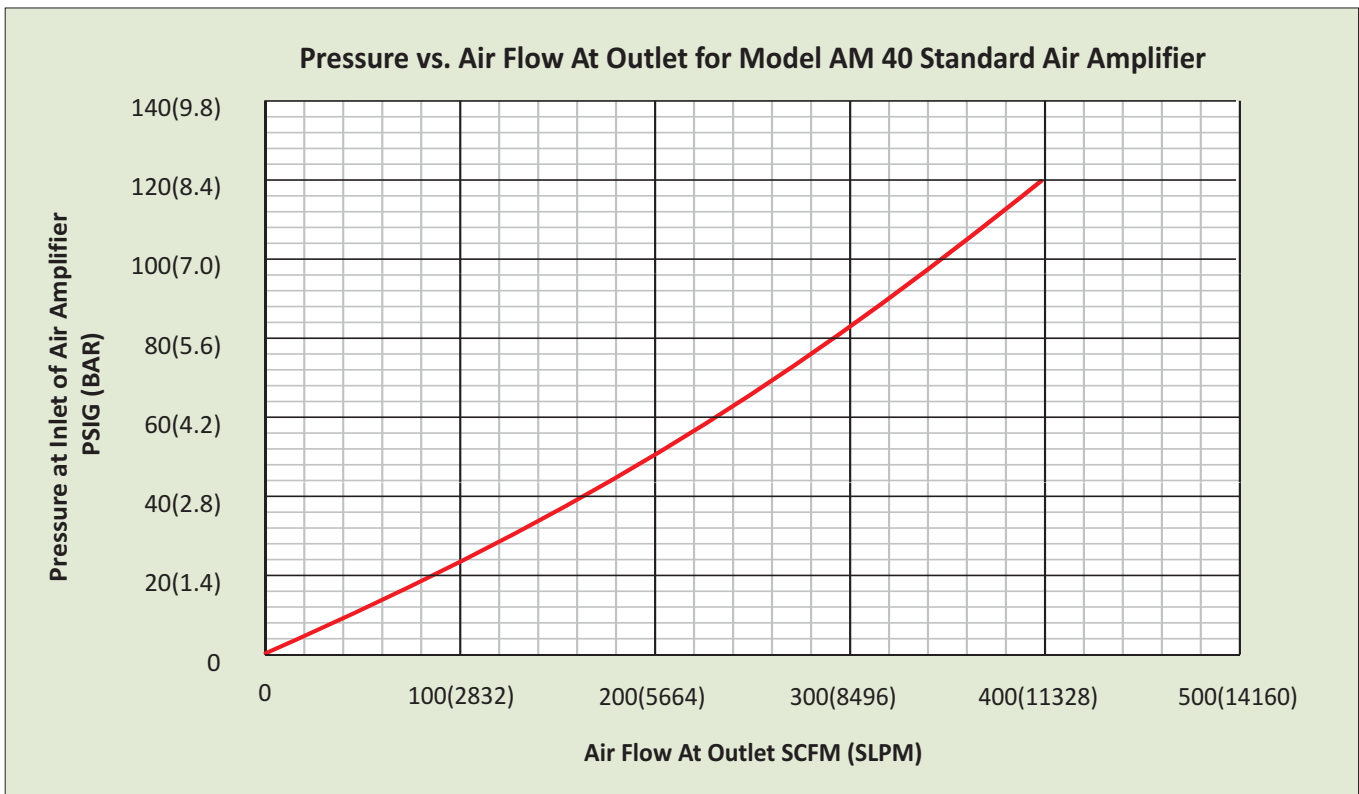
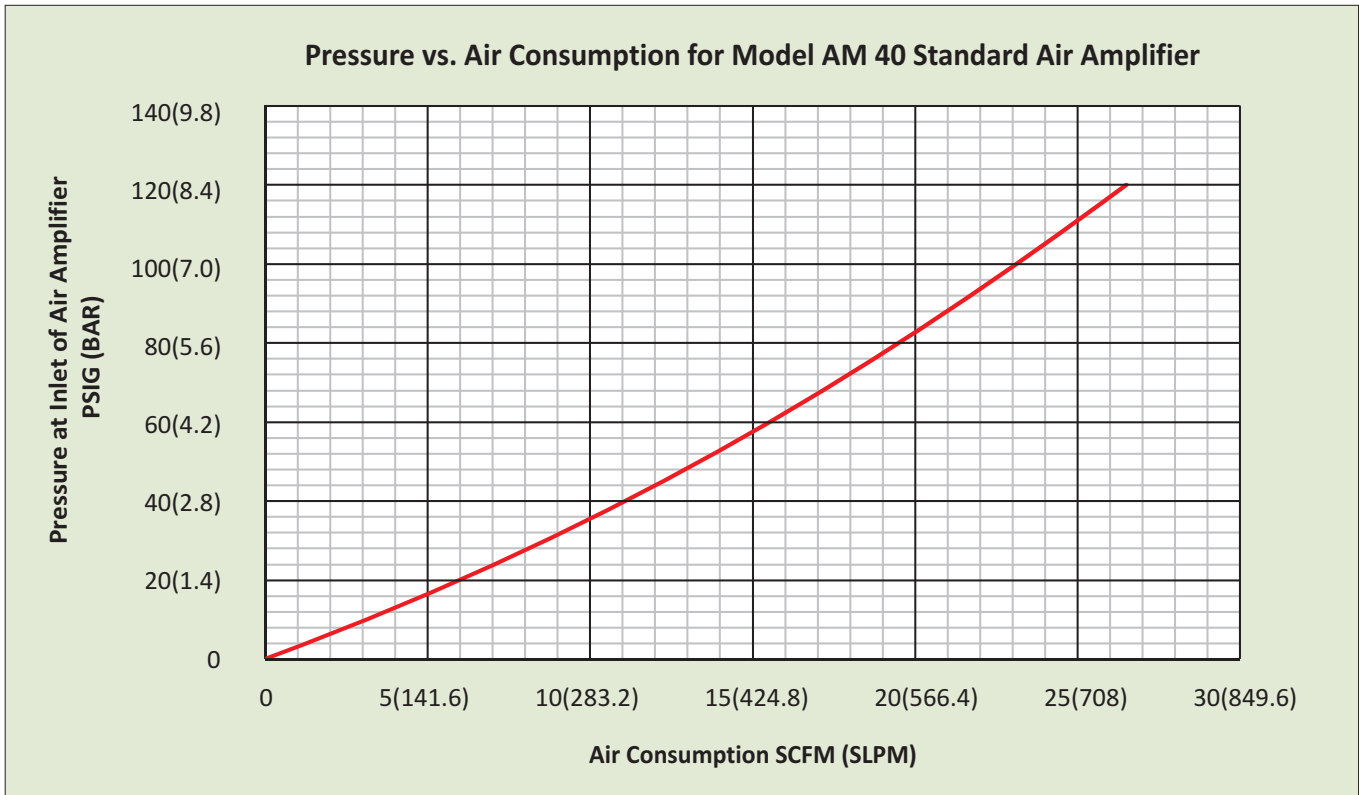

**AM40**

**Pressure vs. Velocity At Outlet for Model AM 40 Standard Air Amplifier**

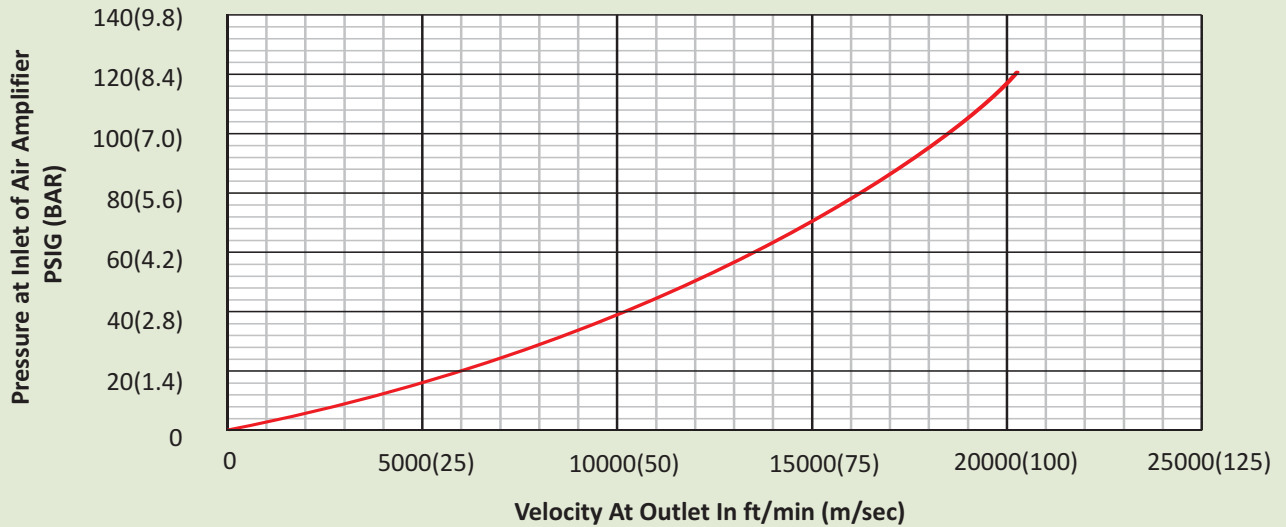

**Pressure vs. Velocity 12" From Outlet for Model AM 40 Standard Air Amplifier**

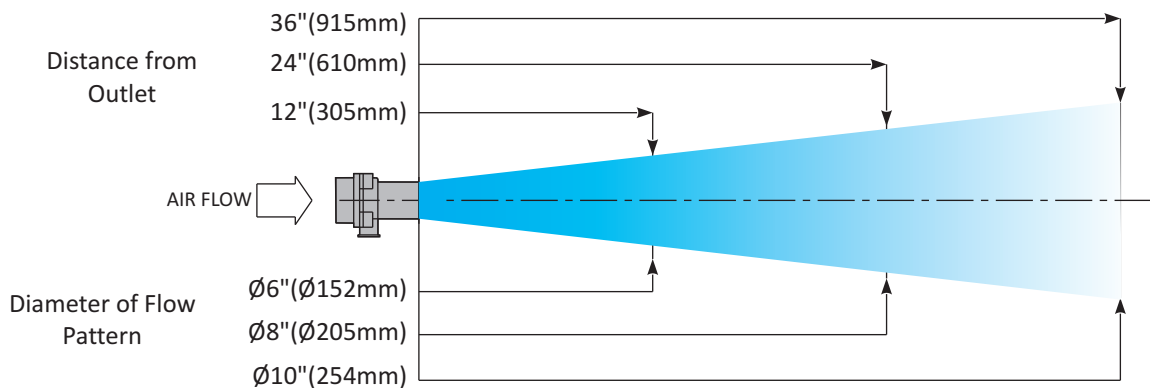
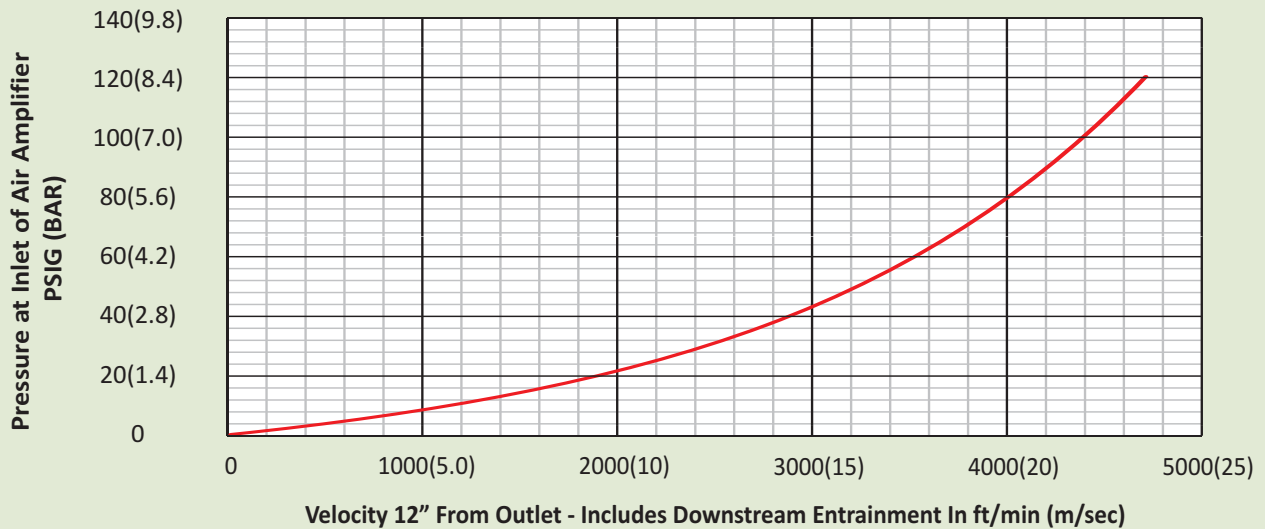

**AIR AMPLIFIERS**



AM75

AMPLIFICATION RATIO = 15:1 (SEE ADDENDUM - I)

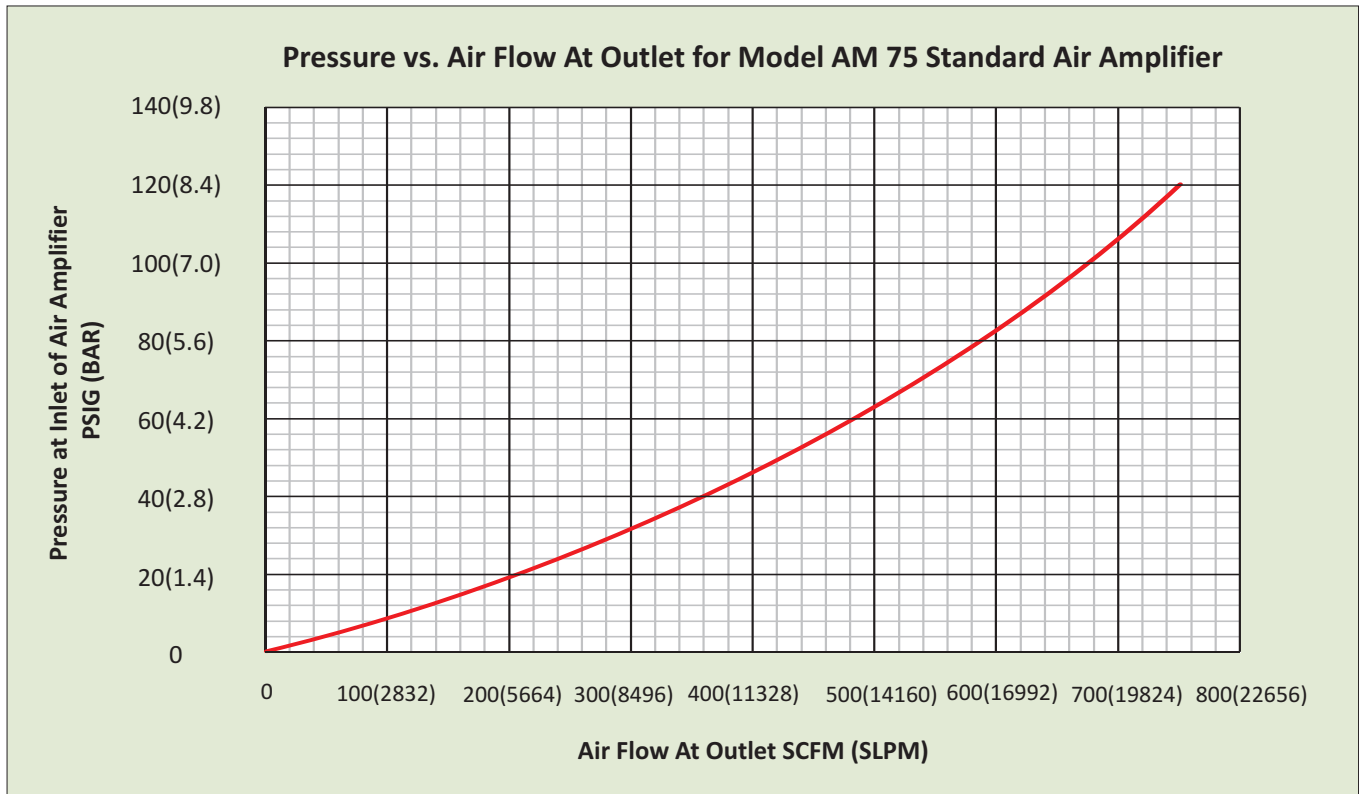
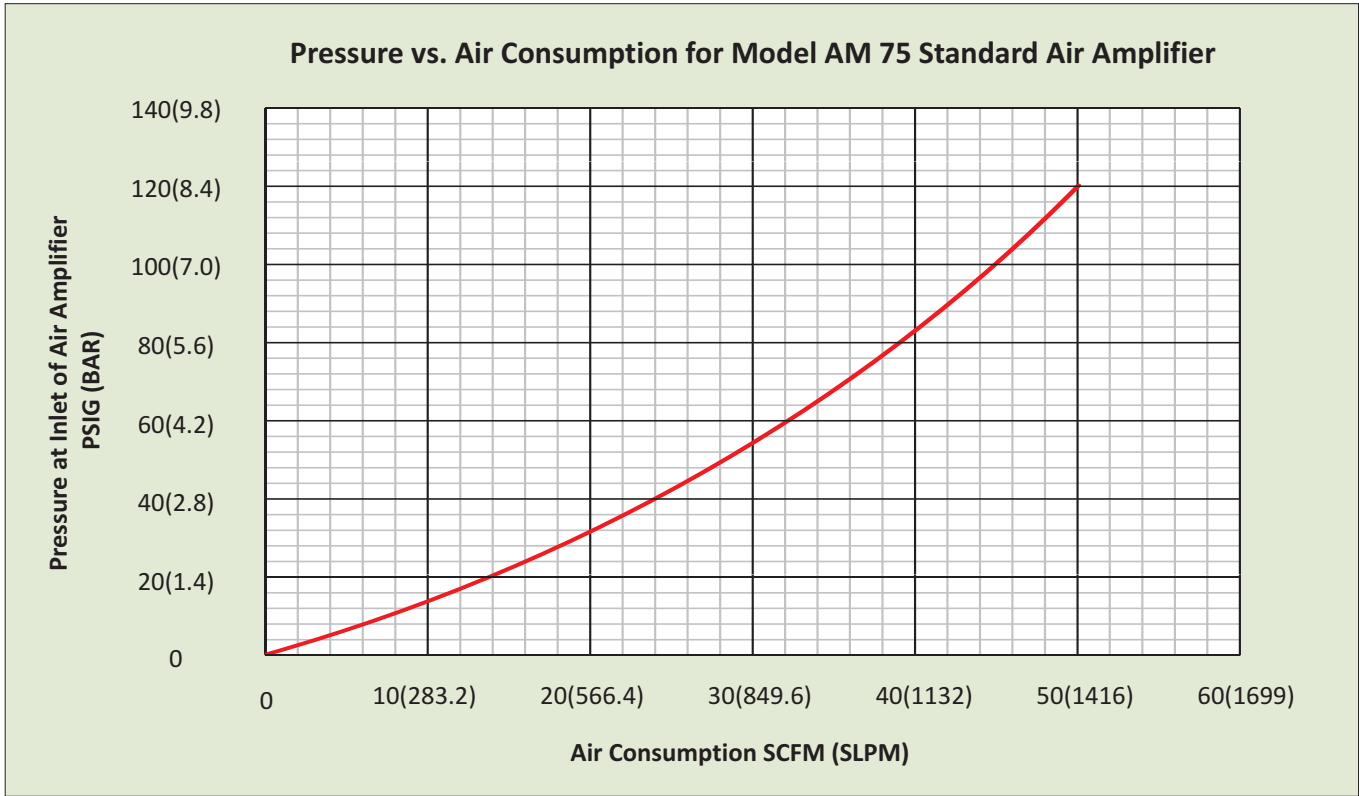

**AM75**

**Pressure vs. Velocity At Outlet for Model AM 75 Standard Air Amplifier**

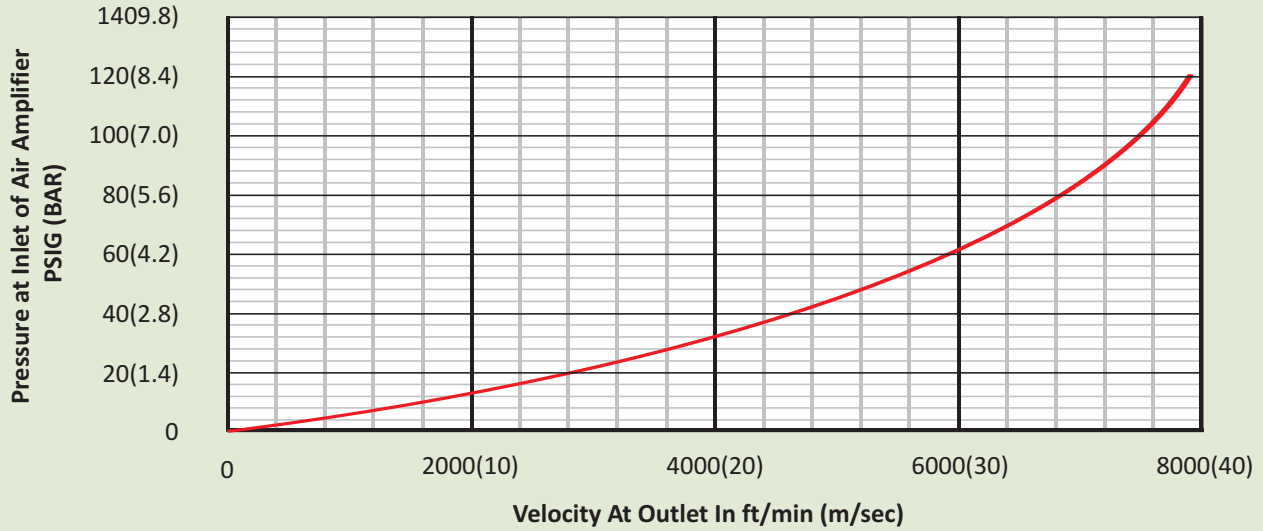

**Pressure vs. Velocity 12" From Outlet for Model AM 75 Standard Air Amplifier**

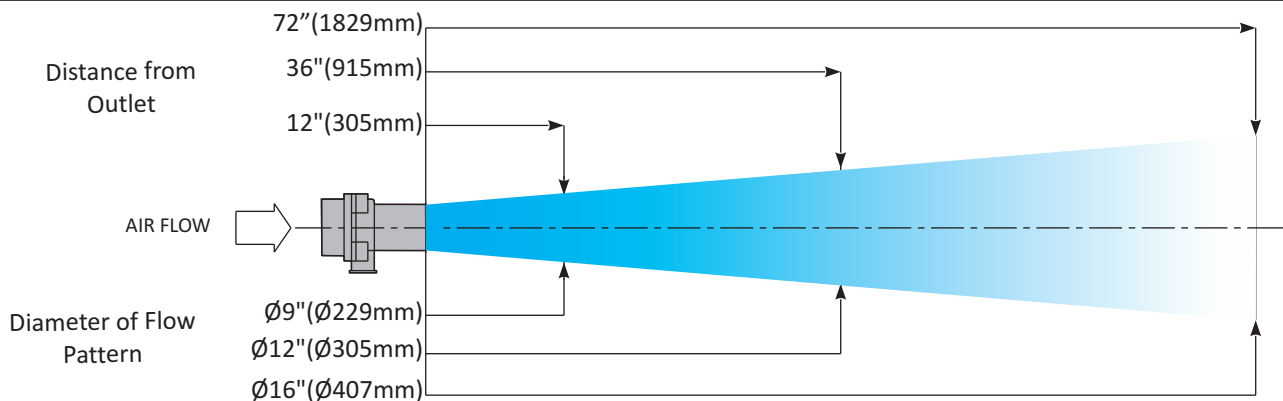
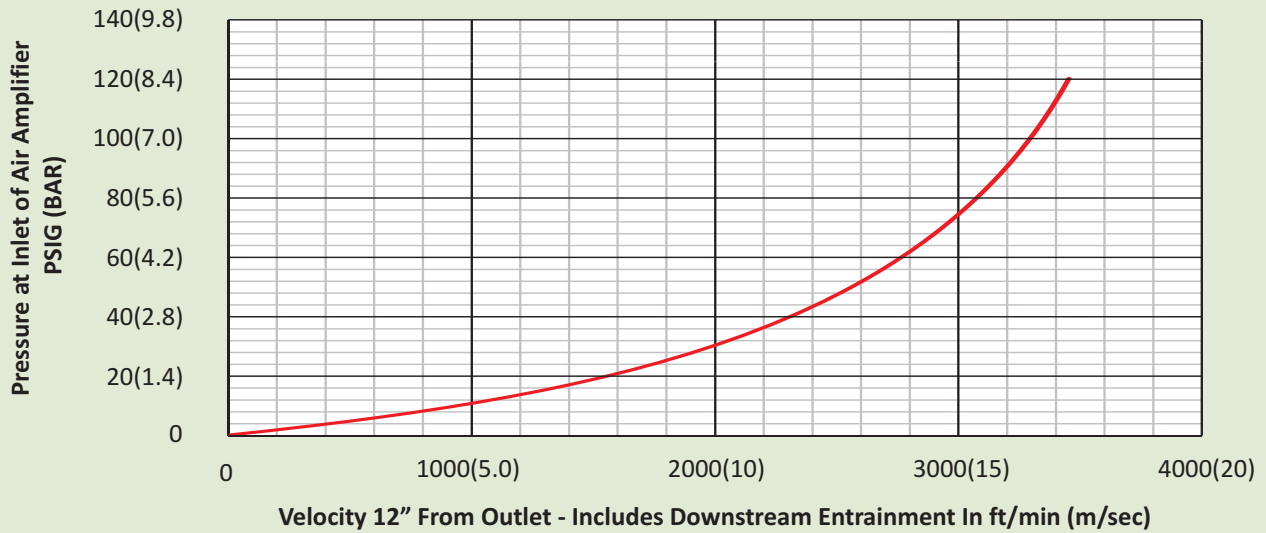

AM125

AMPLIFICATION RATIO = 16:1 (SEE ADDENDUM - I)

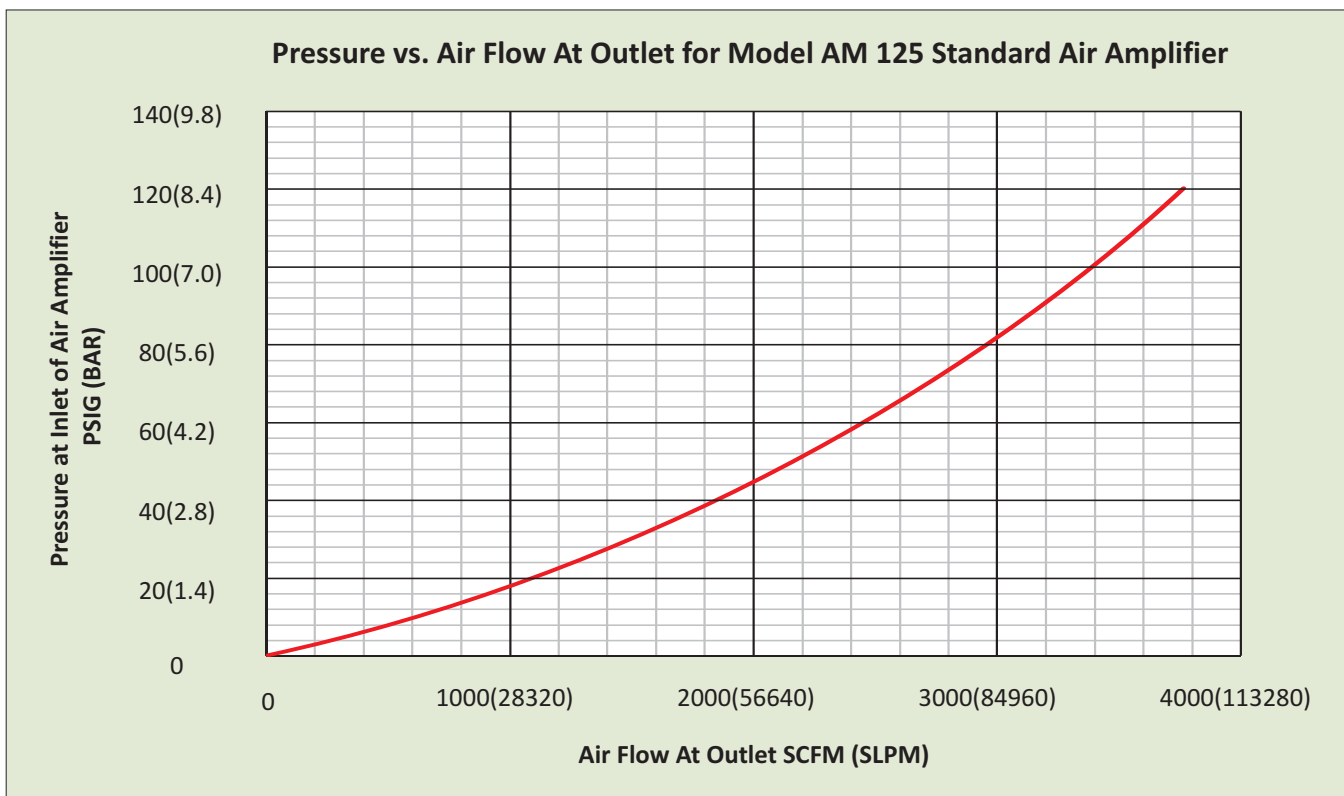
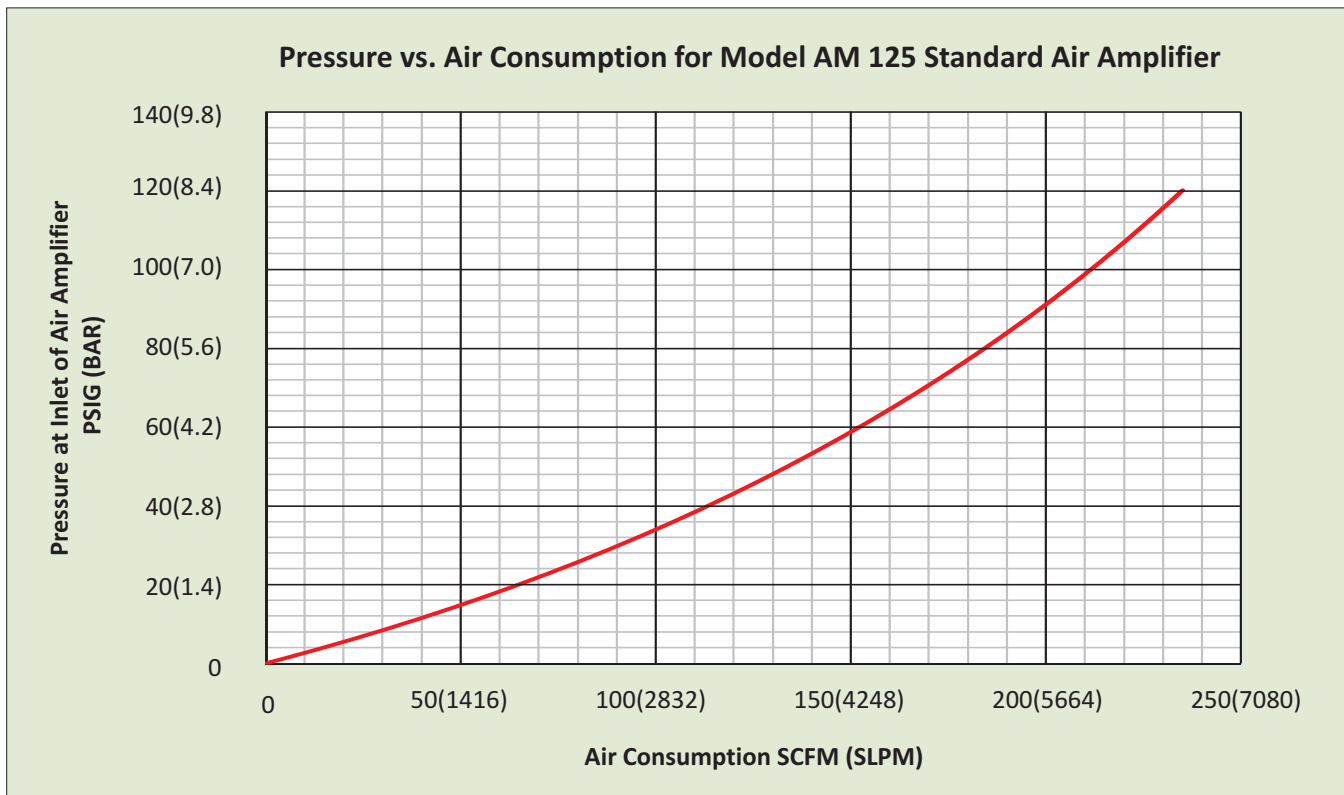

**AM125**

**Pressure vs. Velocity At Outlet for Model AM 125 Standard Air Amplifier**

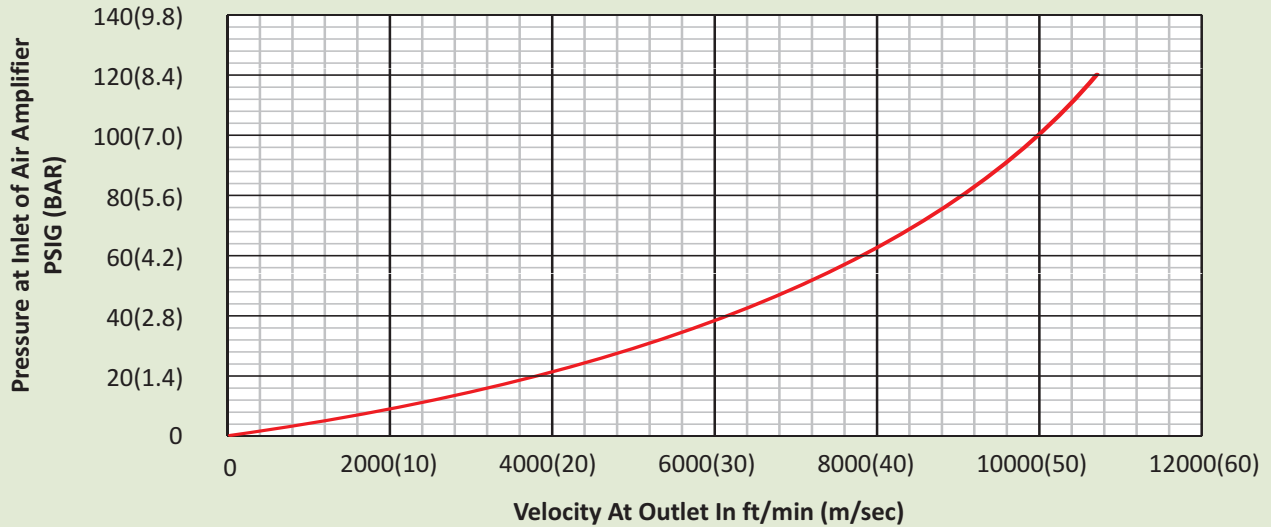

**Pressure vs. Velocity 12" From Outlet for Model AM 125 Standard Air Amplifier**

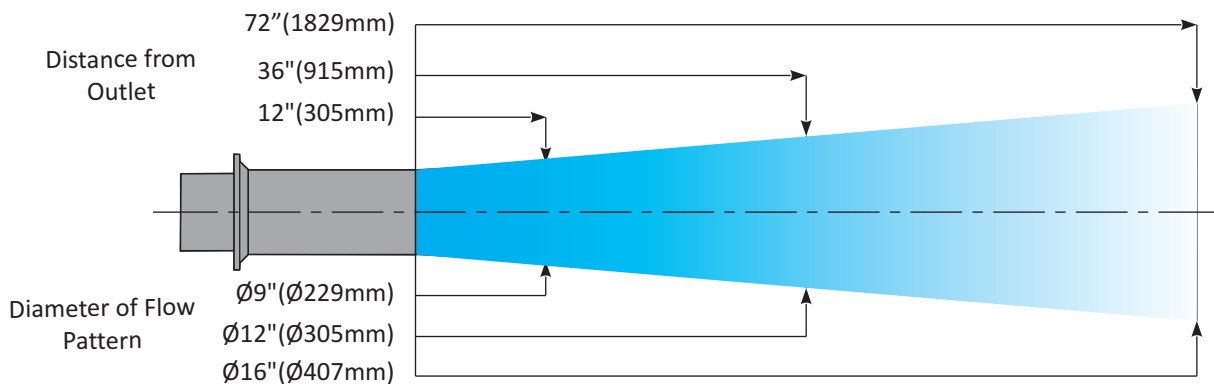
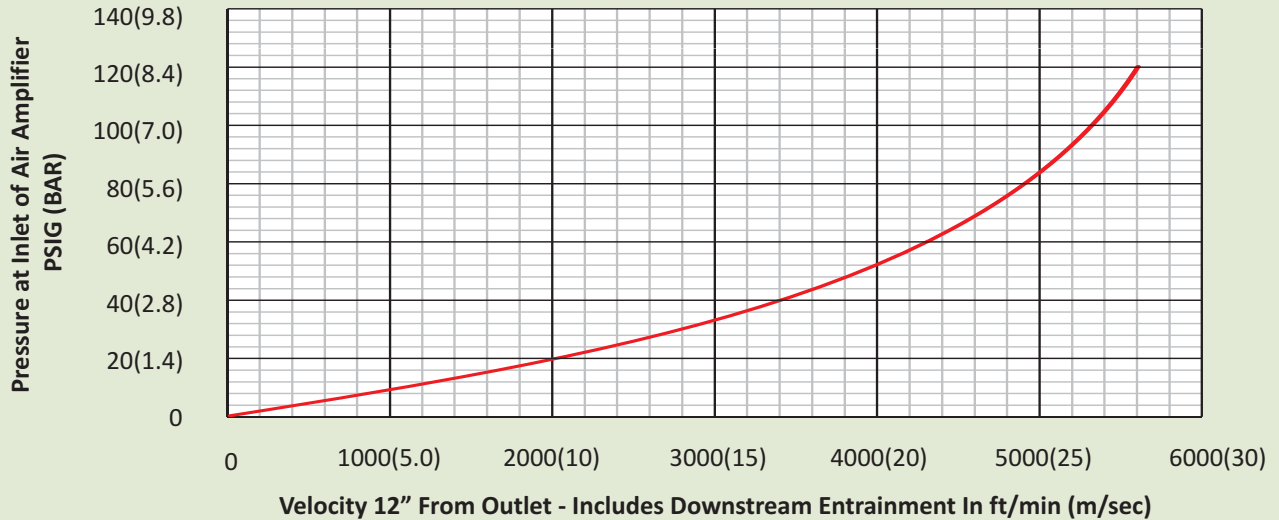

**CAST ZINC FIXED STANDARD AIR AMPLIFIERS**

PART NO.	DESCRIPTION
AM10	3/4" Zinc Alloy Amplifier
AM20	1-1/4" Zinc Alloy Amplifier
AM40	2" Zinc Alloy Amplifier
AM75	4" Zinc Alloy Amplifier
AM125	8" Zinc Alloy Amplifier
AM10-1	3/4" Amplifier plus Filter with Auto Drain
AM20-1	1-1/4" Amplifier plus Filter with Auto Drain
AM40-1	2" Amplifier plus Filter with Auto Drain
AM75-1	4" Amplifier plus Filter with Auto Drain
AM125-1	8" Amplifier plus Filter with Auto Drain
AM10-2	3/4" Amplifier plus Filter with Auto Drain plus Regulator with Gauge
AM20-2	1-1/4" Amplifier plus Filter with Auto Drain plus Regulator with Gauge
AM40-2	2" Amplifier plus Filter with Auto Drain plus Regulator with Gauge
AM75-2	4" Amplifier plus Filter with Auto Drain plus Regulator with Gauge
AM125-2	8" Amplifier plus Filter with Auto Drain plus Regulator with Gauge
SH10-2	Stainless Steel Shim, .002" for AM10
SH10-3	Stainless Steel Shim, .003" for AM10
SH20-2	Stainless Steel Shim, .002" for AM20
SH20-3	Stainless Steel Shim, .003" for AM20
SH40-2	Stainless Steel Shim, .002" for AM40
SH40-3	Stainless Steel Shim, .003" for AM40
SH75-2	Stainless Steel Shim, .002" for AM75
SH75-3	Stainless Steel Shim, .003" for AM75
SH125-3	Stainless Steel Shim, .003" for AM125

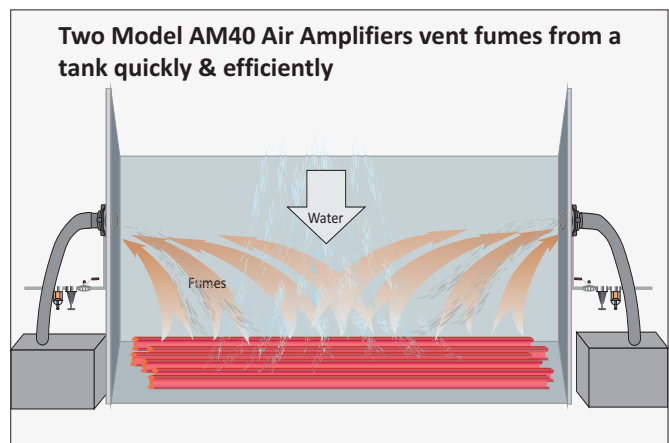
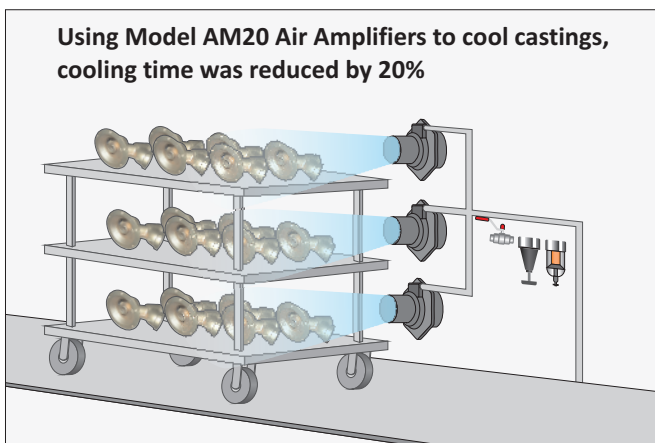

**ADJUSTABLE AIR AMPLIFIER - HOW IT WORKS:**

A large volume of surrounding air is induced into the Amplifier at point (A) by the action of a small amount of compressed air which enters the annular chamber at point (B) that is then throttled through a small ring Nozzle at high velocity and into the inside of the Amplifier over a coanda profile. The compressed air stream clings to the coanda profile as it enters the inside walls of the Amplifier and thereby creating a vacuum that induces the outside air converting the pressure into amplified airflow. The amplified airflow leaves at the exit at point (C). Airflow is further amplified downstream at point (D) by entraining additional air from the surroundings at the exit.

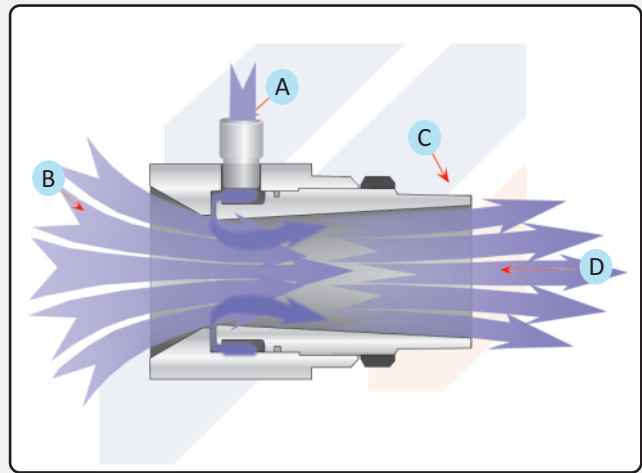

**ADJUSTABLE AIR AMPLIFIER SPECIFICATIONS:**

Normally set to .002" (.05mm) gap if greater air force is required, the gap is adjustable. The first two sizes of adjustable air amplifiers come in two versions – unmarked regular versions and marked to gauge the gap setting from 0 to 1.5 mm.

**ADJUSTABLE AIR AMPLIFIER RATIOS (APPROX.)**

Models 40001, 40001G and 40001S: 15:1

Models 40002, 40002G and 40001S: 16:1

Models 40003 and 40003S: 17:1

Model	A Inches (MM)	B Inches (MM)	C Inches (MM)	D Inches (MM)	E Inches (MM)	F INLET
40001 / 40001S	2.875"	1.74"	1.25"	1.98"	1.91"	1/4"
	(73)	(44.2)	(31.75)	(50.3)	(48.4)	NPT
40002 / 40002S	3.25"	2.75"	2.0"	2.98"	2.19"	3/8"
	(82.6)	(69.85)	(50.80)	(75.7)	(55.6)	NPT
40003 / 40003S	5.1"	5.2"	4.0"	5.5"	3.37"	1/2"
	(130)	(132.6)	(101.6)	(139.7)	(85.5)	NPT

\*BSP Threads or Adaptors can be supplied depending on country location.

**ADJUSTABLE AIR AMPLIFIER**

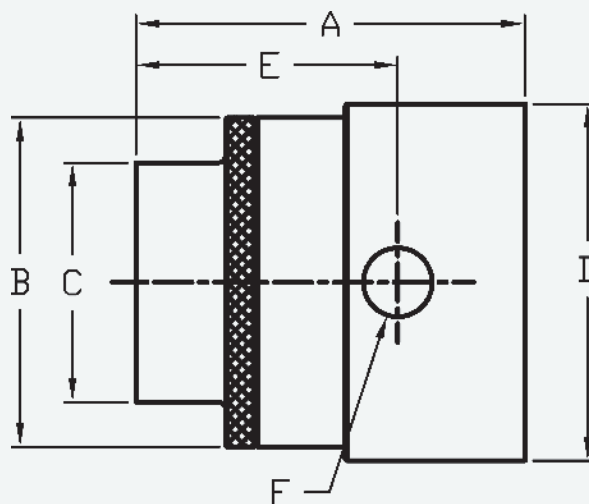

40001, 40001G and 40001S

AMPLIFICATION RATIO = 15:1 (SEE ADDENDUM - I)

**Pressure vs. Air Consumption for Model 40001, 40001G and 40001S Adjustable Air Amplifier**

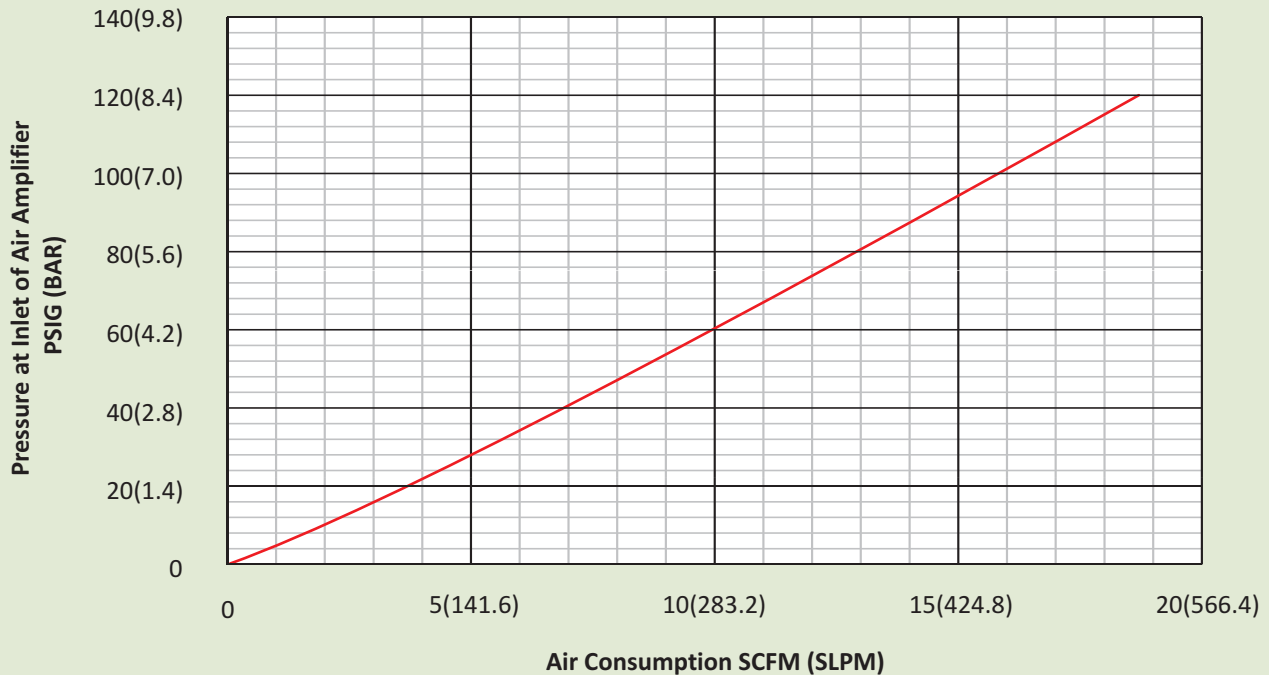

**Pressure vs. Air Flow At Outlet for Model 40001, 40001G and 40001S Adjustable Air Amplifier**

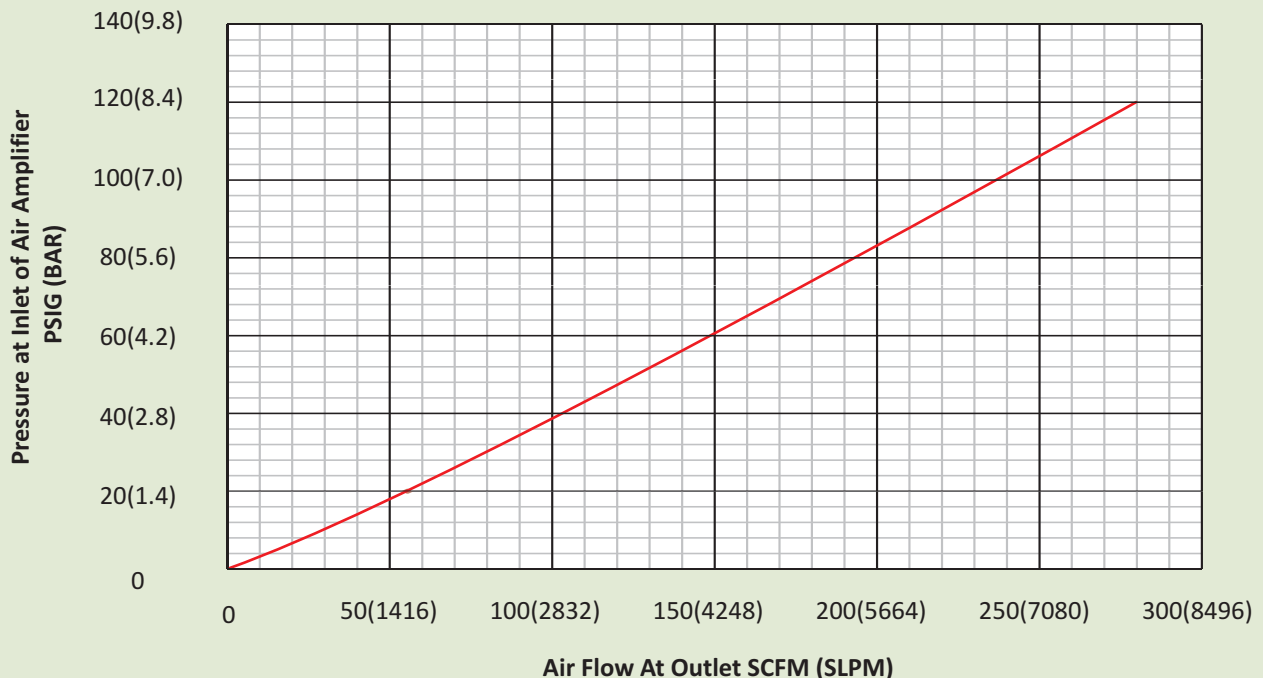

40001, 40001G and 40001S

**Pressure vs. Velocity At Outlet for Model 40001, 40001G and 40001S Adjustable Air Amplifier**

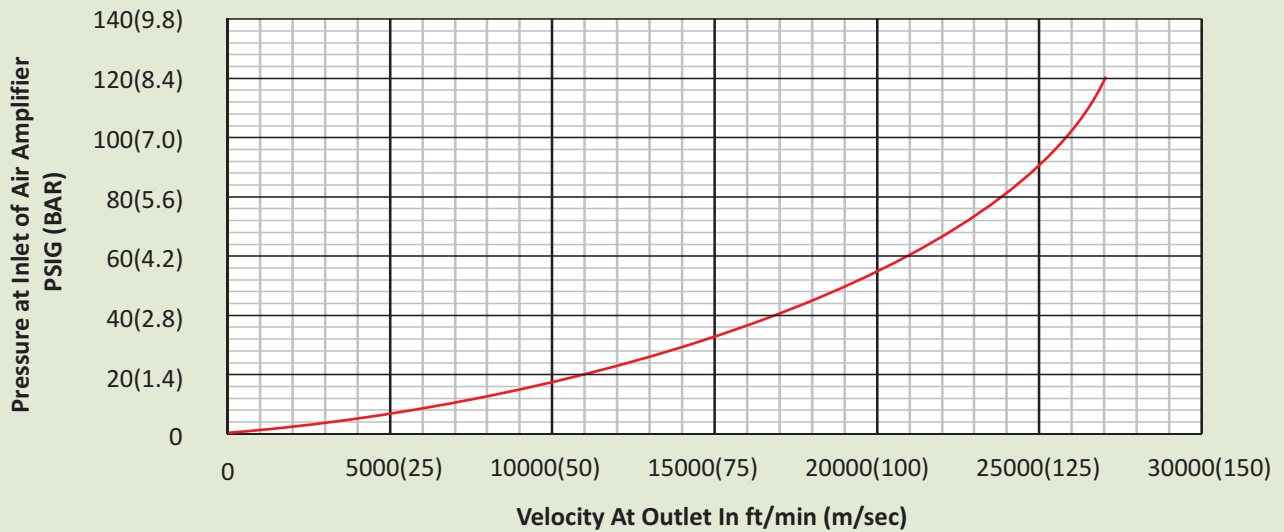

**Pressure vs. Velocity 12" From Outlet for Model 40001, 40001G and 40001S Adjustable Air Amplifier**

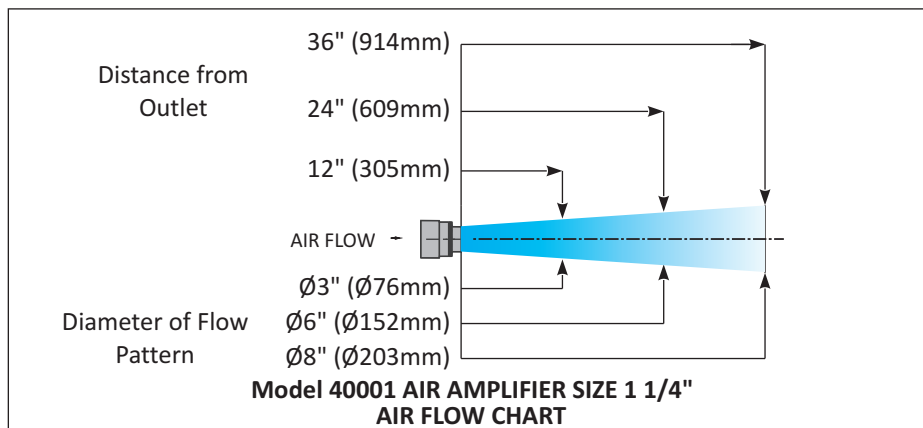

**AIR AMPLIFIERS**





40002, 40002G & 40002S

AMPLIFICATION RATIO = 16:1 (SEE ADDENDUM - I)

**Pressure vs. Air Consumption for Model 40002, 40002G & 40002S Adjustable Air Amplifier**

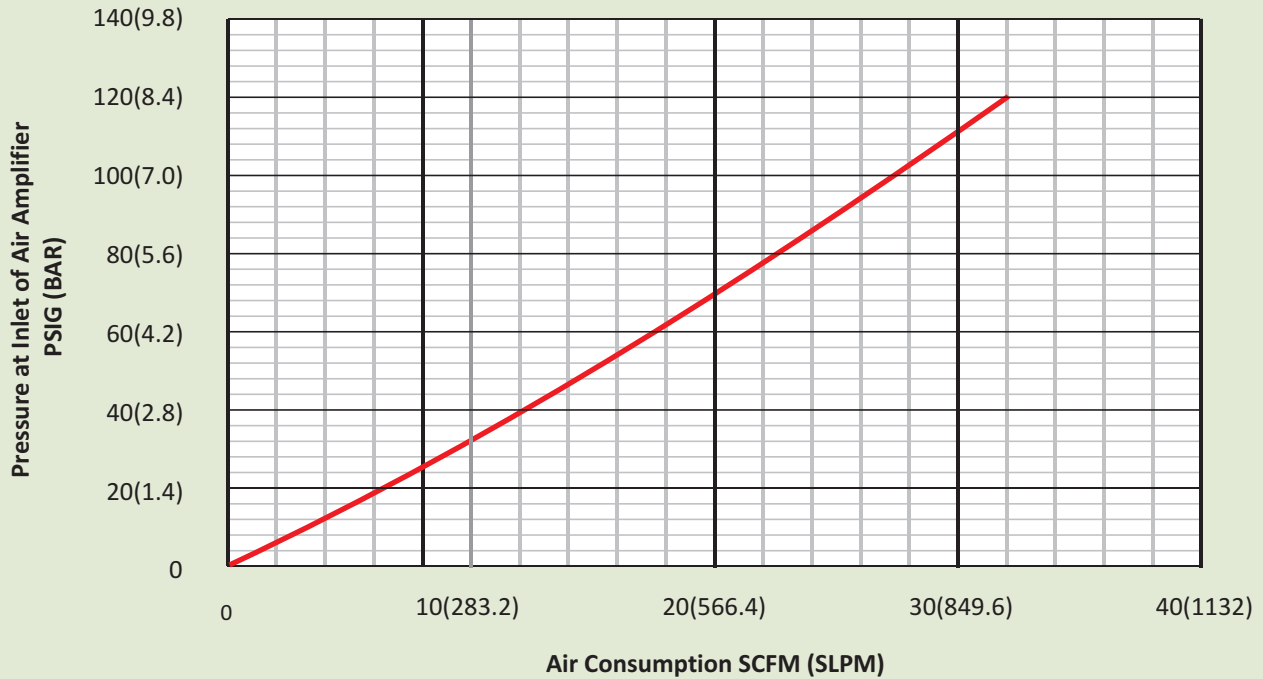

**Pressure vs. Air Flow At Outlet for Model 40002, 40002G & 40002S Adjustable Air Amplifier**

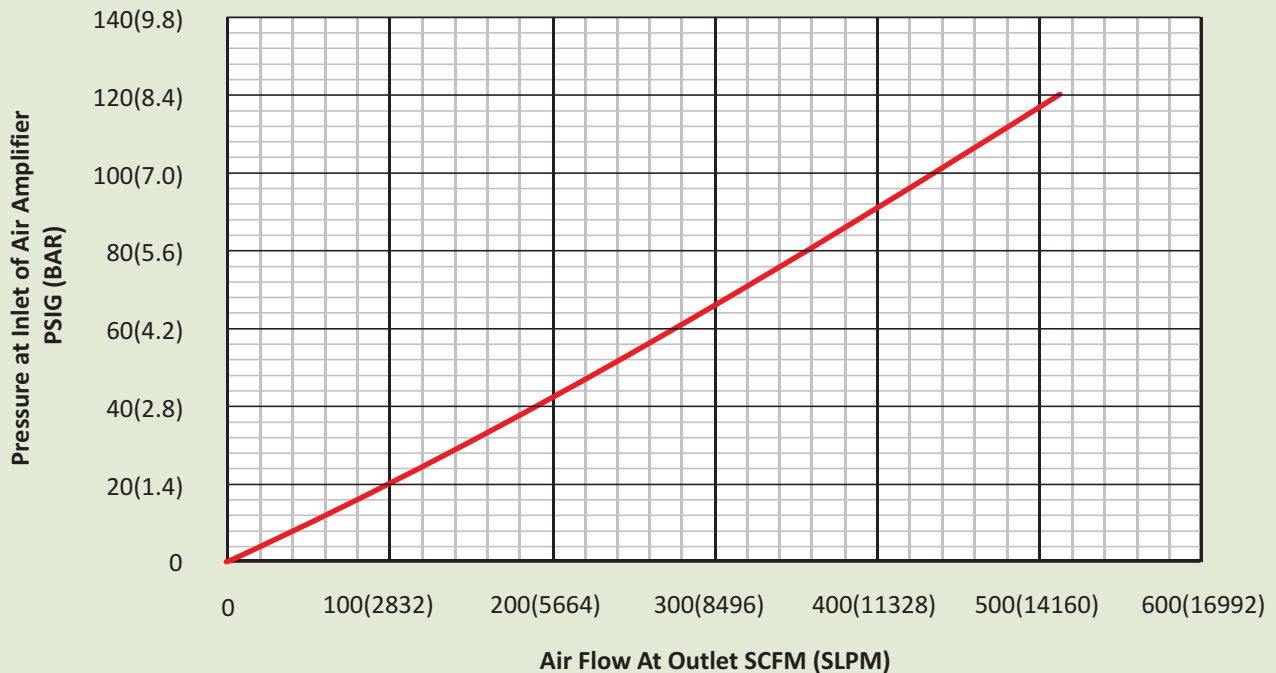

**40002, 40002G & 40002S**

**Pressure vs. Velocity At Outlet for Model 40002, 40002G & 40002S Adjustable Air Amplifier**

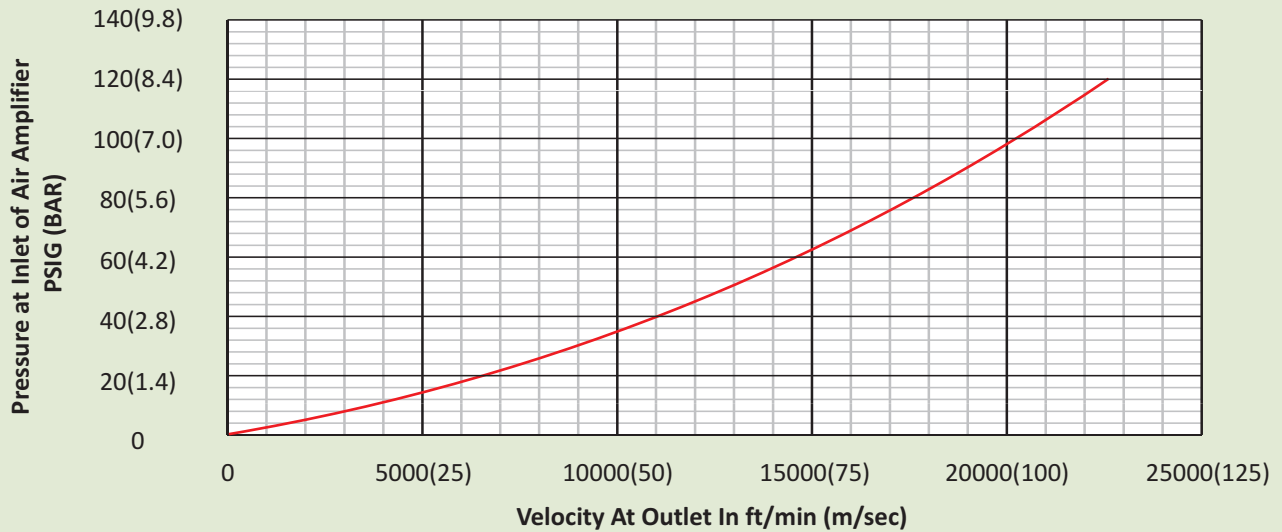

**Pressure vs. Velocity 12" From Outlet for 40002, 40002G & 40002S Adjustable Air Amplifier**

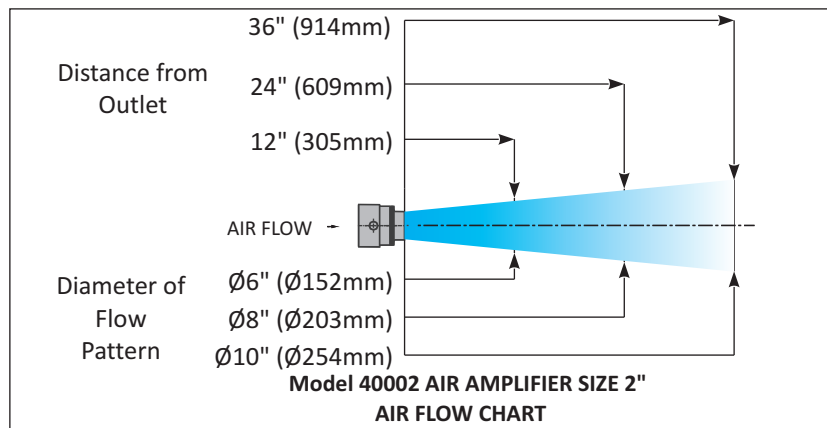
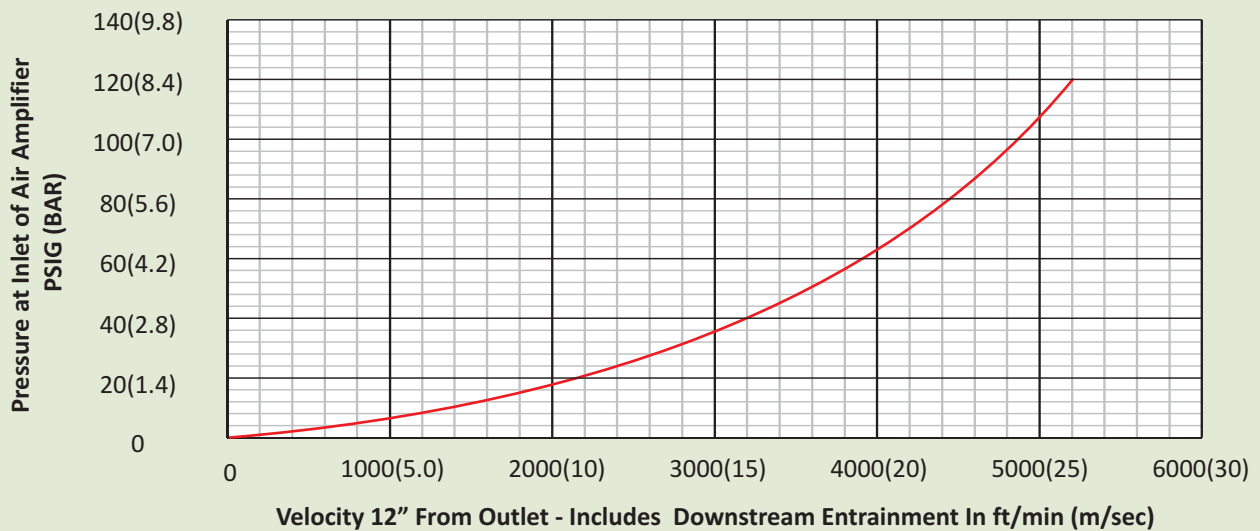

40003 & 40003S

AMPLIFICATION RATIO = 17:1 (SEE ADDENDUM - I)

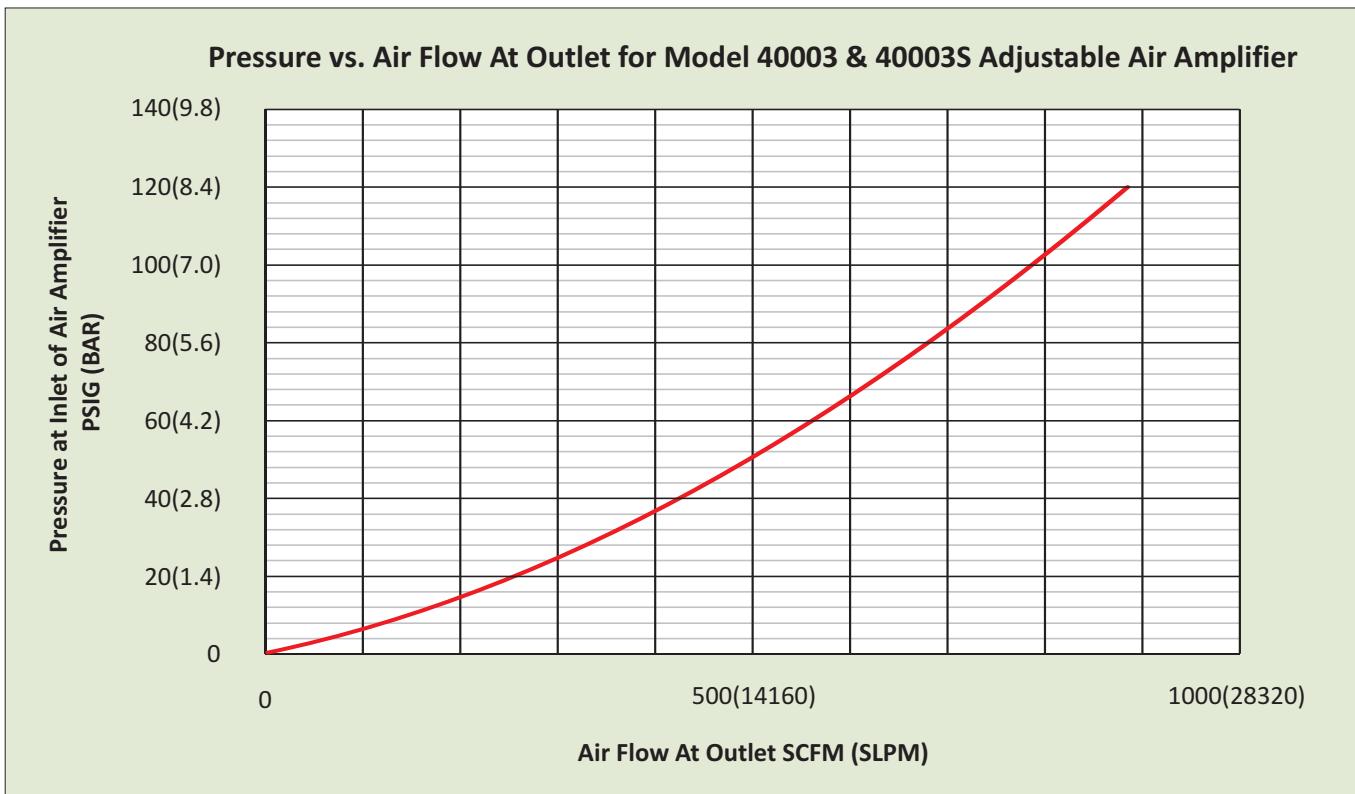
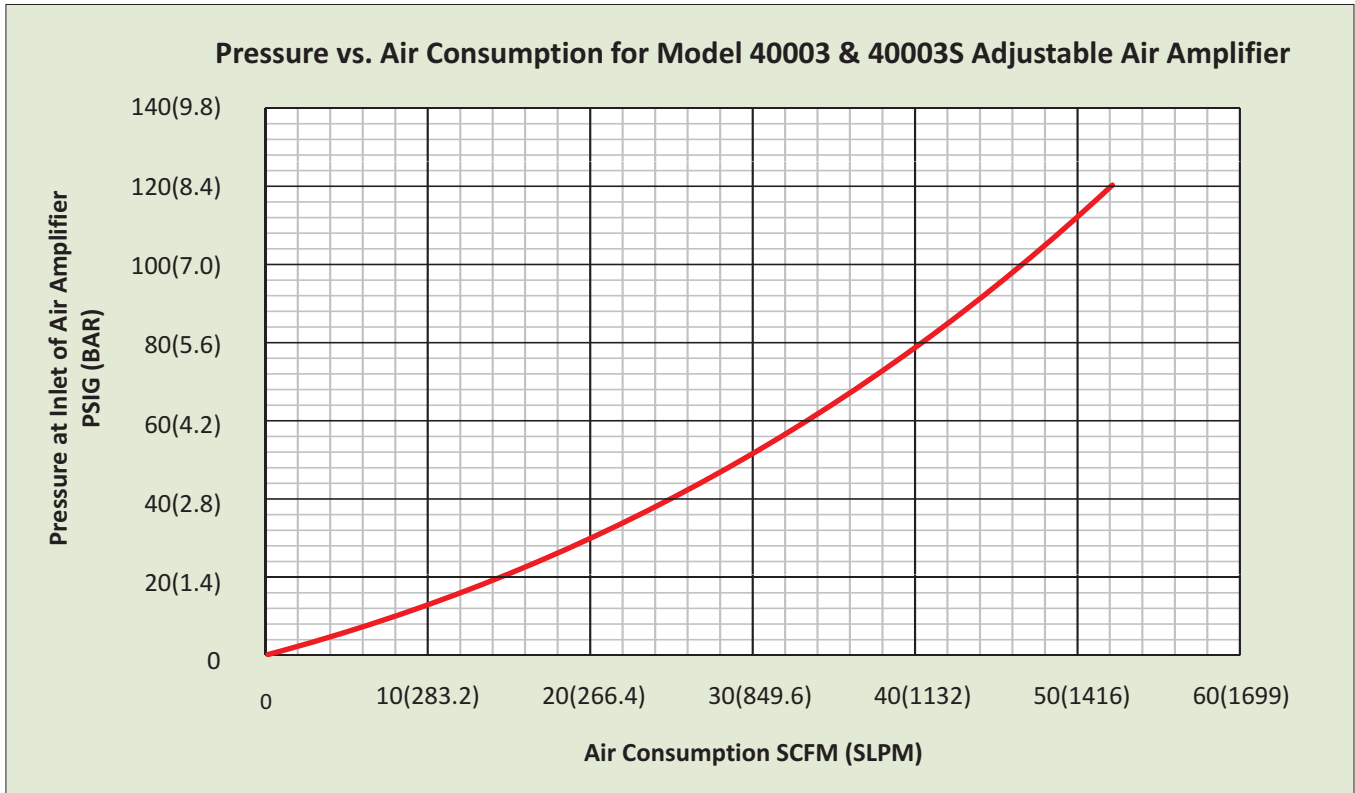

**40003 & 40003S**

**Pressure vs. Velocity At Outlet for Model 40003 & 40003S Adjustable Air Amplifier**

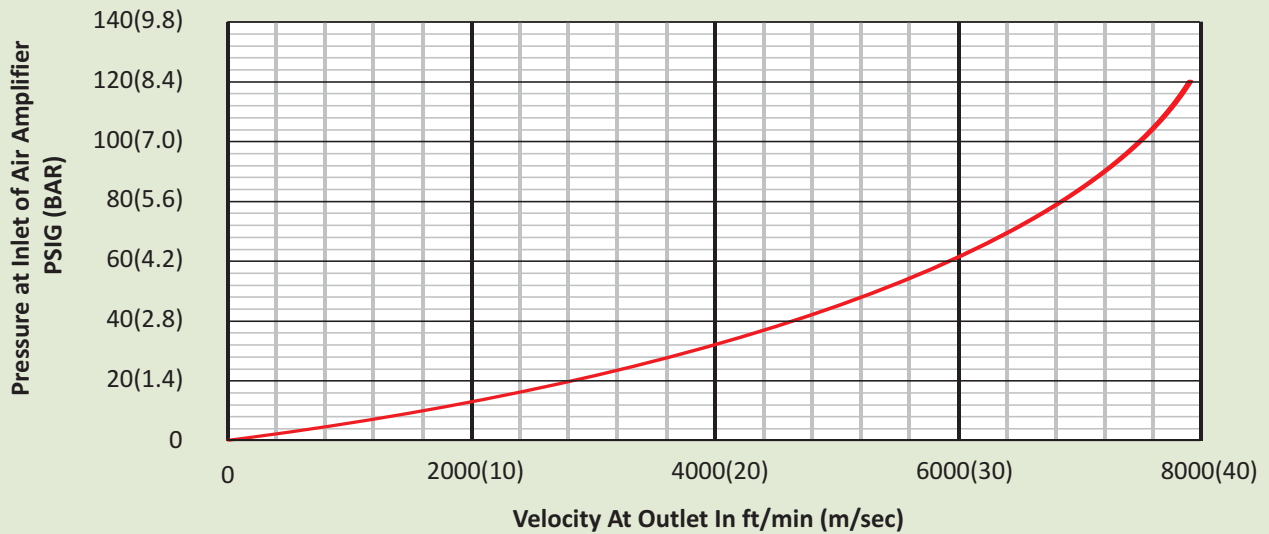

**Pressure vs. Velocity 12" From Outlet for Model 40003 & 40003S Adjustable Air Amplifier**

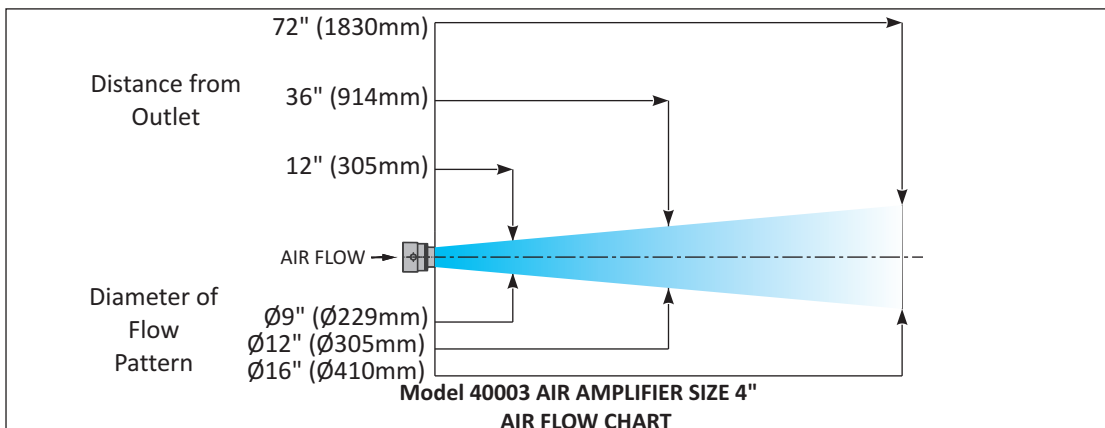
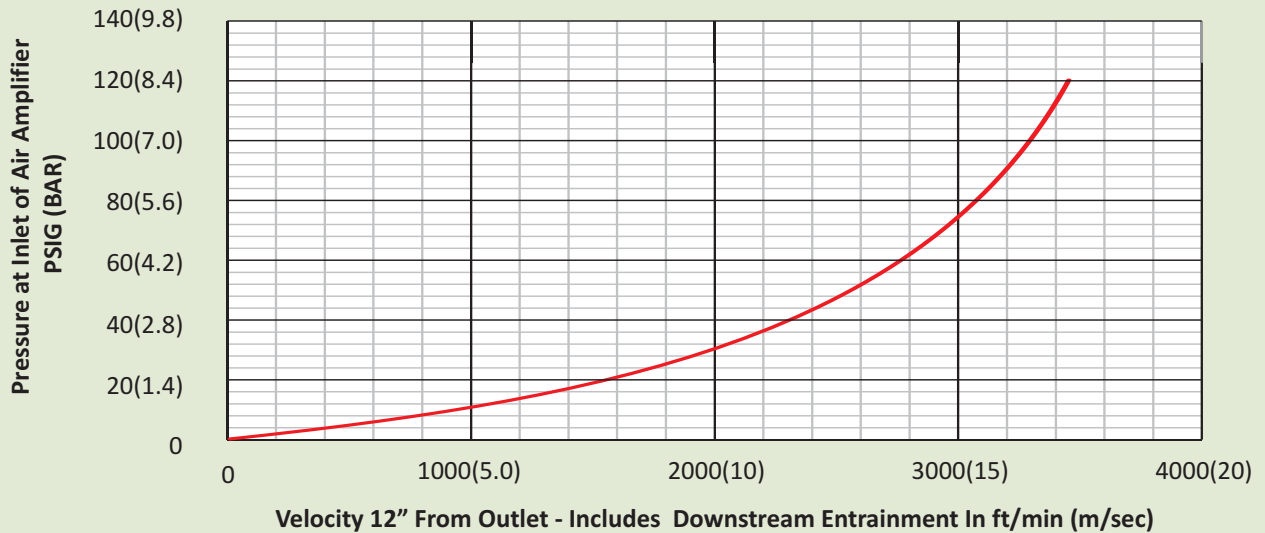

**AIR AMPLIFIERS**

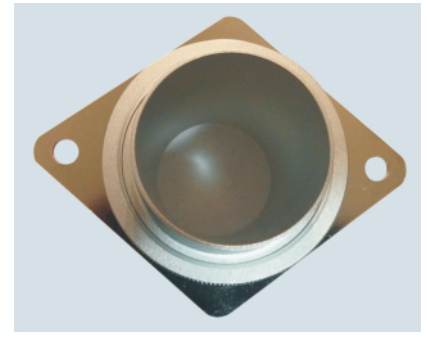
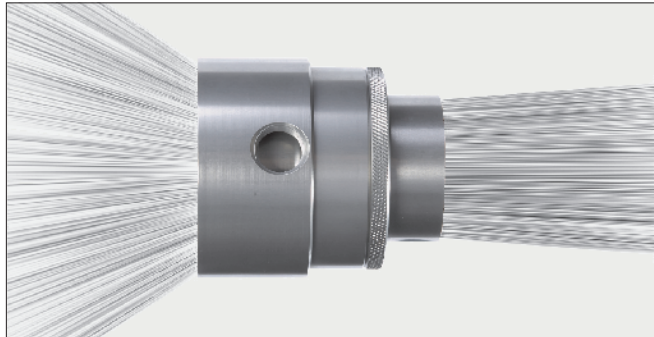
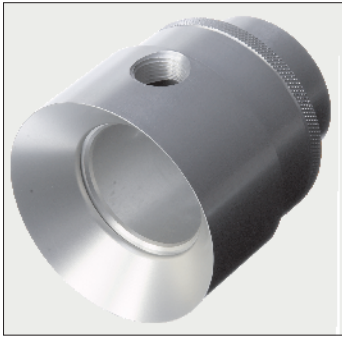

The Adjustable Air Amplifier can be adjusted to provide the blow-off force and/or vacuum required for any particular application. Made of anodized aluminum or stainless steel for corrosive and high temperature applications the unit offers flexibility in applications.

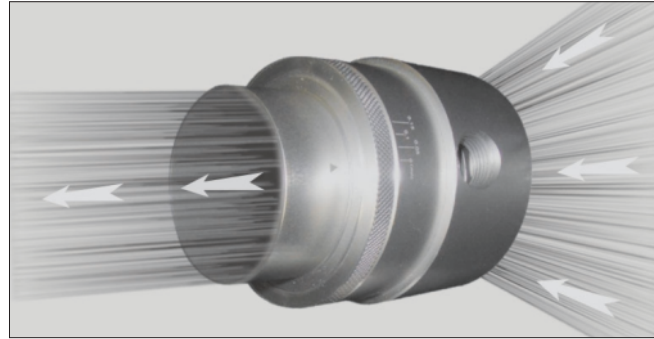
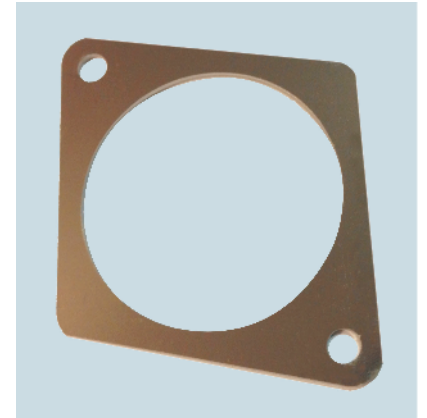

The Gauged Adjustable Air Amplifier with marking to indicate the settings from 0 to 1.5 mm comes in anodized aluminum for applications where accurate gap control is required. As with the regular adjustable unit the gap is locked into place with a lock ring.

**Adjustable Air Amplifier mounting brackets allow for easy mounting. Available for the 1-1/4" and 2" sizes. Made in Stainless Steel.**

**Model 4002S Stainless Steel Adjustable Air Amplifiers cool hot spots on a duct where insulation has worn away until downtime can be scheduled.**

**Model 40001 Adjustable Air Amplifier vents dust from a machining operation.**

## ADJUSTABLE AIR AMPLIFIERS - ALUMINUM

PART NO.	DESCRIPTION
40001	1-1/4" Adjustable Aluminum Air Amplifier
40002	2" Adjustable Aluminum Air Amplifier
40003	4" Adjustable Aluminum Air Amplifier
41001	1-1/4" Adjustable Aluminum Amplifier plus Filter with Auto Drain
41002	2" Adjustable Aluminum Amplifier plus Filter with Auto Drain
41003	4" Adjustable Aluminum Amplifier plus Filter with Auto drain
42001	1-1/4" Adjustable Aluminum Amplifier plus Filter with Auto Drain plus Regulator with Gauge
42002	2" Adjustable Aluminum Amplifier plus Filter with Auto Drain plus Regulator with Gauge
42003	4" Adjustable Aluminum Amplifier plus Filter with Auto Drain plus Regulator with Gauge

## ADJUSTABLE AIR AMPLIFIERS - GAUGED SETTINGS

PART NO.	DESCRIPTION
40001G	1-1/4" Adjustable Aluminum Air Amplifier with Gauged Settings
40002G	2" Adjustable Aluminum Air Amplifier with Gauged Settings
41001G	1-1/4" Adjustable Aluminum Air Amplifier with Gauged Settings plus Filter with Auto Drain
41002G	2" Adjustable Aluminum Air Amplifier with Gauged Settings plus Filter with Auto Drain
42001G	1-1/4" Adj. Aluminum Air Amplifier with Gauged Settings plus Filter with Auto Drain plus Regulator with Gauge
42002G	2" Adj. Aluminum Air Amplifier with Gauged Settings plus Filter with Auto Drain plus Regulator with Gauge

## ADJUSTABLE AIR AMPLIFIERS - STAINLESS STEEL

PART NO.	DESCRIPTION
40001S	1-1/4" Adjustable Stainless Steel Air Amplifier
40002S	2" Adjustable Stainless Steel Air Amplifier
40003S	4" Adjustable Stainless Steel Air Amplifier
41001S	1-1/4" Adjustable Stainless Steel Amplifier plus Filter with Auto Drain
41002S	2" Adjustable Stainless Steel Amplifier plus Filter with Auto Drain
41003S	4" Adjustable Stainless Steel Amplifier plus Filter with Auto Drain
42001S	1-1/4" Adjustable Stainless Steel Amplifier plus Filter with Auto Drain plus Regulator with Gauge
42002S	2" Adjustable Stainless Steel Amplifier plus Filter with Auto Drain plus Regulator with Gauge
42003S	4" Adjustable Aluminum Steel Amplifier plus Filter with Auto Drain plus Regulator with Gauge
40001 MTS	Mounting bracket for 40001, 40001G and 40001S
40002MTS	Mounting bracket for 40002, 40002G and 40002S



## Spray Booth Dry Air Gun System

Blowoff, clean, cool and dry as well as vent and exhaust with no moving parts

### SPRAY BOOTH DRY AIR GUN SYSTEM:

Similar to the Model: 48001 but fixed to a handle and supplied with a filter screen on the intake end, this unit is designed especially for cooling solvent and water based paint surfaces quickly and efficiently.

### SPECIFICATIONS:

- ▶ Maximum inlet pressure: 10 bar (145 psig)
- ▶ Working pressure: 3-6 bar (43-87 psig)
- ▶ Air Consumption: 12.3 cfm (350l/min) at 60 psig
- ▶ Air Inlet thread ¼" NPT



### SPRAY BOOTH DRY AIR GUN SYSTEM



#### FIXED MOUNTING SYSTEM



#### ADJUSTABLE MOUNTING SYSTEM

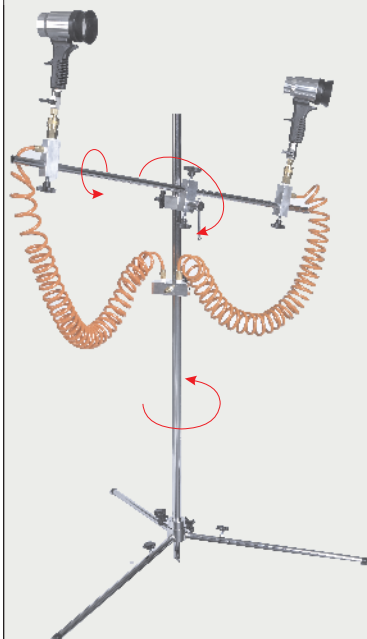

### MOUNTING SPECIFICATION

The Mounting Brackets come in two versions: Model 48002 Fixed System complete with a sturdy stand, vertical support bar, parallel support bar and two movable supports to hold the Dry Air Guns or any other blowoff product from an air knife or amplifier to jets and nozzles. The compressed air is fed in at the bottom of the support with hoses (supplied with the system) feeding the blowoff units. Model 48003 Adjustable System is the same as the above except for the adjustable parallel support bar for totally variable support adjustments to aim the blowoff units wherever they need to be. This simple design allows for tremendous portability and flexibility of use for many blowoff applications

PART NO.	DESCRIPTION
48001	Dry Air Gun Only
48002	Fixed Mounting System
48003	Flexible Mounting System
48004	Diffuser Spare Part
48005	Spare Sieve



## AIR NOZZLES AND JETS

Superior designed Air Nozzle and Jets reduce compressed air consumption and noise levels while maintaining Laminar Flow for Strong Blowoff

### WHAT ARE THEY - REASONS TO USE

Air Nozzles are the smallest air amplifiers for point applications. There are two types: and aspirator or coned shaped type and so-called star-shaped profiles. The aspirator types provide greater flow amplification, ideal for cooling but have a lower force/air consumption ratio than star-shaped versions. So when higher force is more important, the star profile versions are the best choice.

Air Jets entrain large volumes of surrounding air through the Jet (similar to air amplifiers) and are more efficient than Air Nozzles because of their larger size. The larger the “air amplification nozzle or jet” the greater the efficiency for flow amplification although larger star profile nozzles can give a higher force/air consumption ratio.

The most important reasons to use Air Amplification Nozzles and Jets apart from energy reduction is safety and reduced noise levels. All Nex Flow™ Air Nozzles and Jets meet OSHA standard CFR 1910.242 (b) for dead end pressure. Noise levels are dramatically reduced up to 10dBA along with lower energy consumption.



The Nex Flow™ Air Mag™ “patent pending” star profile air amplifying nozzle has the best force/air consumption ratio known. Ideal when higher force required in blowoff applications.

Nex Flow™ Nozzles and Jets: Our range of nozzles can address most valid applications for blowoff and cooling.

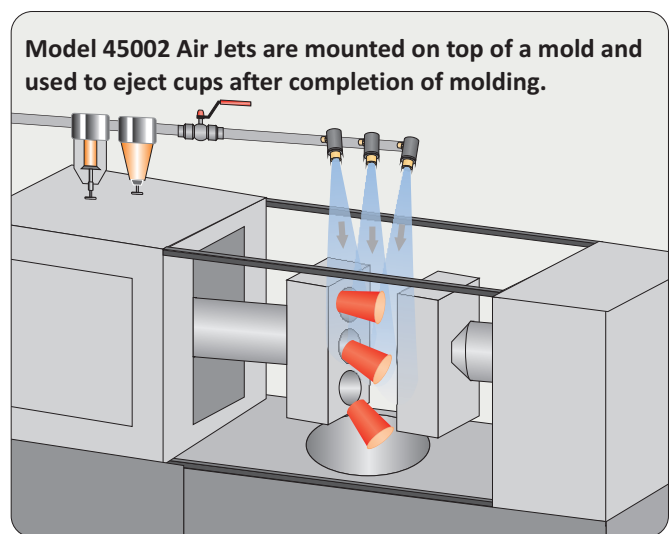
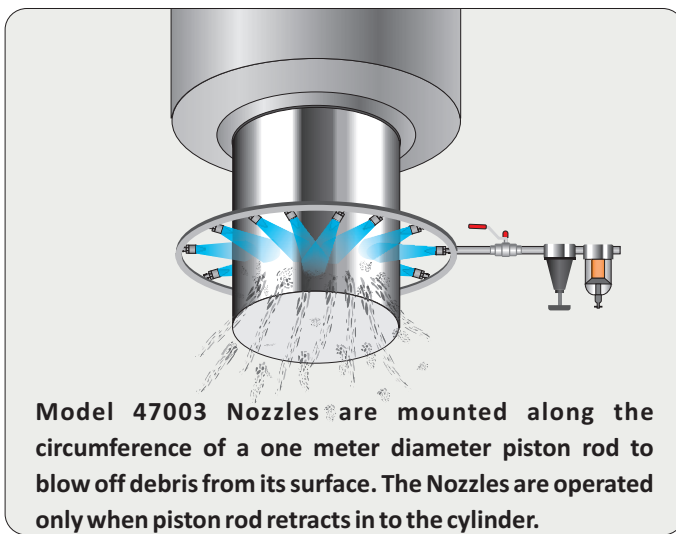



**HOW IT WORKS**

Air Mag™ Nozzle Model 47004AMF – Compressed air enters at point (A). Surrounding air (B) is entrained over the specially designed surface profile as the small amount of compressed air exits the specially designed holes drilled in the nozzle and combines at (C) to form a concentrated high velocity, laminar flow stream of amplified air flow and concentrated force with very high ratio of force/cfm.

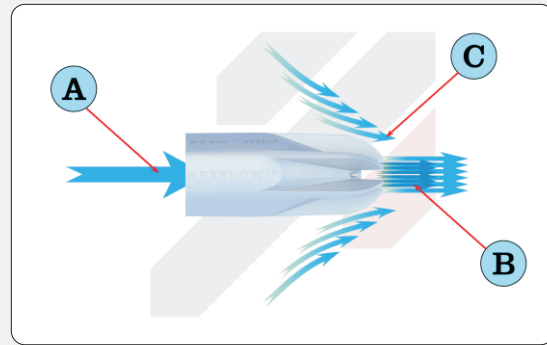

**HOW IT WORKS**

Air Nozzle - Models 47001, 47002, 47003, 47003S, 47003S-316L, 47004, 47004S, 47004S-316L, 47009, 47009S, 47009S-316L Compressed air enters at point (A). Surrounding air (B) is entrained over a specially designed profile surface by the action of the small amount of compressed air leaving the ring gap at point (C). This results in a concentrated high velocity, laminar flow stream of amplified air with maximized force.

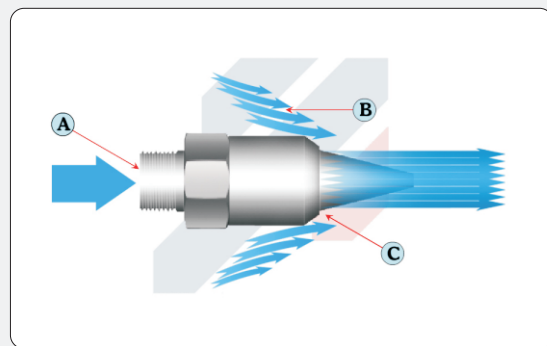

**HOW IT WORKS**

X-stream™ Air Nozzle - Model 47010 - Compressed air enters at point (A). Surrounding air (B) is entrained over a specially designed profile surface by the action of the small amount of compressed air leaving the small drilled holes at point (C). This results in a concentrated high velocity, laminar flow stream of amplified air with maximized force.

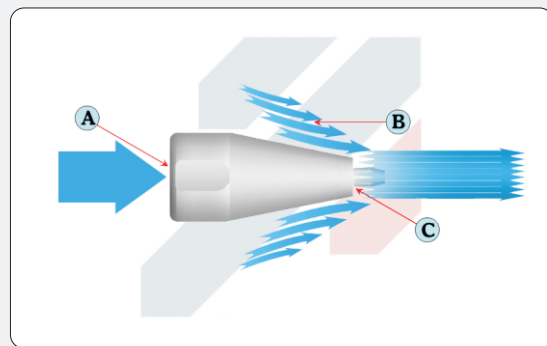

**AIR NOZZLES**

PART NO.	DESCRIPTION
47004AMF	Cast Zinc high force/air consumption efficiency Air Mag™ nozzle - ¼" female NPT or BSP
47001	Brass Mini Nozzle with 10/32 fitting or metric equivalent
47002	Brass Mini Nozzle with copper tube - male
47003	Standard Aluminum 1/8" NPT or BPS male fitting
47003S	Standard 303/304 Stainless Steel 1/8" NPT or BPS male fitting
47003S-316L	Standard 316L Stainless Steel 1/8" NPT or BPS male fitting
47004	Extra Strong Aluminum 1/4" NPT or BPS male fitting
47004S	Standard 303/304 Stainless Steel 1/4" NPT or BPS male fitting
47004S-316L	Standard 316L Stainless Steel 1/4" NPT or BPS male fitting
47009	Adjustable Aluminum Nozzle with 1/8" male NPT or BPS fitting
47009S	Standard 303/304 Stainless Steel 1/8" NPT or BPS male fitting
47009S-316L	Standard 316L Stainless Steel 1/8" NPT or BPS male fitting
47010	X-Stream™ Anodized Aluminum Strong Force Nozzle with ¼" female NPT or BPS fitting



**THE NEX FLOW™ AIR MAG™ NOZZLES**

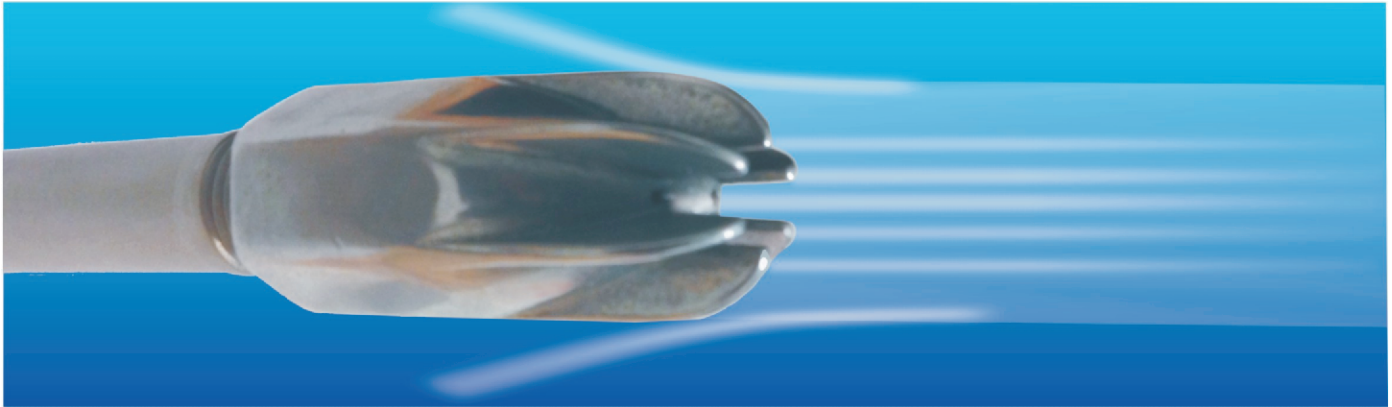

The “Patent Pending” **NEX FLOW™ AIR MAG™ NOZZLE** is extremely efficient in producing a higher force/unit of air consumption because of its unique design utilizing small diameter air exit holes to concentrate the air flow from the other holes, along with entrained air to produce a high force at the target. This design also extends the distance for laminar flow allowing greater flexibility in use at a distance. It even out performed so-called laval type nozzles and does not have the annoying whistling sound that might occur with such designs.

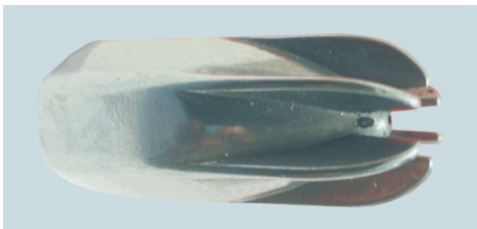

**Model 47004AMF** – is the first product of the **The Nex Flow™ Air Mag™** “patent pending” star profile air amplifying nozzle and has the best force/air consumption ratio known. Ideal when higher force required in blowoff applications.

**Sound Level 74 dBA at 3 ft. (0,91m) at 80 psig (5.5 bar)**

**HOW TO PROVE FOR YOURSELF HOW GOOD A NOZZLE IS?**

The Nex Flow™ Air Mag™ nozzle is designed so that the force at a particular pressure will be approximately the same as competitive nozzle of star type profile design. To compare and prove the superiority of the Nex Flow™ Air Mag™ nozzle this makes it easy by simply replacing the other nozzle and seeing what happens. To do this, have a pressure regulator and gauge upstream. And if possible a flow meter upstream. Either have a scale to blow against or just apply it your particular application. For each nozzle, adjust the pressure upstream to that it is the same for all nozzles tested. This is what you can expect.....

If you replace any competitive nozzle, you will probably have to cut back the pressure as you will get more force from the Nex Flow™ Air Mag™ nozzle. This is because the air consumption is “less” at any given pressure which also means less pressure drop in the line as the air flows out through the nozzle. So you will actually be getting a bit more pressure and force as a result. You can then cut back the pressure if not needed thereby reducing compressed air use even more.

If you have a flow meter, all nozzles can be tested comparatively.

Alternatively, you can just try the various nozzles and you will find the Nex Flow™ Air Mag™ nozzle to perform better simply because there is less pressure drop since it uses less compressed air, indicating its greater efficiency.



**PERFORMANCE OF THE NEX FLOW™ MODEL 47004AMF AIR MAG™ NOZZLE**

AIR MAG NOZZLE - 1/4" - MODEL: 47004AMF						
<b>INLET PRESSURE PSIG (BAR)</b>	<b>20 (1.4)</b>	<b>40 (2.8)</b>	<b>60 (4.1)</b>	<b>80 (5.5)</b>	<b>100 (6.9)</b>	<b>120 (8.3)</b>
<b>FORCE LBS (GRAMS)</b>	<b>0.247 (112)</b>	<b>0.474 (215)</b>	<b>0.705 (320)</b>	<b>0.937 (425)</b>	<b>1.172 (532)</b>	<b>1.143 (519)</b>
<b>AIR CONSUMPTION SCFM (SLPM)</b>	<b>5.5 (156)</b>	<b>9.0 (255)</b>	<b>12.0 (340)</b>	<b>15.5 (439)</b>	<b>19.7 (558)</b>	<b>23.4 (663)</b>

Note: Data for Force measured at 6"

**FORCE EFFICIENCY OF THE NEX FLOW™  
MODEL 47004AMF AIR MAG™ NOZZLE  
TO COMPETITIVE VERSIONS**

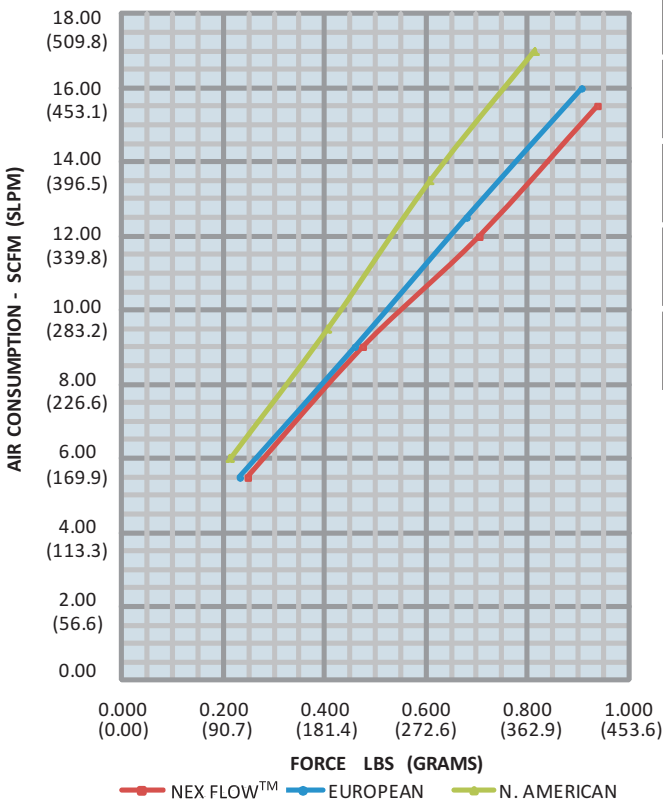

INPUT LINE PRESSURE PSIG (BAR)	NEX FLOW™ AIR MAG™ NOZZLE		EUROPEAN STAR TYPE DESIGN		NORTH AMERICAN STAR TYPE DESIGN	
	Force-Lbs (Force-gms)	SCFM (SLPM)	Force-Lbs (Force-gms)	SCFM (SLPM)	Force-Lbs (Force-gms)	SCFM (SLPM)
40 (2.8)	.474 (215)	9.0 (255)	.421 (191)	9.0 (255)	.421 (191)	9.5 (269)
60 (4.1)	.705 (320)	12.0 (340)	.637 (289)	12.5 (354)	.633 (287)	13.5 (382)
80 (5.5)	.937 (425)	15.5 (439)	.840 (381)	16.0 (453)	.840 (381)	17.0 (481)

Note: Data for Force measured at 6"

**ADVANTAGES OF THE AIR MAG™ DESIGN**

- . Lowest air consumption for force produced
- . lower noise levels
- . no whistling sound
- . single piece design for extra strength



Note: Data for Force measured at 6". Data measurement was done at a college test laboratory utilizing accurate force and flow measurement equipment. All nozzles tested under the same conditions. Published data was not used – only actual measurements made in the lab.

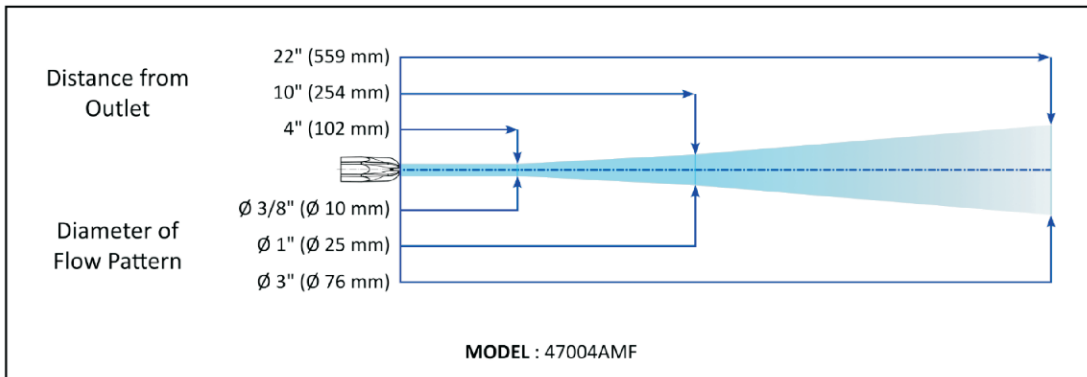

## AIR NOZZLES:

Nex Flow™ Nozzles are designed to fit into small spaces. We have an adjustable Nozzle for some applications and then a few different Nozzles with varying force, depending on the application.

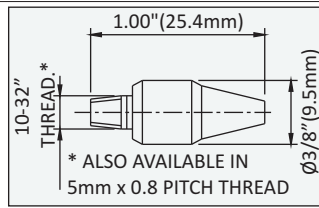
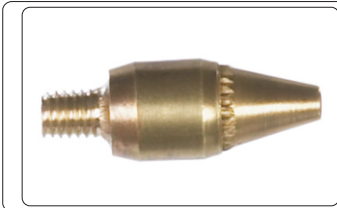

**Model 47001** - Is a small brass Nozzle to fit into small spots and used by many machine builders for blowoff applications.  
Sound level 74 dBA at 3ft (0.91mm) at 80 psig (5.6 bar).

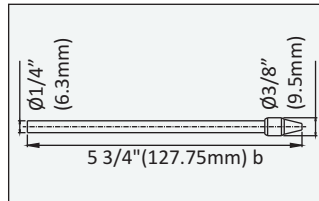

**Model 47002** - Is the small Model 47001 brass Nozzle added to a copper tube. Machine builders can bend the copper tube and aim the nozzles to where ever it suits. The copper tube is simply press fit into the customer's system.  
Sound level 74 dBA at 3ft (0.91mm) at 80 psig (5.6 bar).

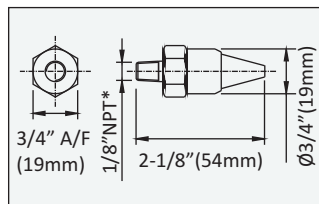

**Model 47003 (anodized aluminum), 47003S (303/304 stainless steel), 47003S-316L (316L stainless steel)** -

Is a common standard strength nozzle with a 1/8" male NPT connection and ideal for most blow-off applications involving liquids. It is made of aluminum (or stainless steel) and is partially anodized for longer life. The coanda profile is made for excellent noise reduction and blow-off force at a good distance  
Sound level 77 dBA at 3ft (0.91mm) at 80 psig (5.6 bar).

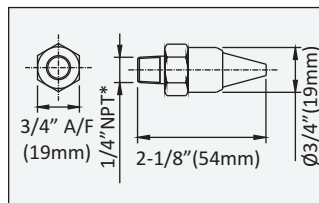

**Model 47004 (anodized aluminum), 47004S (303/304 stainless steel), 47004S-316L (316L stainless steel)** -

Is another common but stronger force nozzles with a 1/4" male NPT connection and ideal for most blow-off applications involving liquids and even light weight parts. It is made of aluminum (or stainless steel) and is partially anodized for longer life. Again the coanda profile is made for excellent noise reduction and blow-off force at a good distance.  
Sound level 78 dBA at 3ft (0.91mm) at 80 psig (5.6 bar).

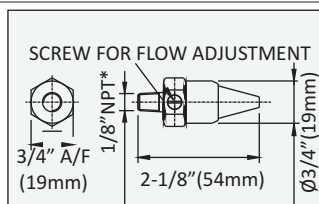
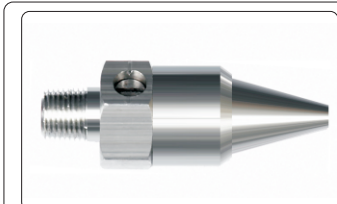

**Model 47009 (anodized aluminum), 47009S (303/304 stainless steel), 47009S-316L (316L stainless steel)** -

Is similar to the 47003 except it is made adjustable. The Superior design of the adjustable set screw is made to adjust the nozzles within its weakest and strongest ranges.

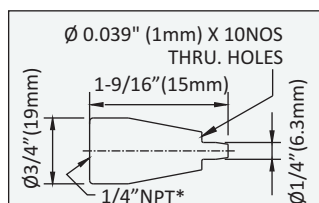
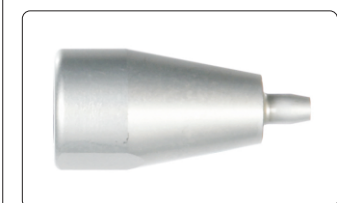

**Model 47010** - Is a unique design by Nex Flow™ and is extremely powerful. It has a 1/4" female NPT fitting and is fully anodized for long life. With the 'coanda' profile you get an extremely strong force at a distance. This is an ideal Nozzle for blow guns and for blowing small parts for part ejection heavier viscosity liquids. The 47010 is a higher force Nozzle but has less distance for laminar flow than the 47004. Use the Model 47004 is greater distance required from the Nozzle.

Sound level 78 dBA at 3ft (0.91mm) at 80 psig (5.6 bar).

\*BSP Threads or Adaptors can be supplied depending on country location.

**Air Consumption At Various Pressure for Model 47001 and 47002 Air Nozzles**

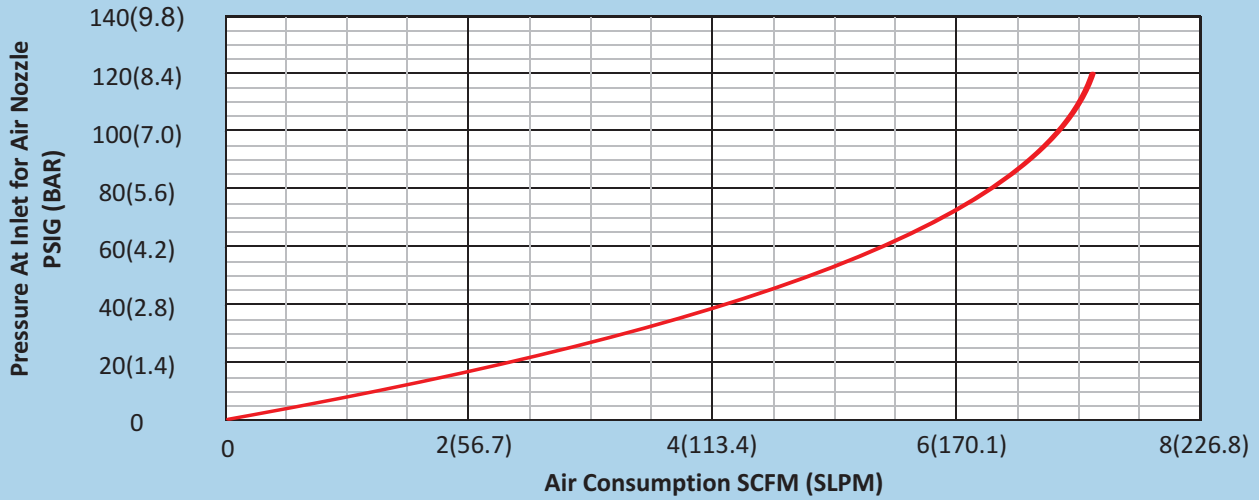

**Force At Various Pressure for Model 47001 and 47002 Air Nozzles**

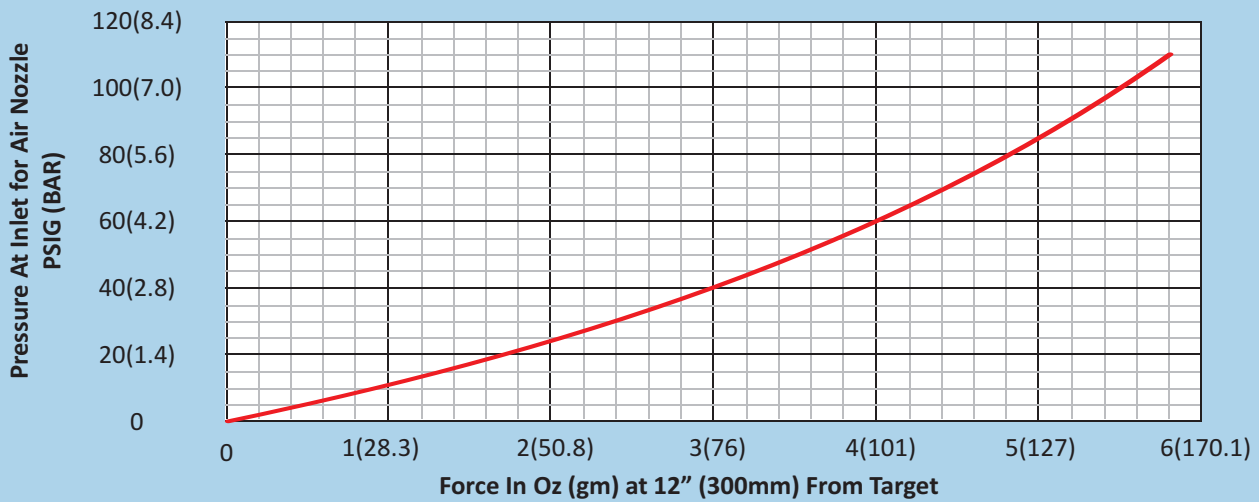

**Air Consumption At Various Pressure for Model 47003, 47003S and 47003S-316L Air Nozzles.**

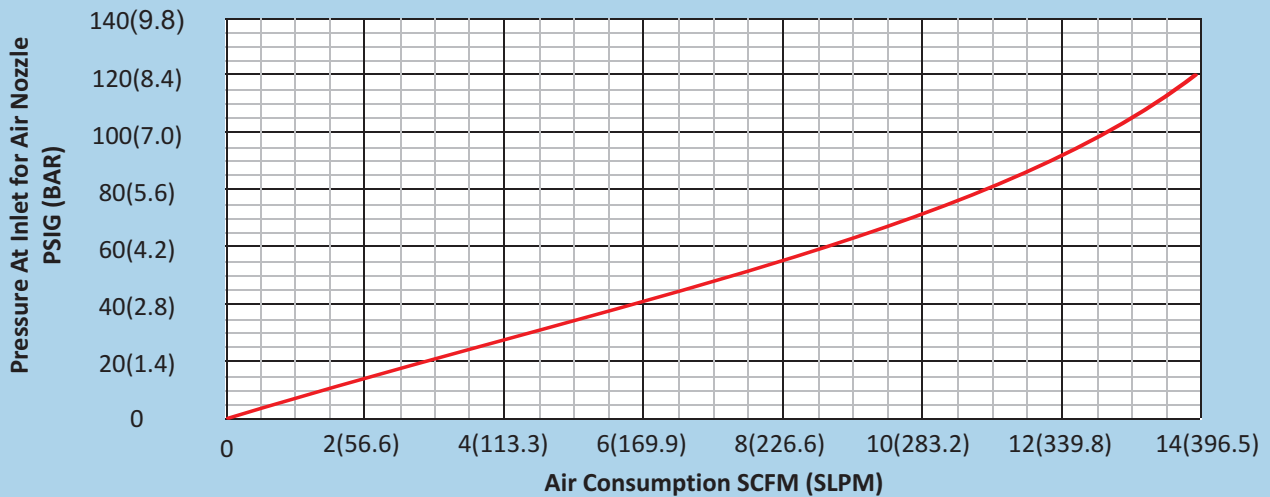

**Force At Various Pressure for Model 47003, 47003S and 47003S-316L Air Nozzles.**

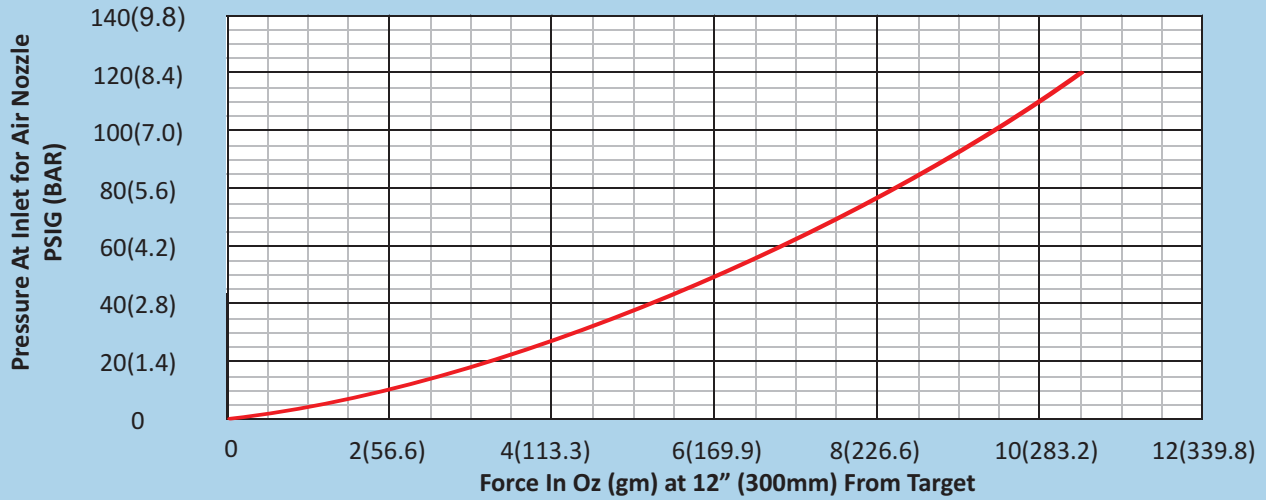

**Air Consumption At Various Pressure for Model 47003, 47003S and 47003S-316L Air Nozzles.**

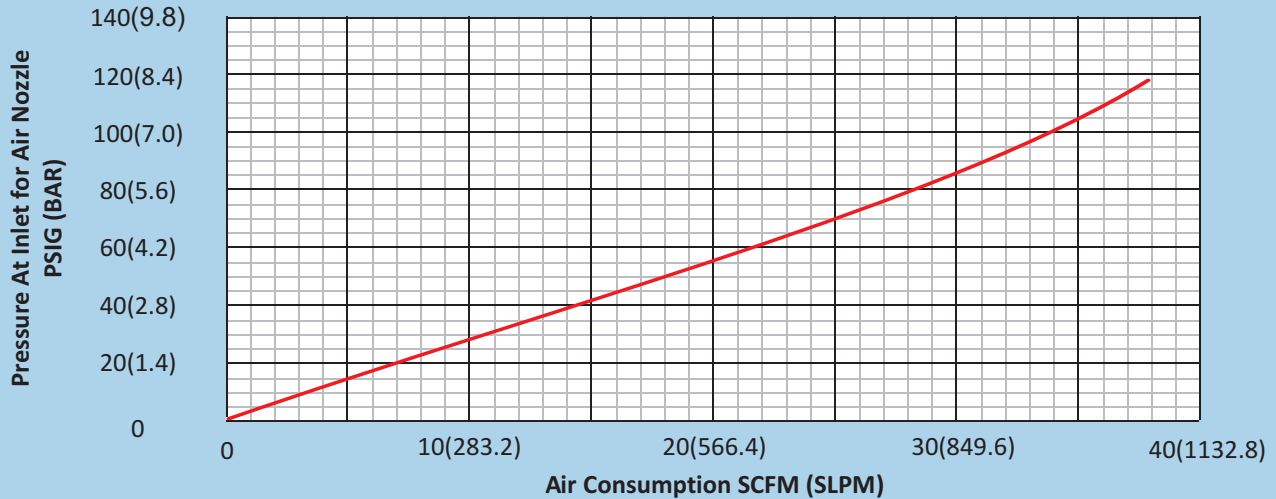

**Force At Various Pressure for Model 47004, 47004S and 47004S-316L Air Nozzles.**

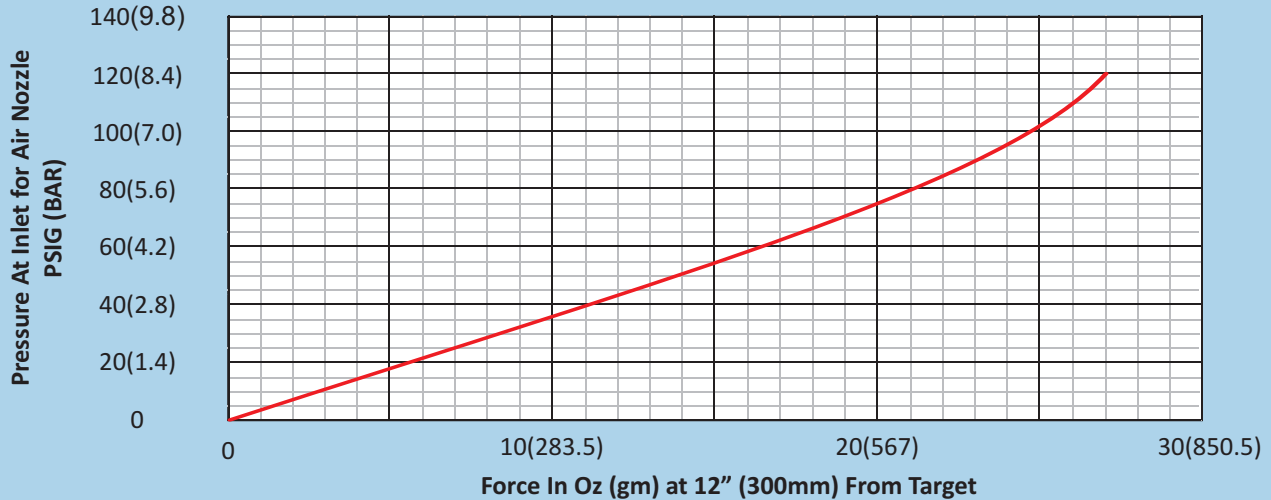

**Air Consumption At Various Pressure for Model 47009, 47009S and 47009S-316L (Max Open condition)**

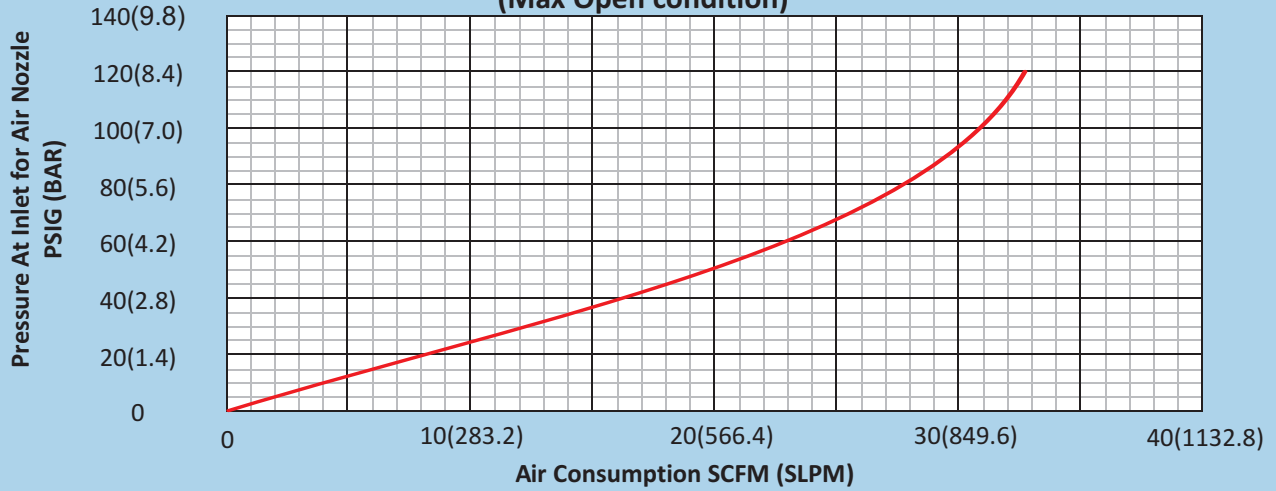

**Force At Various Pressure for Model 47009, 47009S and 47009S-316L (Max Open condition)**

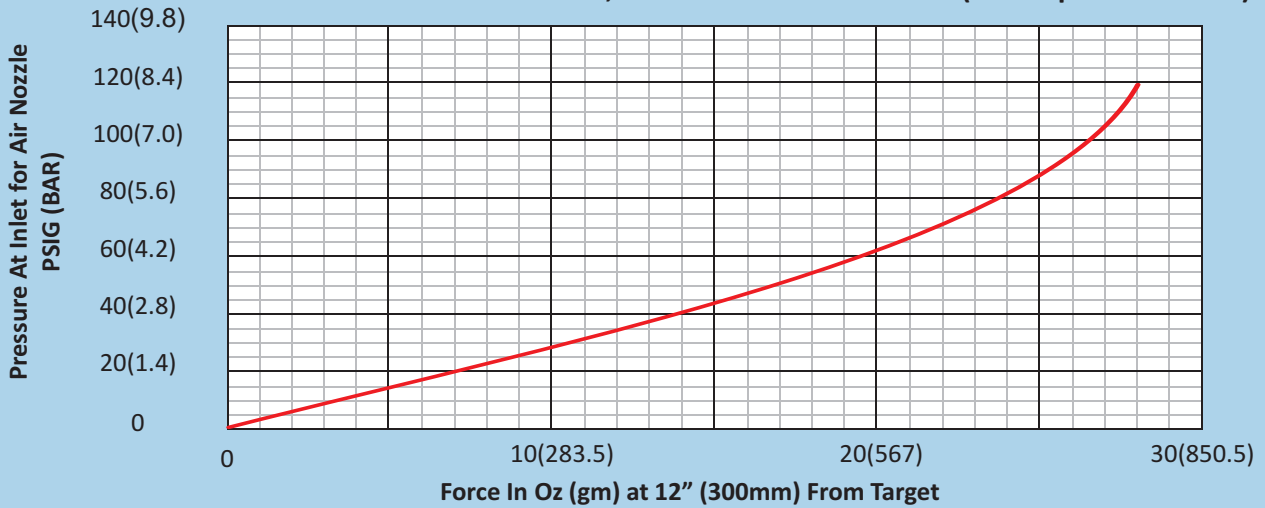

**Air Consumption At Various Pressure for Model 47010 (10 Holes)**

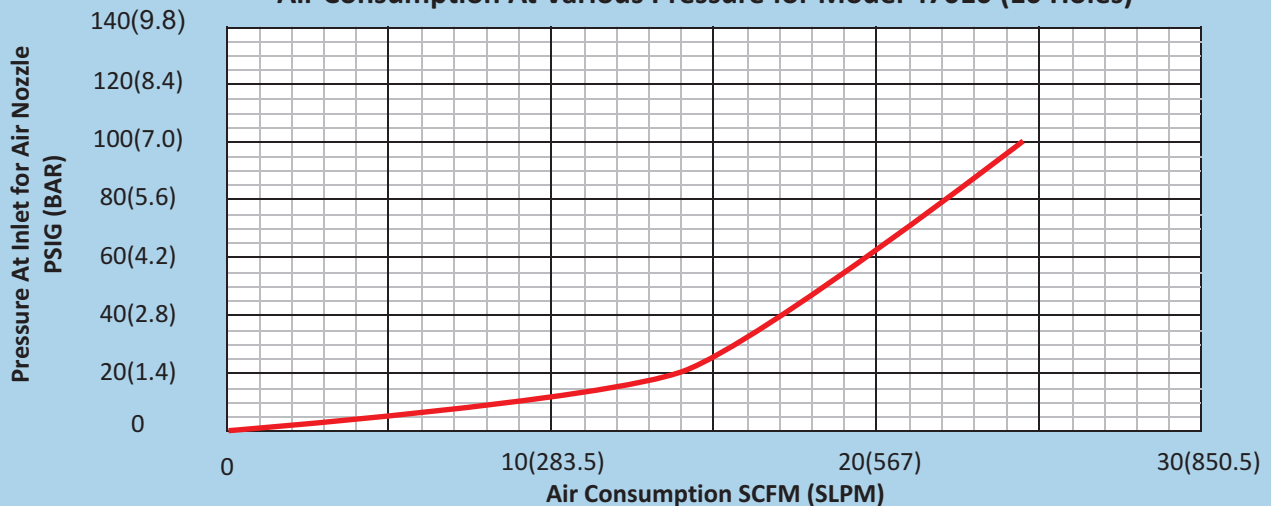

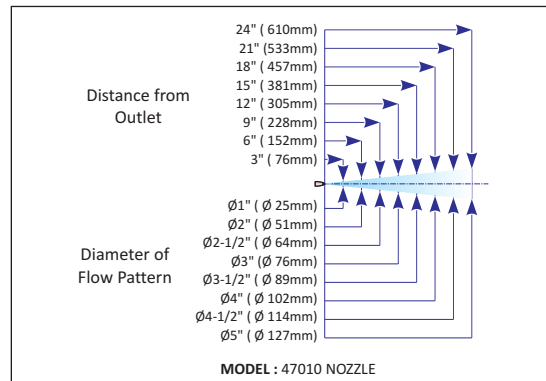
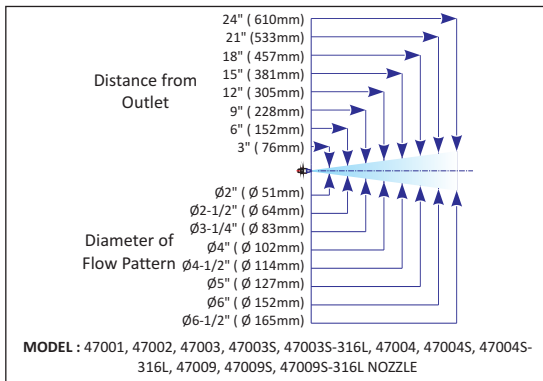
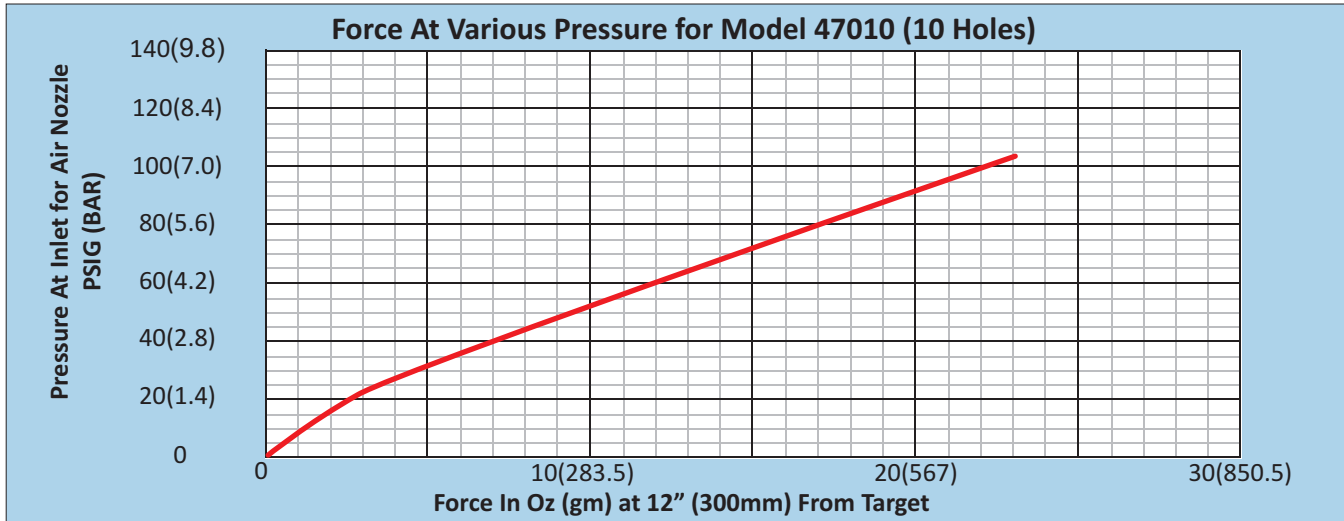

**AIR NOZZLES**

PART NO.	DESCRIPTION
47004AMF	Cast Zinc high force/air efficiency Air Mag™ nozzle - 1/4" female NPT or BPS
47001	Brass Mini Nozzle with 10/32 fitting or metric equivalent
47002	Brass Mini Nozzle with copper tube - male
47003	Standard Aluminum 1/8" NPT or BPS male fitting
47003S	Standard 303/304 Stainless Steel 1/8" NPT or BPS male fitting
47003S-316L	Standard 316L Stainless Steel 1/8" NPT or BPS male fitting
47004	Extra Strong Aluminum 1/4" NPT or BPS male fitting
47004S	Standard 303/304 Stainless Steel 1/4" NPT or BPS male fitting
47004S-316L	Standard 316L Stainless Steel 1/4" NPT or BPS male fitting
47009	Adjustable Aluminum Nozzle with 1/8" male NPT or BPS fitting
47009S	Standard 303/304 Stainless Steel 1/8" NPT or BPS male fitting
47009S-316L	Standard 316L Stainless Steel 1/8" NPT or BPS male fitting
47010	X-Stream™ Anodized Aluminum Strong Force Nozzle with 1/4" female NPT or BPS fitting

**STAINLESS STEEL RIGID FLEX HOSE ( REFER TO PAGE E9 FOR THE RIGID FLEX HOSE )**

PART NO.	DESCRIPTION
6RF (MM / MF)	6" Stainless Steel Rigid Hose which can be flexed to a shape
12RF (MM / MF)	12" Stainless Steel Rigid Hose which can be flexed to a shape
18RF (MM / MF)	18" Stainless Steel Rigid Hose which can be flexed to a shape



**AIR JETS:**

Air Jets are larger than Nozzles and used when a wider area needs to be hit with the amplified air. They are significantly more efficient than Nozzles although often use as much compressed air. Their best use is to replace pairs of Nozzles that are used for part ejection or for blowoff applications that require greater force than that provided by Air Knives or Air Movers. Nozzles are for point use while air jets can fan out somewhat for better continuous blowoff when a row of them are made. Nex Flow™ Jets are all made adjustable with a lock ring to assure the security of any gap setting. They have a female 1/8" NPT and made lightweight with anodized aluminum.

**6 models are available:** From left to right is Model 45001 High Flow Air Jet, Model 45002 High Force Air Jet and Model 45003 Mini Air Jet all in anodized aluminum, the Model 45002B High Force Air Jet in brass and the Model 45002S High Force Air Jet in 316L Stainless Steel and the Model 45004 High Force Fat Air Jet Amplifier in anodized aluminum.



The **Mini Air Jet Model 45003** is ideal for small spots where a Nozzle may not be adequate for wider coverage of air flow. It is most compact air jet available with high force and adjustability. Sound level is 82 dBA at 3ft (0.91mm) at 80 psig (5.6 bar).

<p><b>High Flow Air Jet Model 45001</b></p>	<p><b>High Force Air Jet Model 45002, Model 45002B &amp; Model 45002S</b></p>	<p><b>Model 45001 / 45002 / 45002B / 45002S</b> - High Flow Air Jet are physically the same size. The only difference is a larger exit opening for the amplified air flow. The high flow system is used more for cooling and light blowoff while the high force version is used mainly for heavier blowoff applications.</p> <p>The Sound level for Model 45001 is 80 dBA and for the Model 45002/ 45002B / 45002S it is 82 dBA at 3ft (0.91mm) at 80 psig (5.6 bar).</p> <p>The 45002B Brass Air Jet and the 45002S 316L Stainless Steel Air jet are marked to indicate the size of the air gap and can be easily set and locked into place.</p> <p>*BSP Thread or adaptors can be supplied depending on country location.</p>
<p><b>Mini Air Jet Model 45003</b></p>	<p><b>High Force Air Jet Model 45004</b></p>	

Air Jets perform similar to Adjustable Air Amplifiers - with the same lock ring and methodology. Nex Flow™ Air Jets are adjustable and come with a lock ring to fix the gap.

**HOW IT WORKS**

**Model 45001, 45002, 45002B, 45002S, 45003 and 45004** Air Jets use a small amount of compressed air entering the annular chamber and exit via small ring nozzle at high speed over a "coanda" profile. This creates a vacuum entraining outside air converting the pressure to a high flow output while maintaining a high blowoff force. Energy cost and noise levels are reduced as a result.



The **LARGE FAT Air Jet Air Amplifier** is the largest fat jet/smallest air amplifier with the same design as the high performance air jets to give you the most optimal performance with an adjustable gap and lock ring to set the gap in place.

**WHAT THEY ARE – REASONS TO USE**

*Nex Flow™* **FAT Air Jet Air Amplifier** is made of anodized aluminum and with a fine thread for a fine and accurate adjustment of the air gap to the setting desired for any particular application.

The *Nex Flow™* **FAT Air Jet Air Amplifier** is a transition size in between an air jet and the larger air amplifiers. It provides for superior air flow amplification and high force for blow off and cooling applications.

**AIR NOZZLES AND JETS**

**RIGID FLEX HOSE NOZZLE ACCESSORIES - TO HOLD AND AIM NOZZLES AND JETS**

The unique *Nex Flow™* **RIGID FLEX** hose is an all stainless steel hose that does not break after a few bends like competitive rubber hoses with simple copper inserts. It is resistant to creep and crimping. Its all stainless construction allows it use in any difficult environment. They have 1/4" male NPT welded end connections and come in 6", 12" and 18" overall lengths.



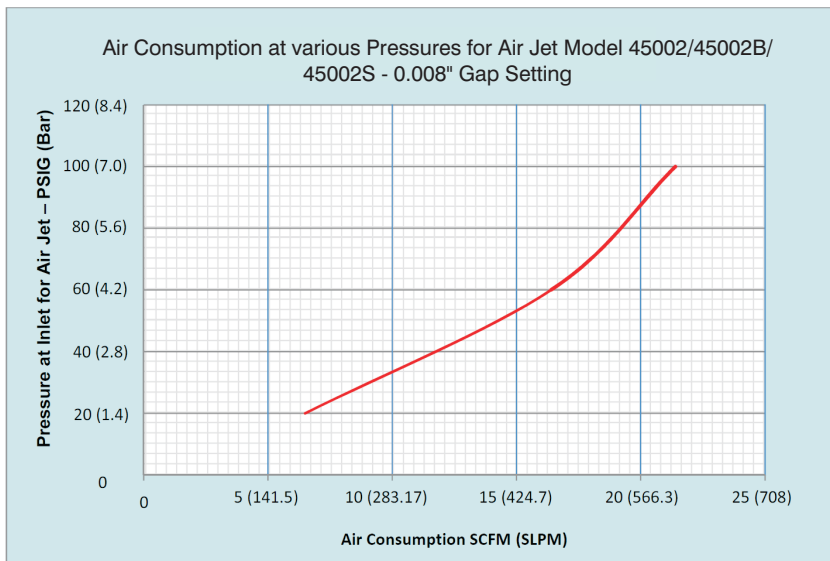
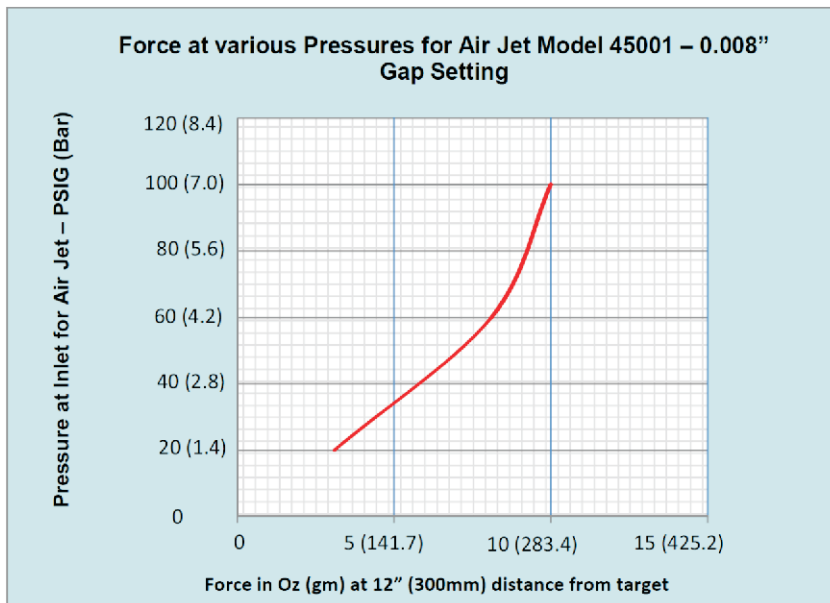
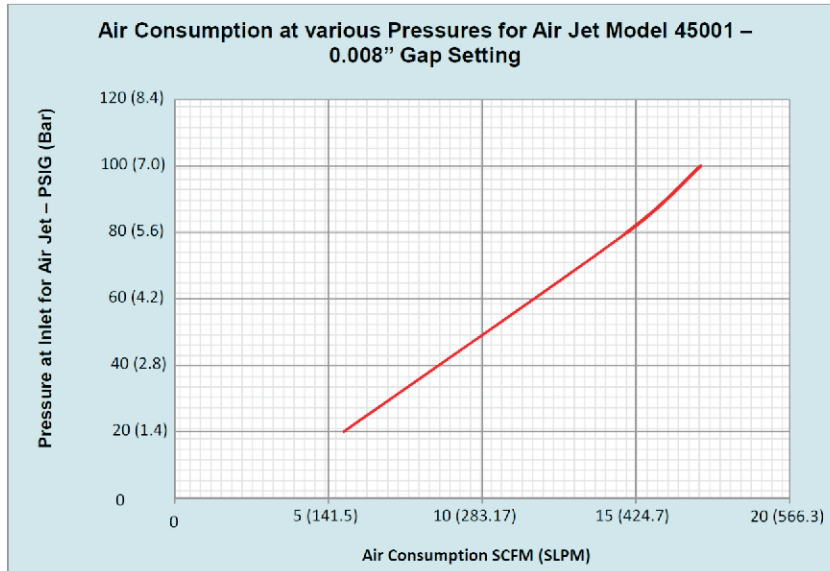

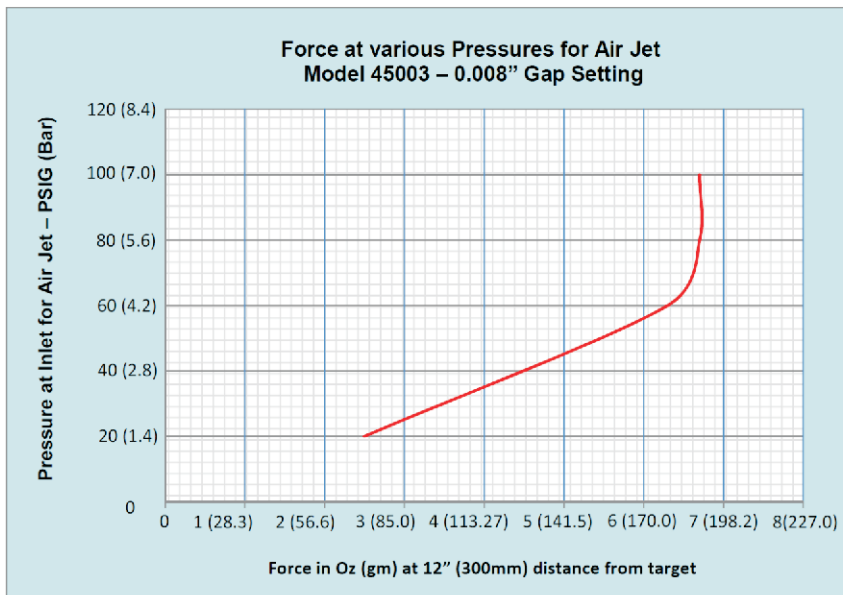
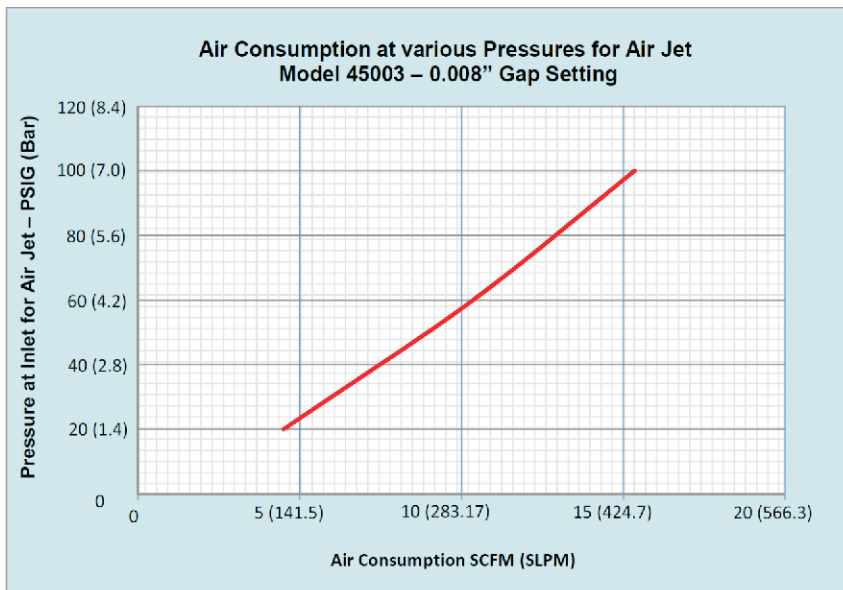
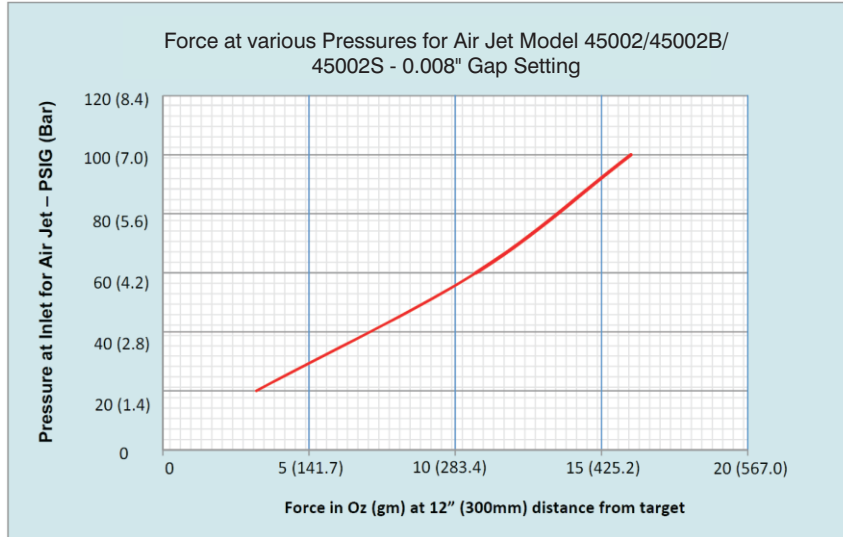

**Air Consumption At Various Pressure for Air Jet Model 45004 - .004" setting.**

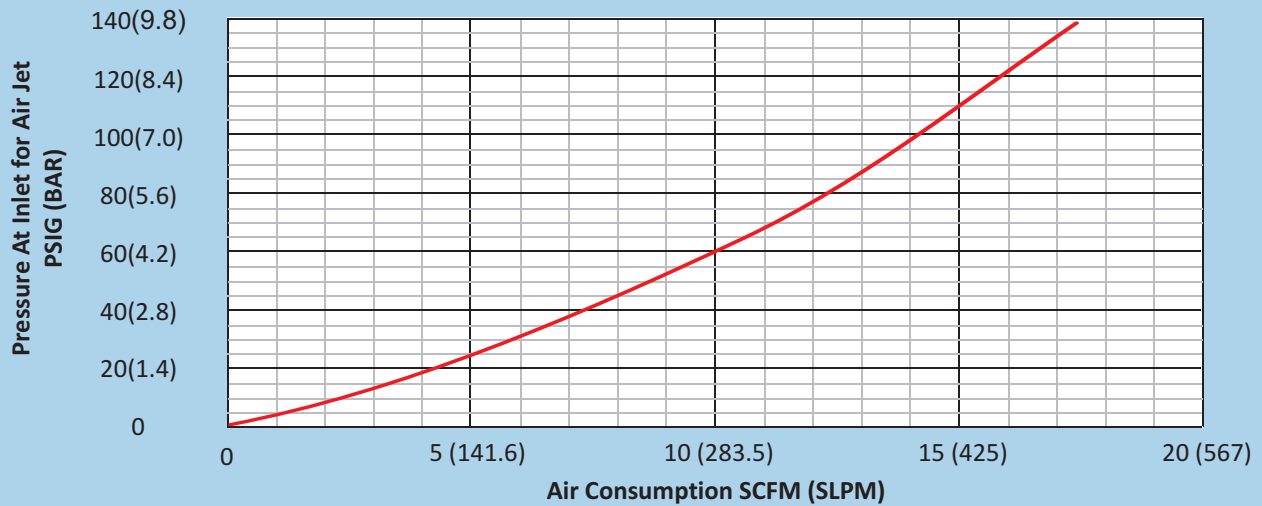

**Force At Various Pressure for Air Jet Model 45004 - .004" setting.**

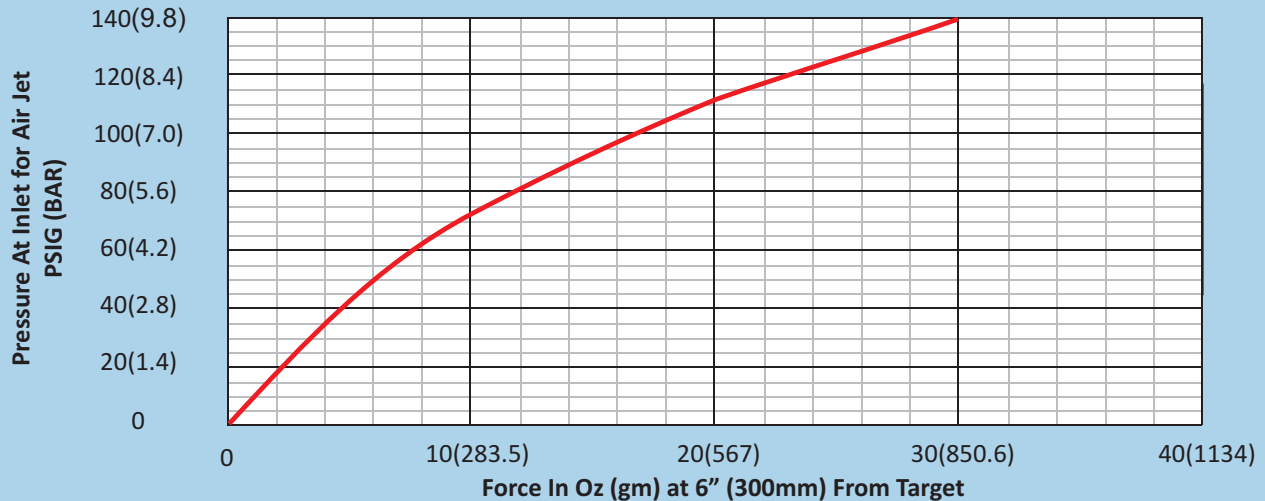

**RIGID FLEX HOSE NOZZLE ACCESSORIES - TO HOLD AND AIM NOZZLES AND JETS**

The unique Nex Flow™ RIGID FLEX hose is an all stainless steel hose that does not break after a few bends like competitive rubber hoses with simple copper inserts. It is resistant to creep and crimping. Its all stainless construction allows it use in any difficult environment. They have 1/4" male NPT welded end connections and come in 6", 12" and 18" overall lengths.



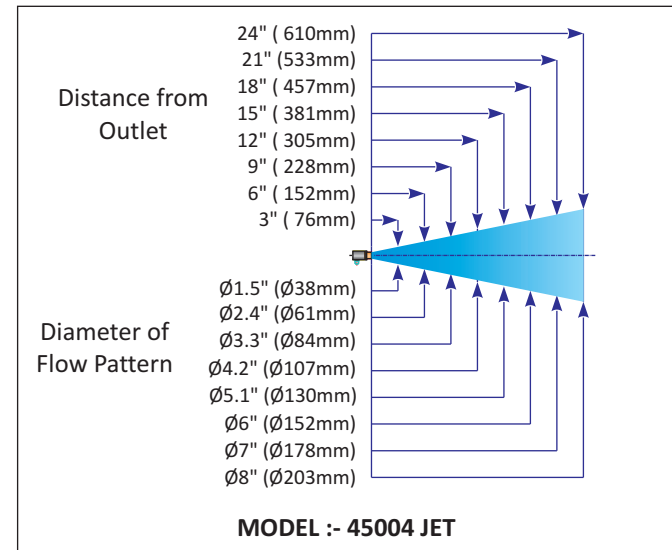
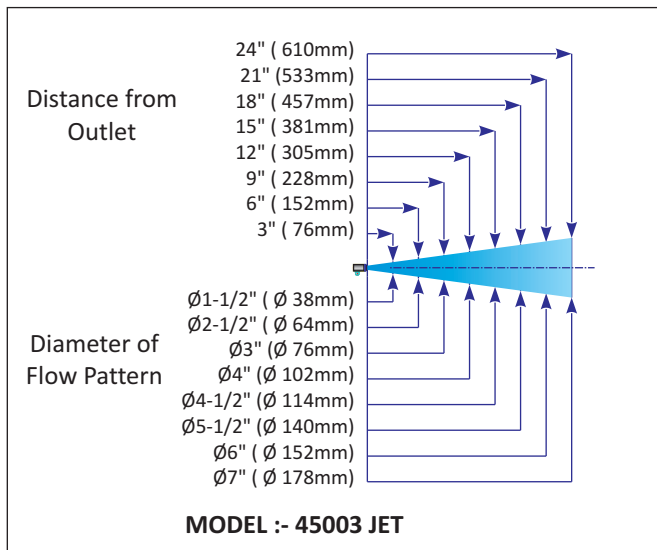
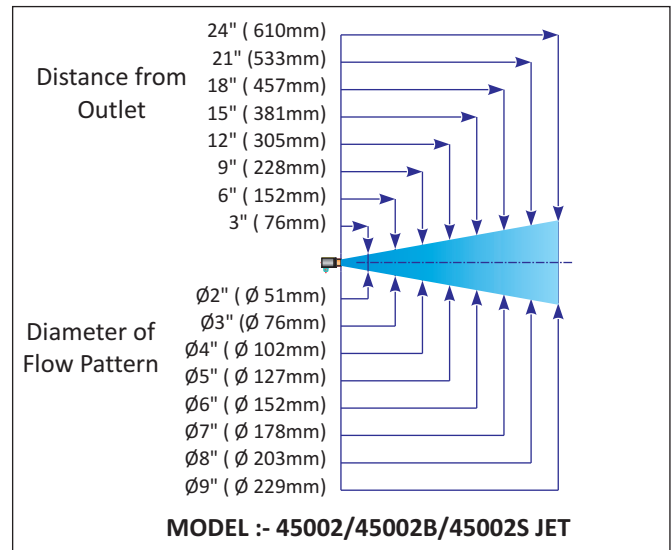
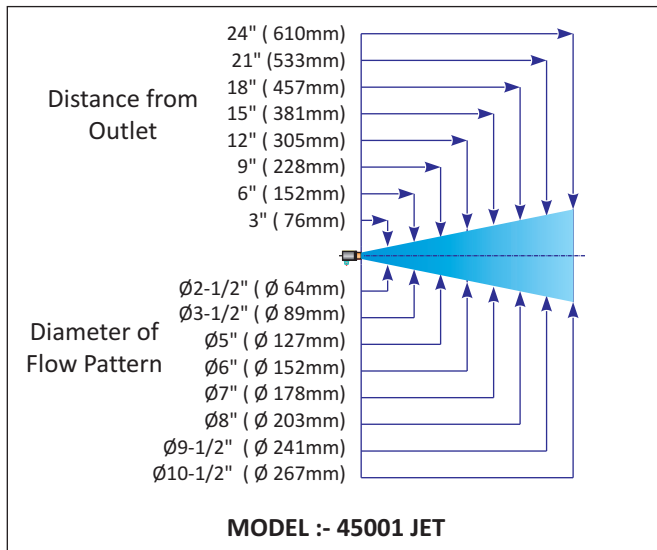

**AIR JETS**

PART NO.	DESCRIPTION
45001	High Flow Air Jet (aluminum, unmarked)
45002	High Force Air Jet (aluminum, unmarked)
45002B	High Force Air Jet (Brass, marked to indicate gap setting)
45002S	High Force Air Jet (316L stainless, marked to indicate gap setting)
45003	Mini - High Force Air jet
45004	Fat Air Jet Air Amplifier (aluminum, unmarked)

**STAINLESS STEEL RIGID FLEX HOSE**

PART NO.	DESCRIPTION
6RF (MM / MF)	6" Stainless Steel Rigid Hose which can be flexed to a shape
12RF (MM / MF)	12" Stainless Steel Rigid Hose which can be flexed to a shape
18RF (MM / MF)	18" Stainless Steel Rigid Hose which can be flexed to a shape

**AIR NOZZLES AND JETS**

## AIR EDGER™ FLAT JET NOZZLE

Superior designed Flat Jet Nozzle reduces compressed air consumption and noise levels

– with the use of different shims can vary the force from weak to strong depending on the application

### WHAT ARE THEY - REASONS TO USE

Model **47011** (cast zinc) **Air Edger™ Flat Jet** and Model **47011S-316L** (316L stainless steel) is an extremely efficient flat jet air nozzle designed to provide a powerful stream of high velocity laminar flow and high force for blow off and cooling where air knives may not be enough

When bench tested against several other flat jets, even those with special designed holes or shims, the **Air Edger™ Flat Jet** outperformed them all despite whatever claims others may make. Air consumption and noise levels are minimized with its special design and configuration.



The **Nex Flow™ Air Edger™ Flat Jet** is available with various size “gaps” all set by a flat shim. Three standard shim sizes are available - .004” (.10 mm), .008” (.2mm) and .020” (.51 mm). One, two or more shims can be “stacked” for a larger gap and greater force.

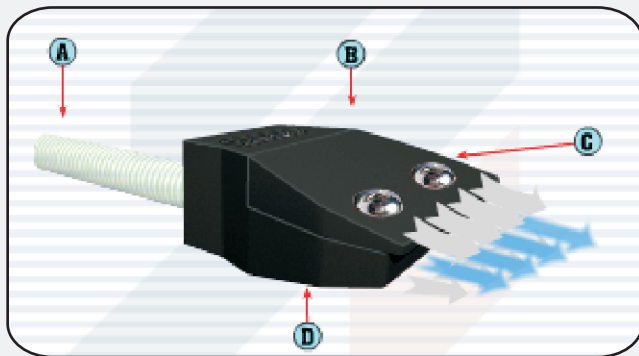

### HOW IT WORKS

Compressed air enters the flat jet at the rear port at (A). Air is entrained at point (B) and (D) by the compressed air stream that leaves the flat jet from a small gap at the end. The entrained air follows the profile that directs the airflow in a perfect straight line to create a uniform sheet of air along the 2” length of the Air Edger™ Flat Jet Nozzle. The amplified air stream maximizes velocity and force to produce a well-defined sharp edge laminar flow with minimal wind shear for reduced energy use in blow off and cooling. Two screws at (C) allow you to vary the gap with a variety of sizes of shims (.004”, .008” or .020”). One or two shims may be used.



Air Edger™ Flat Jet with .008” gap setting blows water from under the caps on a bottling line moving at high speed



Air Edger™ Flat Jet with .020” gap setting provides a powerful force to blow off dirt and debris in an extrusion line

**PERFORMANCE**

**AIR CONSUMPTION AND FORCE**

MODEL Cast Aluminum	MODEL 316L Stainless	SCFM (SLPM) at 80 PSIG Measured at entrance to jet	FORCE in Ounces (grams) at 12" from target
Model 47011-4	Model 47011S-316L-4	20.5 (581)	12 (340)
Model 47011-8	Model 47011S-316L-8	31.3(887)	21 (595)
Model 47011-12	Model 47011S-316L-12	38.5 (1091)	27 (765)
Model 47011-16	Model 47011S-316L-16	41.0 (1161)	30 (850)
Model 47011-20	Model 47011S-316L-20	44.5 (1261)	33 (936)
Model 47011-24	Model 47011S-316L-24	47.0 (1331)	36(1020)
Model 47011-28	Model 47011S-316L-28	51.0 (1445)	39 (1106)

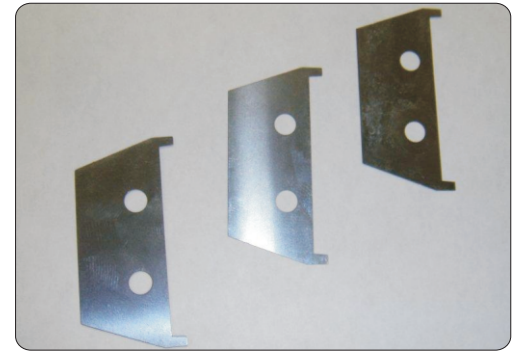

The Air Edger™ Flat Jet Nozzle air gap is set by one or more shims. There are three basic shim sizes - .004" (.1 mm), .008" (.2 mm) and .020" (.5 mm). Shims may be stacked for larger gaps and for sizes in between the shim standard sizes offered. Shims available in both 304 stainless steel & 316L stainless (for the stainless Air Edger™). The greater the gap the more powerful the force.

**DIMENSIONS**

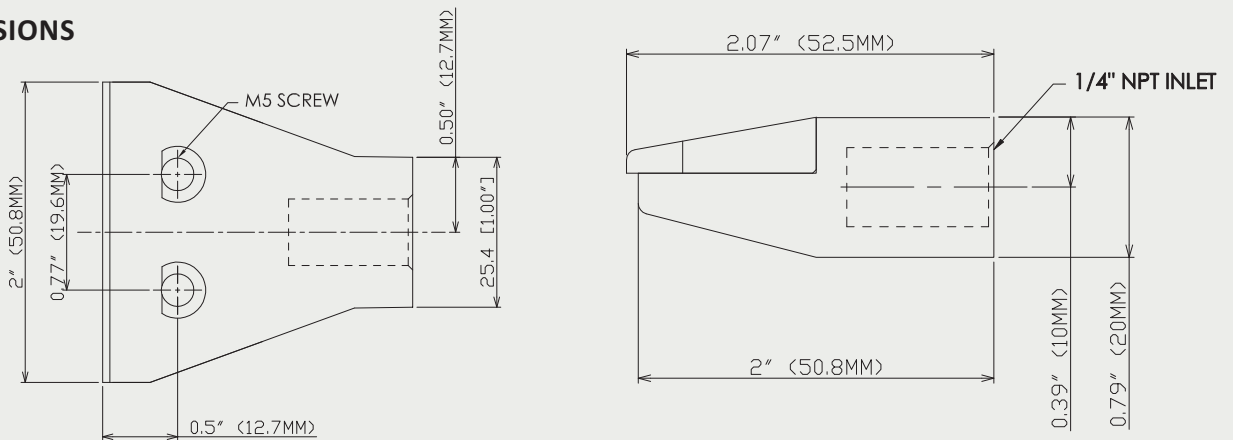

**COMPARED TO COMPETITION**

It is not always clear how tests and measurements are made by competitors and therefore validating claims can be difficult since such values depend on how tests are done. Therefore we measured a competitive unit under the same conditions as we measured our units. The flat jet of the competitor is of a similar type except that they are using a saw tooth shim design and different internal dimensions. We obtained the following readings when measured using the same parameters as for Nex Flow units.

25.1 SCFM AIR CONSUMPTION AND 15 oz force  
(Published figures were 22 SCFM and 22 oz force)

One measure of efficiency is the ratio of Force/Air Consumption. The higher the ratio the better the efficiency. The force/SCFM is a ratio of .54 based on measured figures when measured the same way as the Nex Flow units.

If we compare to that of the Nex Flow Model 47011-4 the ratio is 12/20.5 = .58 And for the Model 47011-8 the ratio is 21/31.3 = .67

In both cases the efficiency of the Nex Flow units are higher in the comparative tests done under the same conditions.

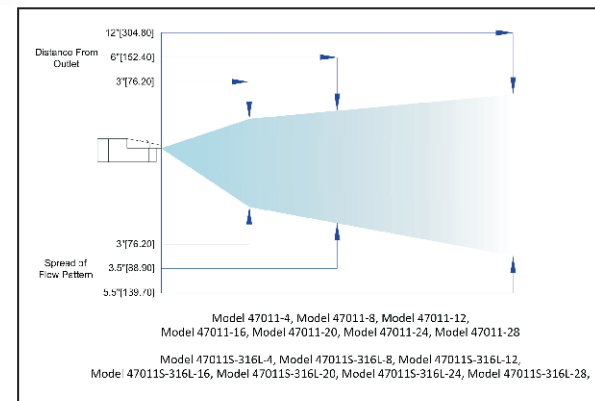



FLAT JET NOZZLES	
PART NO.	DESCRIPTION
47011-4 & 47011S-316L-4	Air Edger™ Flat Jet with .004" gap setting
47011-8 & 47011S-316L-8	Air Edger™ Flat Jet with .008" gap setting
47011-12 & 47011S-316L-12	Air Edger™ Flat Jet with .012" gap setting
47011-16 & 47011S-316L-16	Air Edger™ Flat Jet with .016" gap setting
47011-20 & 47011S-316L-20	Air Edger™ Flat Jet with .020" gap setting
47011-24 & 47011S-316L-24	Air Edger™ Flat Jet with .024" gap setting
47011-28 & 47011S-316L-28	Air Edger™ Flat Jet with .028" gap setting
47111S-4	.004" 304 stainless steel shim
47111S-8	.008" 304 stainless steel shim
47111S-20	.020" 304 stainless steel shim
47211S	304 stainless steel shim set – Two (2) .004", Two (2) .008" and One (1) .020" shim
47111S-316L-4	.004" 316L stainless steel shim
47111S-316L-8	.008" 316L stainless steel shim
47111S-316L-20	.020" 316L stainless steel shim
47211S-316L	316L stainless steel shim set – Two (2) .004", Two (2) .008" and One (1) .020" shim

**NOT SURE OF THE SIZE YOU NEED?**

If you are not sure of which level of power you need, we recommend a Model 47211S Shim Set (for the cast zinc model) or a Model 47211S-316L Shim Set (for the 316L stainless steel model). The shim set consists of 2 - .004" shims, 2 - .008" shims and 1 - .020" shim and any two shims (or more) can be stacked to set the gap best suited to your application.

**RIGID FLEX HOSE NOZZLE ACCESSORIES - TO HOLD AND AIM NOZZLES AND JETS**



The unique Nex Flow™ RIGID FLEX hose is an all stainless steel hose that does not break after a few bends like competitive rubber hoses with simple copper inserts. It is resistant to creep and crimping. Its all stainless construction allows it use in any difficult environment. They have ¼" male NPT welded end connections and come in 6", 12" and 18" overall lengths.



STAINLESS STEEL RIGID FLEX HOSE ( REFER TO PAGE M5 FOR THE RIGID FLEX HOSE )	
PART NO.	DESCRIPTION
6RF (MM / MF)	6" Stainless Steel Rigid Hose which can be flexed to a shape
12RF (MM / MF)	12" Stainless Steel Rigid Hose which can be flexed to a shape
18RF (MM / MF)	18" Stainless Steel Rigid Hose which can be flexed to a shape

**SAFETY AIR BLOWOFF GUNS**

Nex Flow™ Blowoff Guns utilize the efficient and superior Nozzles and Jets to reduce compressed air consumption and noise levels with safety in mind.

**WHAT ARE THEY - REASONS TO USE**

Many low cost Air Guns are sold extensively but do not necessarily last. In addition, they are not all safe to use and may result in dangerous high dead end pressures.

Nex Flow™ safety air blowoff Guns are durable, safe, and comfortable to use incorporating our efficient Air Nozzles and Jets to produce high output air and “laminar” flow while minimizing compressed air use and noise levels.

The most important reason to use safety Air Guns with our Air Nozzles or Jets is safety. All Nex Flow™ Air Nozzles and Jets meet OSHA standard CFR 1910.242(b) for dead end pressure. Noise levels are dramatically lower with Air Nozzles and Jets in addition to lower energy use.

**SELECTION**

There are two types of Safety Air Blowoff Guns to choose from depending on the individual’s personal taste and comfort. See Nozzles and Jets for their technical details.



**EASY GRIP SAFETY GUN**

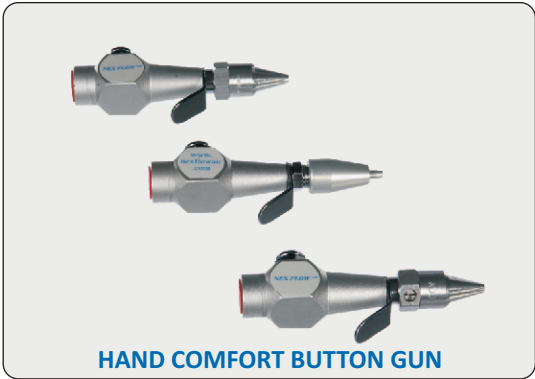

**HAND COMFORT BUTTON GUN**

Nex Flow™ removes the confusion from Air Jets and Nozzles. You do NOT need hundreds of different Nozzles. All air amplifying Nozzles produce air flows up to 25 times the compressed air consumed. Different Nozzles have different outlet sizes and the more air used, the greater the force produced. Noise reduction up to 10 dBA is typical as well as reduced air consumption when compared to open Jets and Tubes.

By maintaining a reasonable choice of Nozzles most valid applications can be addressed with our range.



**EASY GRIP SAFETY GUN**

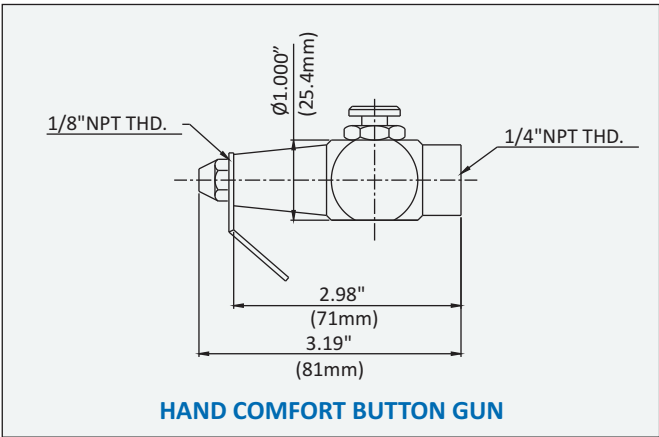

**HAND COMFORT BUTTON GUN**

**SMART N CLEVER™ AIR GUNS**





### EXTENSION TUBE AND RIGID FLEX HOSE

You can add an anodized aluminum Extension Tube or a Rigid Flex Hose to the Easy Grip Gun for extended reach. Tubes are available in 6", 12", 18", 24", and 36" lengths. The Rigid Flex Hose is available in 6" and 12" lengths.

### EASY GRIP SAFETY AIR GUN

PART NO.	DESCRIPTION
49000	Air Gun Only (no nozzle)
49003	Air Gun with 47003 aluminum nozzle
49003S	Air Gun with 47003S 303/304 stainless nozzle
49003S-316L	Air Gun with 47004 aluminum nozzle
49004S	Air Gun with 47004S 303/304 stainless nozzle
49004S-316L	Air Gun with 47004S-316L stainless nozzle
49009	Air Gun with 47009 adjustable aluminum nozzle
49009S	Air Gun with 47009S 303/304 adjustable stainless nozzle
49009S-316L	Air Gun with 47009S-316L adjustable stainless nozzle
49010	Air Gun with 47010 X-stream aluminum nozzle
49002X	Air Gun with 10002 X-stream 2" aluminum Air Blade air knife



### EXTENSIONS FOR EASY GRIP SAFETY AIR GUN

PART NO.	DESCRIPTION
49906	6" Extension
49912	12" Extension
49918	18" Extension
49924	24" Extension
49936	30" Extension

### HAND COMFORT BUTTON GUN

PART NO.	DESCRIPTION
49100	Air Gun Only (no nozzle)
49103	Air Gun with 47003 aluminum nozzle
49103S	Air Gun with 47003S 303/304 stainless nozzle
49103S-316L	Air Gun with 47003S-316L stainless nozzle
49109	Air Gun with 47009 adjustable aluminum nozzle
49109S	Air Gun with 47009S 303/304 adjustable stainless nozzle
49109S-316L	Air Gun with 47009S-316L adjustable stainless nozzle

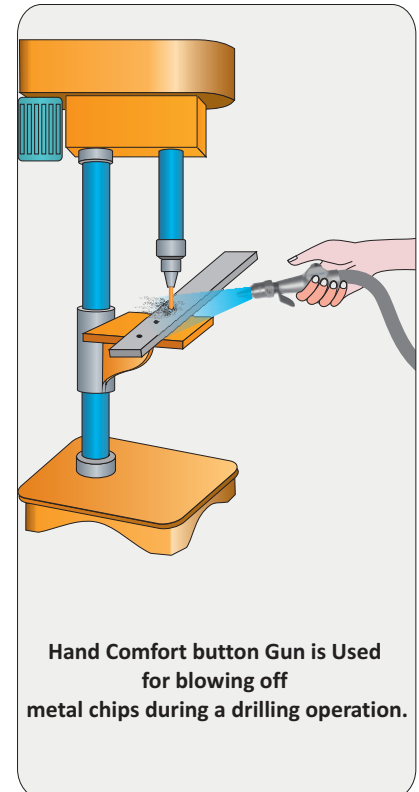

Hand Comfort button Gun is Used for blowing off metal chips during a drilling operation.



## STATIC ELIMINATORS

**Powerful and high quality static eliminators with, and without air amplification products,  
To address virtually any application which static charges are a problem.**

### WHAT ARE THEY - REASONS TO USE

Wild claims are made by some amplification product suppliers that putting a static bar with an Air Knife will eliminate static at incredible distances which are highly exaggerated. We will attempt to clarify such myths with reality.

A static eliminator is a device that produces ions - positive and negative - which neutralize any opposite charge on a surface that these ions interact with. Static charges occur on plastic parts, moving webs of paper and film, and can cause problems of jamming as well as shock hazards to personnel.

Charges can vary on a surface and in some cases (depending on a variety of factors such as material, speed, and humidity) be extremely high. For this reason Nex Flow™ has several options to address the wide variety of environments encountered.

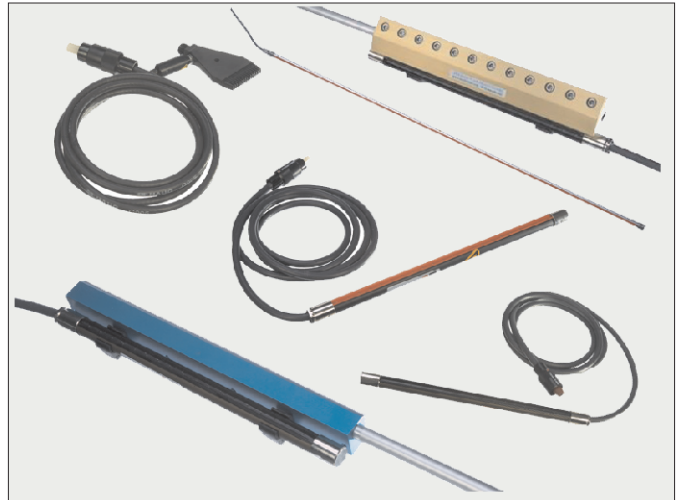

**Nex Flow™ has a variety of static elimination products to address virtually any static application in manufacturing**

### MYTH VERSES REALITY

Static Eliminators are used on their own when they can be placed close to a surface. In all instances it takes “time” for the static to dissipate. When close to a surface it can happen extremely quickly (milliseconds). This can usually be achieved by using a standard strength static bar. In some cases the surface charge may be extremely high (like in some materials as Mylar) and/or the surface may be moving quite quickly on a moving web. In such cases the static bar may not produce enough “ions” fast enough and a more powerful static bar is required. Just adding an Air Knife will NOT speed up static removal. In fact it may slow it down! Nex Flow™ has available a more powerful static bar for such high charged” or high speed applications.

Adding a compressed air “Air Knife” will allow you to remove static at a distance (as will adding a blower) but can increase the time needed to dissipate static as the ions somewhat recombine on their way to the target weakening their effect. Therefore often a stronger static bar (that we can provide) is required.

**All static control equipment meets electrical standards for North America and/or Europe and are ROHS compliant.**



Nex Flow™ uses quality static bars from Haug rather than cheap products because Haug static bars have been proven to last in difficult environments. The most fragile part of any ionization system is the static bar and Haug bars have proven themselves against many others to be durable, of high quality, and long lasting.

**THE MODEL RN STATIC BAR**

The HAUG **RN** Ionizing Bar is a powerful and rugged piece of equipment. Production interfering surface charges can be removed reliably and effectively - even at high operating speeds. The coaxial high-voltage plug-and-socket connection of the HAUG system **X-2000** offers a unique advantage in that the gas tight high-voltage plug can be connected to the HAUG power pack easily and without tools. The flexible, coaxially shielded cable connects the ionizing unit with the voltage supply. The round construction of the RN ionizing bar permits the exact axial adjustment in the direction of travel of the material. The Ionizing Bar is safe to touch. Special wear-resistant electrodes guarantee long service life.



**MODEL RN Static Bar**



**MODEL VS Static Bar**

**THE MODEL VS EXTRA POWERFUL STATIC BAR**

The HAUG **VS** Ionizing Bar reliably removes electrostatic charges and its performance, when compared to the standard version, is three times the power. This tremendously improves the static removal and designed to address extremely high charges, faster speeds and greater distances. The **VS** Ionizing Bar has all of the typical features that characterize HAUG Ionizing Bars: the reliable and removable plug-and-socket connection System **X-2000**, the shielded high-voltage cable, the special stainless-steel electrodes and the convenience of being safe to touch. The electrical capacity of the VS Ionizing Bar is three times as great as the standard version, and therefore, it is necessary to base any power pack load calculations on a bar length three times as long.

**EXPLOSION PROOF STATIC BARS AND POWER SUPPLIES**

The Haug **El Ex T** ionizing units are approved for equipment in areas with potential explosive atmospheres, to eliminate unwanted electrostatic charges where hazardous gases may form, such as paint facilities or printing machines utilizing solvent inks.

The design of the **El Ex T** Ionizing Bar complies with the international ATEX directives in combination with the Model EN 92 or Multistat Ex power supplies. This system is approved for use in manufacturing locations with potentially explosive atmospheres resulting from gases of explosion group IIA, temperature classes T4 to T6.



**MODEL EX T Static Bar**

**MODEL RN STANDARD STRENGTH STATIC BAR**

PART NO.	DESCRIPTION
13003	Haug Model RN Static Bar - 4" LONG
13006	Haug Model RN Static Bar - 7" LONG
13009	Haug Model RN Static Bar - 10" LONG
13012	Haug Model RN Static Bar - 13" LONG
13018	Haug Model RN Static Bar - 19" LONG
13024	Haug Model RN Static Bar - 25" LONG
13030	Haug Model RN Static Bar - 31" LONG
13036	Haug Model RN Static Bar - 37" LONG
13042	Haug Model RN Static Bar - 43" LONG
13048	Haug Model RN Static Bar - 49" LONG
13054	Haug Model RN Static Bar - 55" LONG
13060	Haug Model RN Static Bar - 61" LONG
13066	Haug Model RN Static Bar - 67" LONG
13072	Haug Model RN Static Bar - 73" LONG
13078	Haug Model RN Static Bar - 79" LONG
13084	Haug Model RN Static Bar - 85" LONG

**MODEL VS EXTRA STRENGTH STATIC BAR**

PART NO.	DESCRIPTION
14006	Haug Model VS Static Bar - 7" LONG
14009	Haug Model VS Static Bar - 9" LONG
14012	Haug Model VS Static Bar - 13" LONG
14018	Haug Model VS Static Bar - 19" LONG
14024	Haug Model VS Static Bar - 25" LONG
14030	Haug Model VS Static Bar - 31" LONG
14036	Haug Model VS Static Bar - 37" LONG
14042	Haug Model VS Static Bar - 43" LONG
14048	Haug Model VS Static Bar - 49" LONG
14054	Haug Model VS Static Bar - 55" LONG
14060	Haug Model VS Static Bar - 61" LONG
14066	Haug Model VS Static Bar - 67" LONG
14072	Haug Model VS Static Bar - 73" LONG
14078	Haug Model VS Static Bar - 79" LONG
14084	Haug Model VS Static Bar - 85" LONG

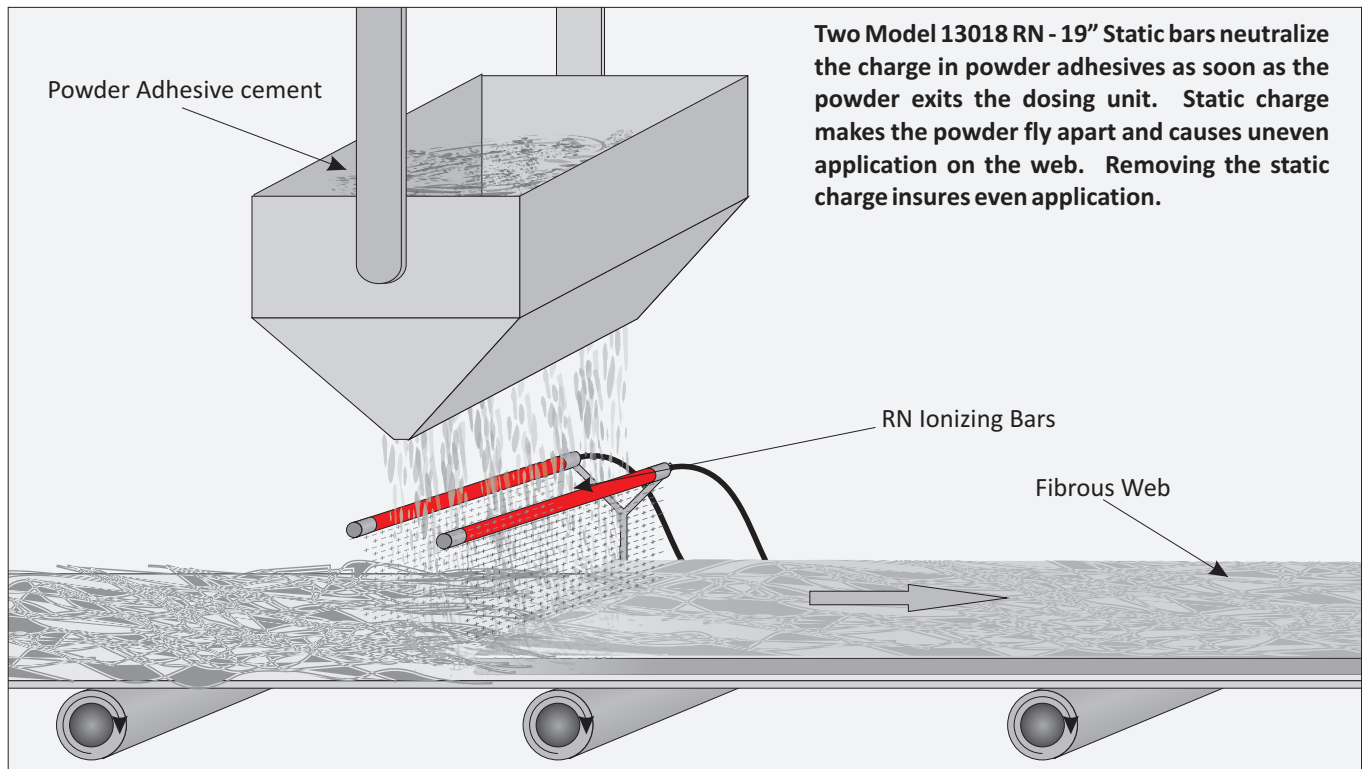

**For Explosion Proof applications consult Factory or your local representative**

**E-mail:-** ■ sales@nexflow.com ■ sales@nexflowair.com ■ sales@nex-flow.com

**Web:-** ■ www.nexflow.com ■ www.nexflowair.com ■ www.nex-flow.com

Nex Flow™ uses quality Power Supplies from Haug that have several unique features unavailable in competitive units.

**Haug Power Supplies are:**

- 1. **Repairable** - parts are replaceable
- 2. **Several versions** - units available with four outlets, two outlets, with or without function monitoring, and in 220V and 110V versions
- 3. **Patent Safety X-2000 Connection** - prevents accidental shocks when connecting or disconnecting a static eliminator to the power supply
- 4. **High Reliability and Life** - so reliable that we even offer a two year warranty on the power supplies

**High Voltage Power Pack Transformers EN - C (2 outlet) and EN-C4 (4 outlet)**

Static Control Power Supply EN-C type High Voltage Power Pack. The integrated high-voltage transformer covers applied mains voltage to approx. 7,000 to 8,000 volts. The unit is equipped with two or four high-voltage terminals and integrated on - off pilot lamp.

Transformers are equipped with a modular-type high-voltage transformer. It consists of three main modules, all of which can be replaced individually. This unit is electrically approved for North American installations.



**S-Line power pack EN SL**

The **S-Line power pack** comes with two high-voltage connections and meets both North American and European standards. The integrated high-voltage transformer covers applied mains voltage to approx. 7,000 to 8,000 volts. Integrated on - off pilot lamp.

**S-Line power pack EN SL LC** - Same as the SL, but with integrated full-electronic function monitoring to constantly monitor all functions of the ionizing system. It alerts the operator of any irregularities by causing the LED indicator integrated in the housing to flash

**EN SL RLC** - Identical in all technical aspects to the EN SL LC plus a signal socket above the earthing sleeve. A fault message can be connected to the signal socket.





**MULTISTAT POWER SUPPLY**



**EN - 92 EX POWER SUPPLY**

**Power pack EN 92 Ex is suitable for direct use in areas with potentially explosive atmospheres (zones 1 or 2).**

The units comply with the International ATEX directives. All high-voltage components are accommodated in a flameproof housing. The power pack **EN 92 Ex** is equipped with two high-voltage ports for the connection of the ionizing units. No long high-voltage cables are required, as the power pack can be installed in the immediate vicinity of the ionizing unit.

**Multistat Power Supply**

The **Multistat** power pack provides the optimum in power pack performance and monitoring. The **Multistat EX** is approved for explosion proof applications (but must be mounted outside the explosion proof area).

**Special features and advantages**

- ▶ Self-balancing high-voltage; no adjustment or settings on the Multistat are required
- ▶ Indication of the output high-voltage by means of an analogue indicating instrument
- ▶ Fault indication in case of insufficient output voltage by means of an optical signal (light-emitting diode - LED) and a floating change-over contact
- ▶ Fault indication in case of insufficient mains voltage by means of a floating change-over contact
- ▶ The floating change-over contact allow both status check and an error check to be performed
- ▶ The **Multistat** allows the integration of the fault signals into a quality assurance system
- ▶ The high-voltage plug-and-socket connector system **X-2000** ensures a secure connection.
- ▶ Four high-voltage terminals

**Function Monitoring**

For an ionization system to work efficiently, a voltage of at least 4.2 kV (Corona inception voltage) is required. By monitoring the electronic control of the output voltage, the high-voltage is continuously monitored; any drop below the corona inception voltage is signaled as malfunction. This fault signal may be linked with the machine control system or the production monitoring system using the socket connection integrated into the housing and a signaling cable.

**POWER SUPPLIES**

North American Approved	
PART NO.	DESCRIPTION
80111	Haug Model ENC-2, 110V, 2-outlet power supply
80112	Haug Model ENC 4, 110V, 4-outlet power supply
80121	Haug Model ENC-2, 220V, 2-outlet power supply
80122	Haug Model ENC 4, 220V, 4-outlet power supply

North American and European Approved	
PART NO.	DESCRIPTION
80321	S-Line EN-SL, 110V, 2-outlet power supply
80322	S-Line EN-SL, 220V, 2-outlet power supply
80421	S-Line EN SL LC, 110V, 2-outlet power supply
80422	S-Line EN SL LC, 220V, 2-outlet power supply
80221	Haug Multistat, 4-outlet, 110V power supply
80222	Haug Multistat, 4-outlet, 220V power supply

**For Explosion Proof applications contact Factory or local Representative**



## SILENT X-STREAM™ AIR BLADE™ IONIZER

**Powerful and quiet static eliminator rapidly dissipates static charge and removes dust.**

The Silent X-Stream™ Air-Blade™ Air Knife utilizes the quality Haug static bars - the RN bar for most applications or the extra strong VS bars (Triple X versions) for very high static charges and extremely high speeds. The Silent X-Stream™ Air-Blade™ Air Knife uses a small amount of compressed air for a powerful, and adjustable force with "laminar" flow to eliminate charges in applications where static bars cannot reach or where high speeds are a factor, and to clean the surface.

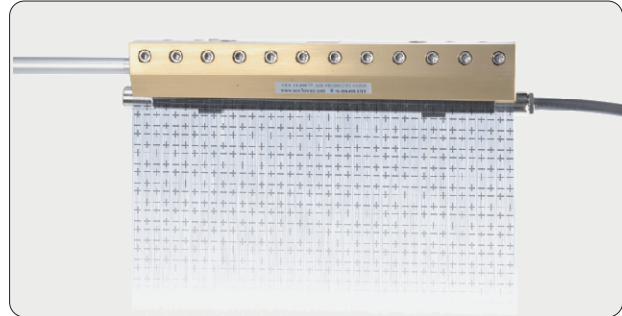

Normally the Standard Model RN Haug brand static bar can address most applications. For extremely high speeds and high charges the extra powerful VS model is used. For wash down applications (such as pharmaceutical areas), a washable model is available at extra cost. **(Contact factory for information)**

All Haug static bars come with a patented safety connector and fully shielded cable. The power supplies are "repairable" and are so well made, that we offer a two year warranty on them (one year on the bars).

### SILENT X-STREAM™ AIR-BLADE™ IONIZER FEATURES:

- ▶ Connections on the back or ends
- ▶ It flows from end to end (full flow).
- ▶ Stainless steel models are available for high temperature and corrosive environments.
- ▶ Models are designed for easy cleaning and prevention of dirt entering the static bar, minimizing potential damage.
- ▶ Patented connectors with the ground intrinsic to the cable design.
- ▶ Instant ON/OFF with no moving parts.
- ▶ Repairable Power Supply with a two year warranty.

### SILENT X-STREAM™ AIR-BLADE™ IONIZER BENEFITS:

- ▶ Flexible mounting options.
- ▶ Units can be mounted end to end for longer lengths with no air gap.
- ▶ High temperature, extra strength, and even a unique washable stainless steel model is available for special applications or as required.
- ▶ Ease of cleaning and maintenance.
- ▶ No separate ground connection that can be cut and cause sparks or accidentally shock personnel
- ▶ Conserves air use when not required.
- ▶ Eliminates one costly area which is power supply replacement. 2 year warranty on power supplies.

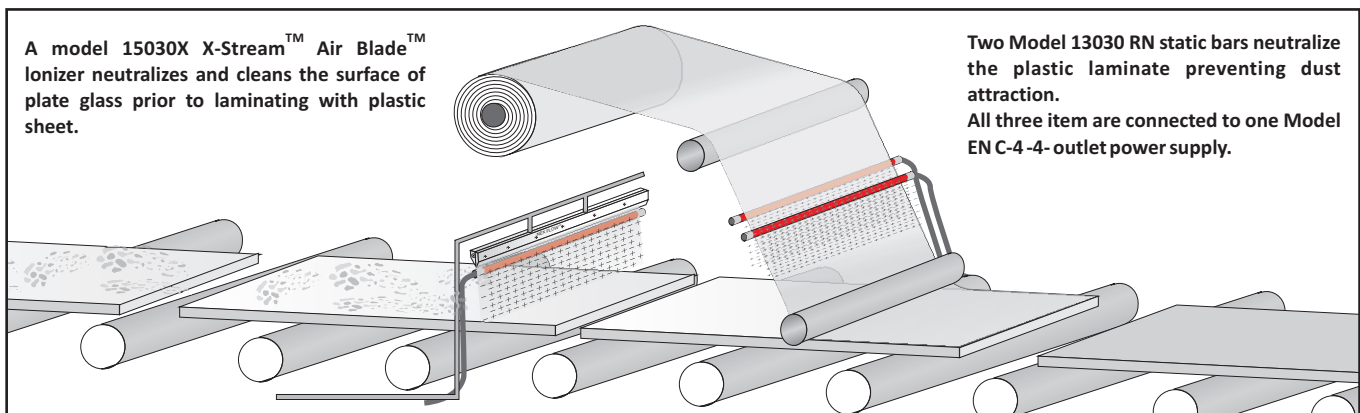

A model 15030X X-Stream™ Air Blade™ Ionizer neutralizes and cleans the surface of plate glass prior to laminating with plastic sheet.

Two Model 13030 RN static bars neutralize the plastic laminate preventing dust attraction. All three items are connected to one Model EN C-4 -4- outlet power supply.

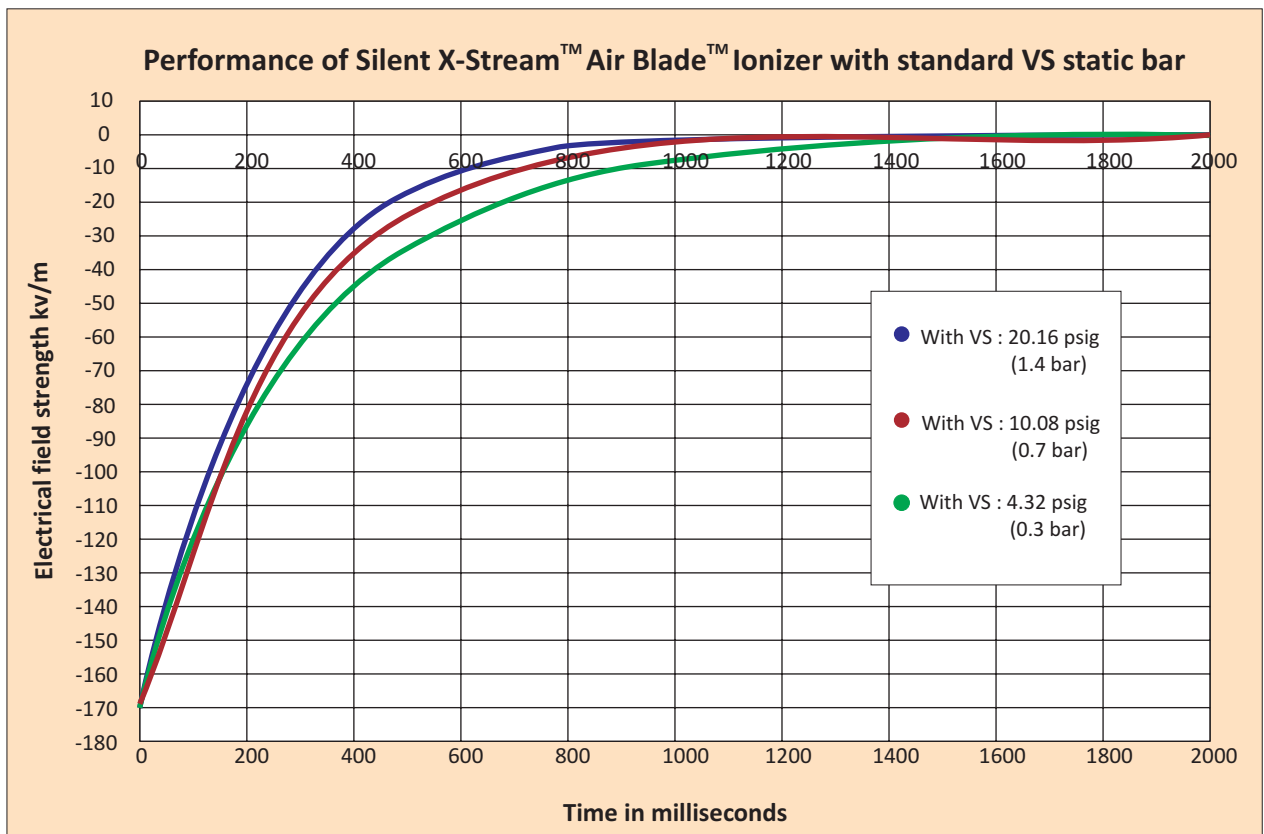
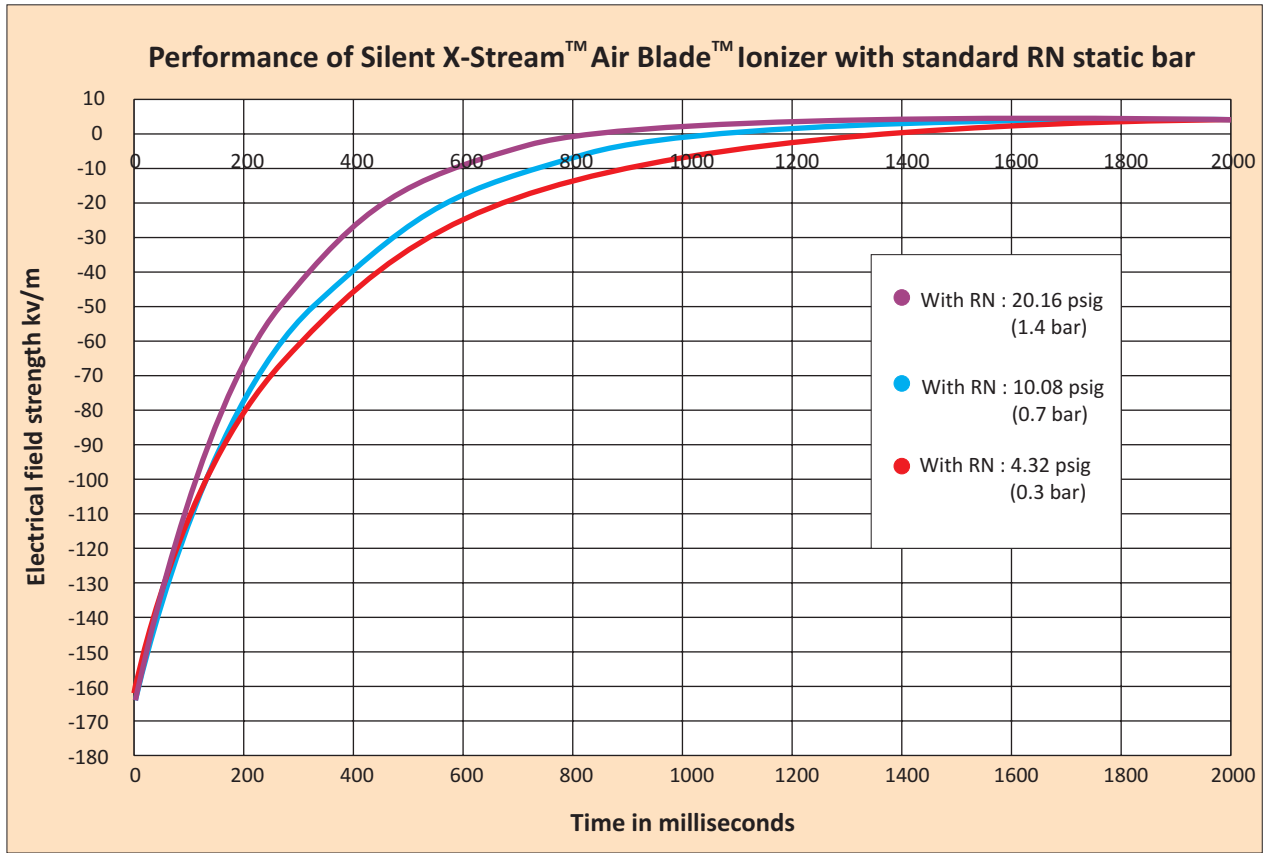

**STATIC ELIMINATORS**

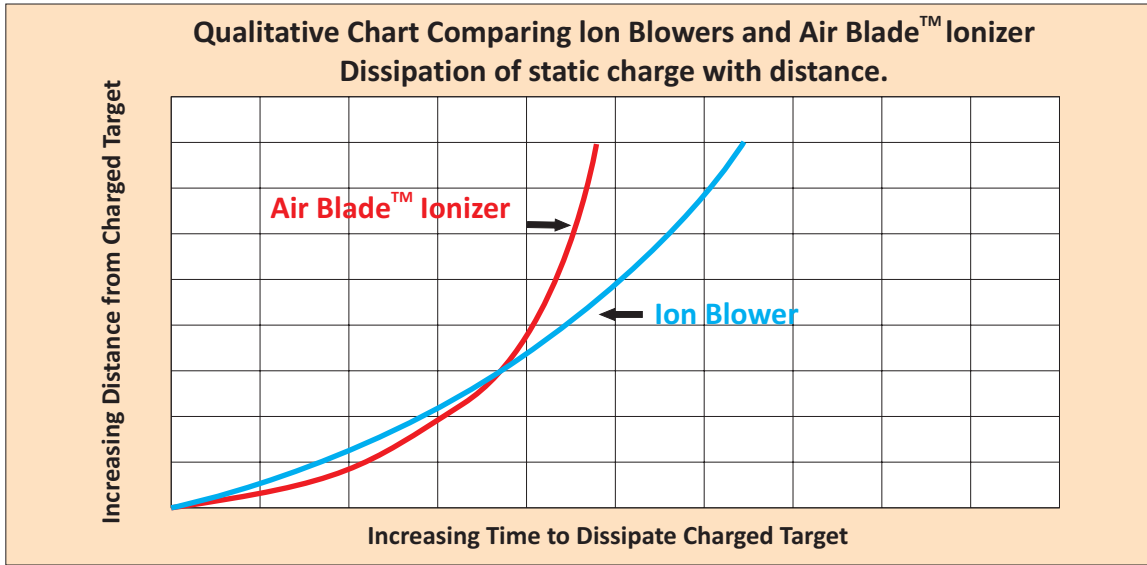

**PERFORMANCE AND RELIABILITY**

The standard RN static bar is very effective when mounted close to a surface (within an inch) at speeds up to 800 feet per minute and the strong VS bar can work to speeds up to 2000 feet per minute mounted as close or at slower speeds up to 8 inches away. For greater distances and high speeds the addition of air is required. The laminar flow from an Air Blade™ Air Knife will extend the effectiveness over this extra distance. Even with laminar flow the ions will recombine and slow static dissipation slightly. For very highly charged surfaces and very high speeds, the extra strong VS static bar may be required. Apart from distance, the Air Blade™ Air Knife allows enough force for blow-off of dust and dirt with little required. Blowers can actually be more effective in static removal closer to the surface but the Air Blade™ ionizer is more effective when further away (see chart comparing blowers and Air Blade™ ionizers above). This is why we recommend stronger static bars like our VS static bar for blowers when far from the target. Blowers however do not offer adequate blow-off force to clean unless they have very high flow and high static pressure. But when not close to the target, blower systems will still require a stronger static bar to match the rate of dissipation that an Air Blade™ ionizer can offer. The X-Stream™ Air Blade™ ionizer can work well for dust and dirt blow-off within the range of 20 to 40 PSIG (1.4 to 2.8 Bar) line pressure.

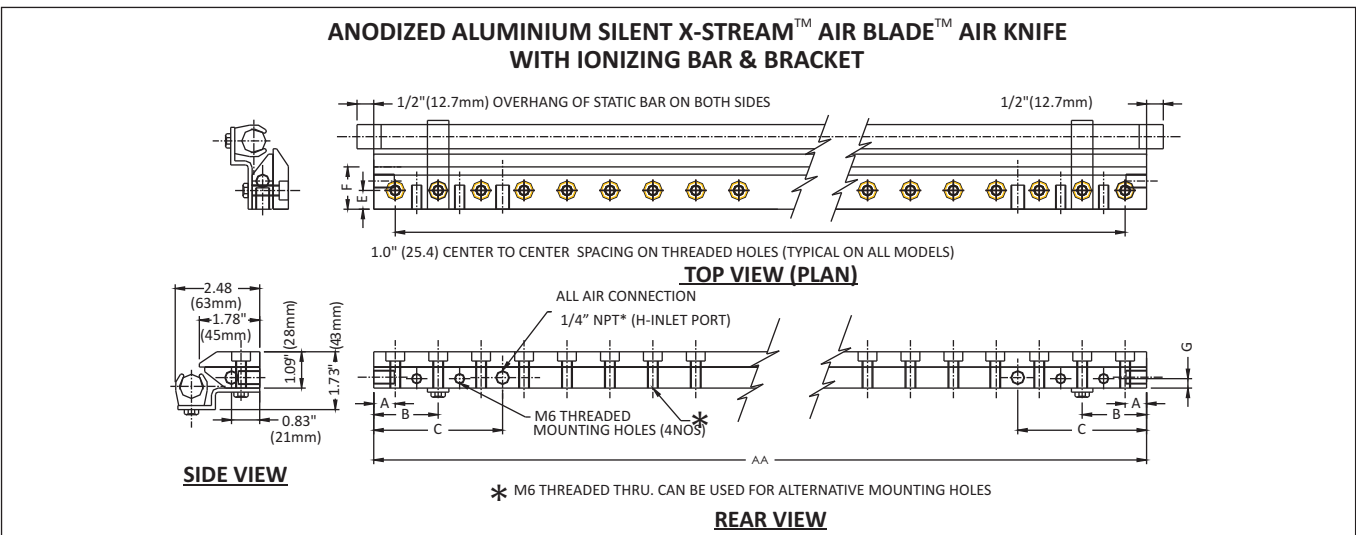

For Air Knife Dimensions please refer page B4

(\* BSP Threads or Adaptors can be supplied depending on country location)

**X-STREAM™ AIR BLADE™ IONIZERS**

PART NO.	DESCRIPTION
15003X	One 3" X-Stream™ Air Blade™ c/w Model RN Static Bar
15006X	One 6" X-Stream™ Air Blade™ c/w Model RN Static Bar
15009X	One 9" X-Stream™ Air Blade™ c/w Model RN Static Bar
15012X	One 12" X-Stream™ Air Blade™ c/w Model RN Static Bar
15018X	One 18" X-Stream™ Air Blade™ c/w Model RN Static Bar
15024X	One 24" X-Stream™ Air Blade™ c/w Model RN Static Bar
15030X	One 30" X-Stream™ Air Blade™ c/w Model RN Static Bar
15036X	One 36" X-Stream™ Air Blade™ c/w Model RN Static Bar
15042X	One 42" X-Stream™ Air Blade™ c/w Model RN Static Bar
15048X	48" (Two 24") X-Stream™ Air Blade™ c/w Model RN Static Bar
15054X	54" (One 24" & One 30") X-Stream™ Air Blade™ c/w Model RN Static Bar
15060X	60" (Two 30") X-Stream™ Air Blade™ c/w Model RN Static Bar
15066X	66" (One 30" & One 36") X-Stream™ Air Blade™ c/w Model RN Static Bar
15072X	72" (Two 36") X-Stream™ Air Blade™ c/w Model RN Static Bar
15078X	78" (One 36" & One 42") X-Stream™ Air Blade™ c/w Model RN Static Bar
15084X	84" (Two 42") X-Stream™ Air Blade™ c/w Model RN Static Bar
15103X	3" X-Stream™ Air Blade™ Ionizer plus ENC-2 Power Supply
15106X	6" X-Stream™ Air Blade™ Ionizer plus ENC-2 Power Supply
15109X	9" X-Stream™ Air Blade™ Ionizer plus ENC-2 Power Supply
15112X	12" X-Stream™ Air Blade™ Ionizer plus ENC-2 Power Supply
15118X	18" X-Stream™ Air Blade™ Ionizer plus ENC-2 Power Supply
15124X	24" X-Stream™ Air Blade™ Ionizer plus ENC-2 Power Supply
15130X	30" X-Stream™ Air Blade™ Ionizer plus ENC-2 Power Supply
15136X	36" X-Stream™ Air Blade™ Ionizer plus ENC-2 Power Supply
15142X	42" X-Stream™ Air Blade™ Ionizer plus ENC-2 Power Supply
15148X	48" X-Stream™ Air Blade™ Ionizer plus ENC-2 Power Supply
15154X	54" X-Stream™ Air Blade™ Ionizer plus ENC-2 Power Supply
15160X	60" X-Stream™ Air Blade™ Ionizer plus ENC-2 Power Supply
15166X	66" X-Stream™ Air Blade™ Ionizer plus ENC-2 Power Supply
15172X	72" X-Stream™ Air Blade™ Ionizer plus ENC-2 Power Supply
15178X	78" X-Stream™ Air Blade™ Ionizer plus ENC-2 Power Supply
15184X	84" X-Stream™ Air Blade™ Ionizer plus ENC-2 Power Supply

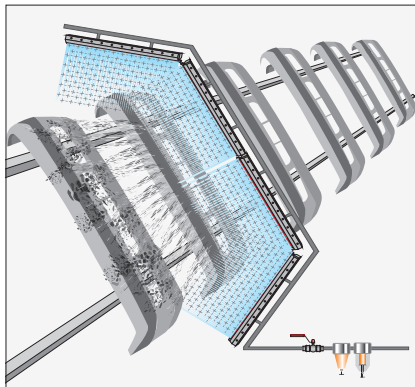

Three 24" X-Stream™ Air Blade™ Ionizers Blow off dust from Automotive Bumpers prior to painting. The NEX FLOW™ PLCFC controls the air on and off as required minimizing air consumption. In this case the static bars were "daisy-chained" together minimizing extraneous cable and reducing the number of power supplies needed.

**STATIC ELIMINATORS**

**SUPER TRIPLE X-STREAM™ AIR BLADE™ IONIZERS**

PART NO.	DESCRIPTION
16006X	One 6" Super Triple X-Stream™ Air Blade™ c/w Model VS Static Bar
16009X	One 9" Super Triple X-Stream™ Air Blade™ c/w Model VS Static Bar
16012X	One 12" Super Triple X-Stream™ Air Blade™ c/w Model VS Static Bar
16018X	One 18" Super Triple X-Stream™ Air Blade™ c/w Model VS Static Bar
16024X	One 24" Super Triple X-Stream™ Air Blade™ c/w Model VS Static Bar
15030X	One 30" Super Triple X-Stream™ Air Blade™ c/w Model VS Static Bar
16036X	One 36" Super Triple X-Stream™ Air Blade™ c/w Model VS Static Bar
16042X	One 42" Super Triple X-Stream™ Air Blade™ c/w Model VS Static Bar
16048X	48" (Two 24") Super Triple X-Stream™ Air Blade™ c/w Model VS Static Bar
16054X	54" (One 24" & One 30") Super Triple X-Stream™ Air Blade™ c/w Model VS Static Bar
16060X	60" (Two 30") Super Triple X-Stream™ Air Blade™ c/w Model VS Static Bar
16066X	66" (One 30" & One 36") Super Triple X-Stream™ Air Blade™ c/w Model VS Static Bar
16072X	72" (Two 36") Super Triple X-Stream™ Air Blade™ c/w Model VS Static Bar
16078X	78" (One 36" & One 42") Super Triple X-Stream™ Air Blade™ c/w Model VS Static Bar
16084X	84" (Two 42") Super Triple X-Stream™ Air Blade™ c/w Model VS Static Bar
16106X	6" Super Triple X-Stream™ Air Blade™ Ionizer plus ENC-2 Power Supply
16109X	9" Super Triple X-Stream™ Air Blade™ Ionizer plus ENC-2 Power Supply
16112X	12" Super Triple X-Stream™ Air Blade™ Ionizer plus ENC-2 Power Supply
16118X	18" Super Triple X-Stream™ Air Blade™ Ionizer plus ENC-2 Power Supply
16124X	24" Super Triple X-Stream™ Air Blade™ Ionizer plus ENC-2 Power Supply
16130X	30" Super Triple X-Stream™ Air Blade™ Ionizer plus ENC-2 Power Supply
16136X	36" Super Triple X-Stream™ Air Blade™ Ionizer plus ENC-2 Power Supply
16142X	42" Super Triple X-Stream™ Air Blade™ Ionizer plus ENC-2 Power Supply
16148X	48" Super Triple X-Stream™ Air Blade™ Ionizer plus ENC-2 Power Supply
16154X	54" Super Triple X-Stream™ Air Blade™ Ionizer plus ENC-2 Power Supply
16160X	60" Super Triple X-Stream™ Air Blade™ Ionizer plus ENC-2 Power Supply
16166X	66" Super Triple X-Stream™ Air Blade™ Ionizer plus ENC-2 Power Supply
16172X	72" Super Triple X-Stream™ Air Blade™ Ionizer plus ENC-2 Power Supply
16178X	78" Super Triple X-Stream™ Air Blade™ Ionizer plus ENC-2 Power Supply
16184X	84" Super Triple X-Stream™ Air Blade™ Ionizer plus ENC-2 Power Supply

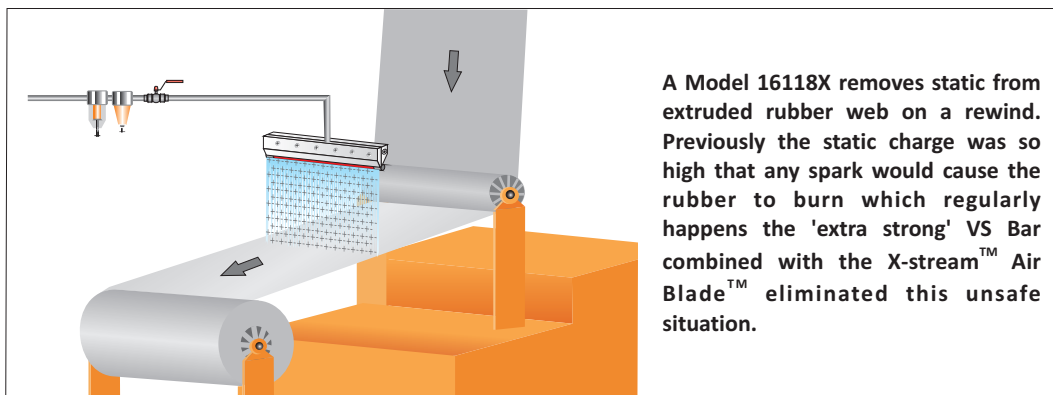

A Model 16118X removes static from extruded rubber web on a rewind. Previously the static charge was so high that any spark would cause the rubber to burn which regularly happens the 'extra strong' VS Bar combined with the X-stream™ Air Blade™ eliminated this unsafe situation.

## STANDARD AIR BLADE™ IONIZER

**A Low Cost but powerful static eliminator that rapidly removes static charge and cleans**

The Standard Air Blade™ Ionizer combines the superior designed Standard Air Blade™ Air Knife the quality Haug static bars - the RN bar for most applications or the extra strong VS bars (Triple X versions) for very high static charges and extremely high speeds. The standard Air-Blade™ Air Knife uses slightly more compressed air than the Silent X-Stream™ Air Blade™ and has a higher sound level but still produces a powerful, and adjustable force with "laminar" flow to eliminate charges in applications where static bars cannot reach or where high speeds are a factor.

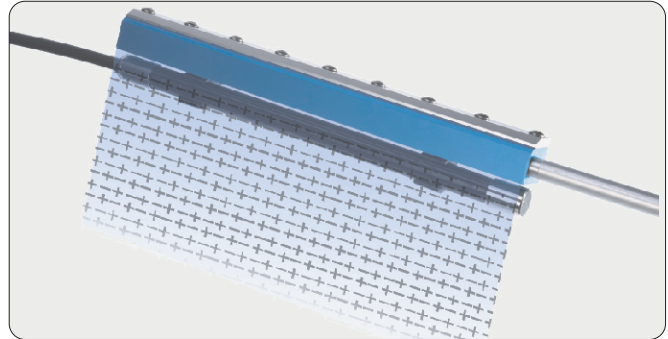

Normally the Standard Model RN Haug brand static bar can address most applications. For extremely high speeds and high charges the extra powerful VS model is used. For wash down applications (such as pharmaceutical areas), a washable model is available at extra cost. **(Contact factory for information)**

All Haug static bars come with a patented safety connector and fully shielded cable. The power supplies are "repairable" and are so well made, that we offer a two year warranty on them (one year on the bars).

### STANDARD AIR BLADE™ IONIZER FEATURES:

- ▶ Connections on the back or ends.
- ▶ It flows from end to end (full flow).
- ▶ Stainless steel models are available for high temperature and corrosive models.
- ▶ Models are designed for easy cleaning and prevention of dirt entering the static bar, minimizing potential damage.
- ▶ Patented connectors with the ground intrinsic to the cable design.
- ▶ Instant ON/OFF with no moving parts.
- ▶ Repairable Power Supply with a two year warranty.

### STANDARD AIR BLADE™ IONIZER BENEFITS:

- ▶ Flexible mounting options.
- ▶ Units can be mounted end to end for longer lengths with no air gap.
- ▶ High temperature, extra strength, and even a unique washable stainless steel model is available for special applications or as required.
- ▶ Ease of cleaning and maintenance.
- ▶ No separate ground connection that can be cut and cause sparks or accidentally shock personnel.
- ▶ Conserves air use when not required.
- ▶ Eliminates one costly area which is power supply replacement. 2 year warranty on.

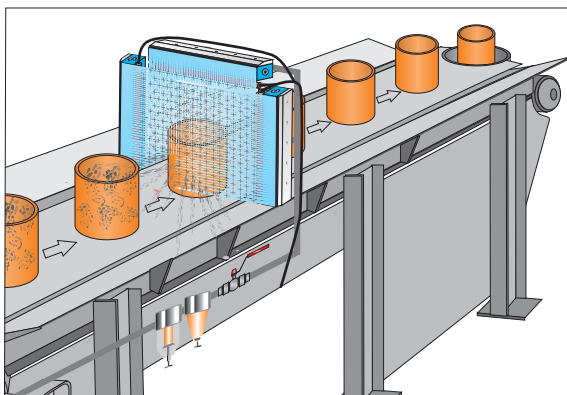

Three Model 15012 Standard Air Blade™ ionizer with 'extra strong' model VS static bar is used to remove the static charge from containers moving at high speed prior to filling. The ionized air is blown in to the container to remove the static charge. All the static bars will connect with 4 outlet power supply. The VS Bars have to be used because of the high speed of container.

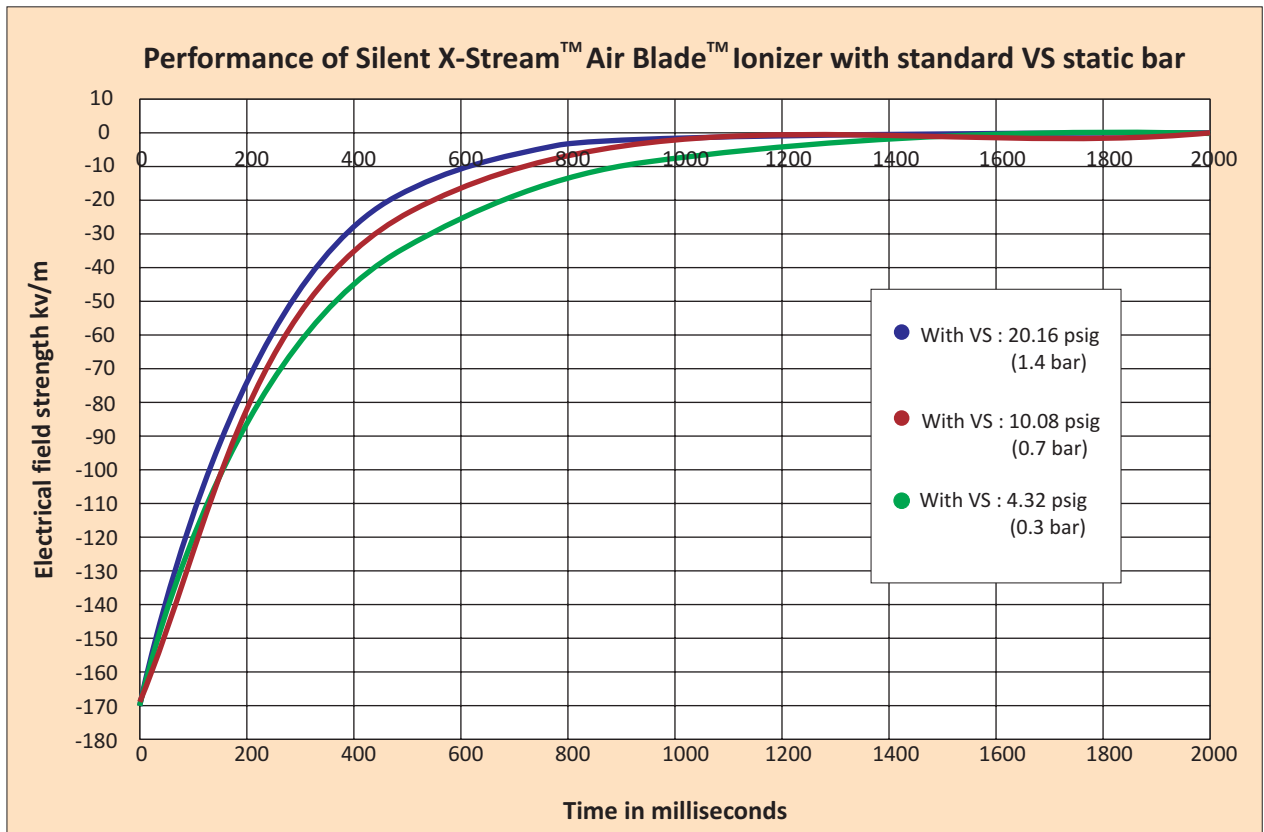
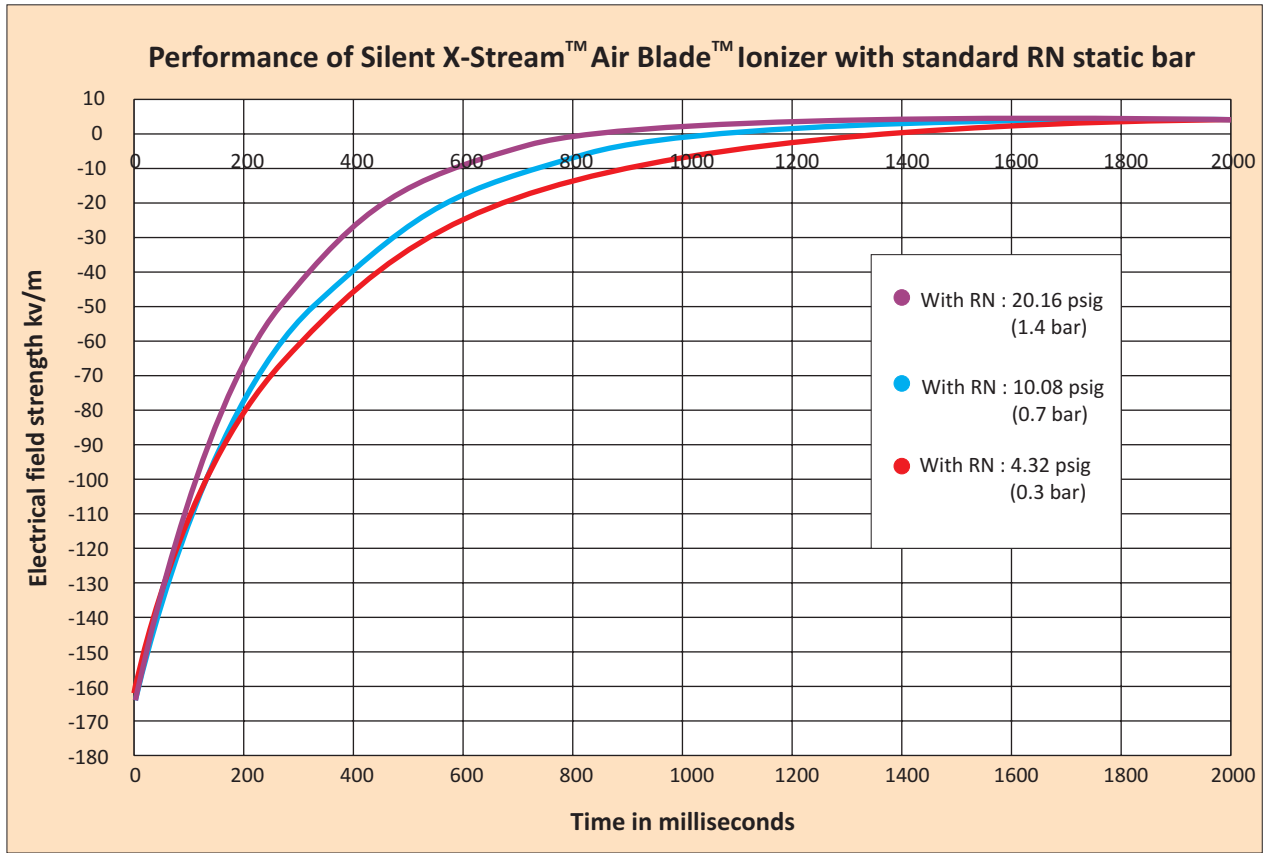

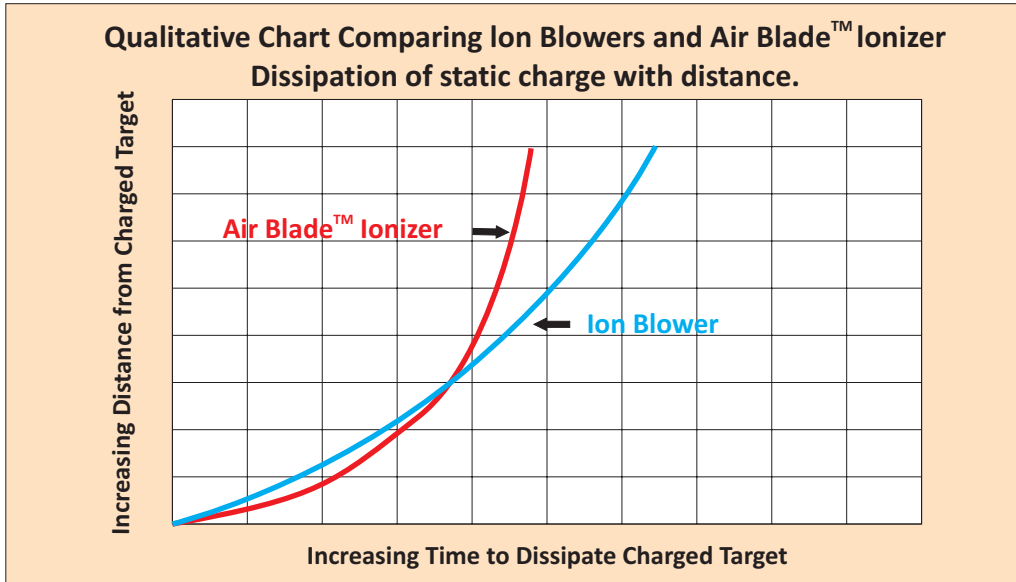

**PERFORMANCE AND RELIABILITY**

The standard RN static bar is very effective when mounted close to a surface (within an inch) at speeds up to 800 feet per minute and the strong VS bar can work to speeds up to 2000 feet per minute mounted as close or at slower speeds up to 8 inches away. For greater distances and high speeds the addition of air is required. The laminar flow from an Air Blade™ Air Knife will extend the effectiveness over this extra distance. Even with laminar flow the ions will recombine and slow static dissipation slightly. For very highly charged surfaces and very high speeds, the extra strong VS static bar may be required. Apart from distance, the Air Blade™ Air Knife allows enough force for blowoff of dust and dirt with little required. Blowers can actually be more effective in static removal closer to the surface but the Air Blade™ Ionizer is more effective when further away (see chart comparing blowers and Air Blade™ Ionizers above). This is why we recommend stronger static bars like our VS static bar for blowers when far from the target. Blowers however do not offer adequate blowoff force to clean unless they have very high flow and high static pressure. But when not close to the target, blower systems will still require a stronger static bar to match the rate of dissipation that an Air Blade™ Ionizer can offer. The Standard Air Blade™ Ionizer can work well for dust and dirt blowoff within the range of 20 to 40 PSIG (1.4 to 2.8 Bar) line pressure.

**STATIC ELIMINATORS**

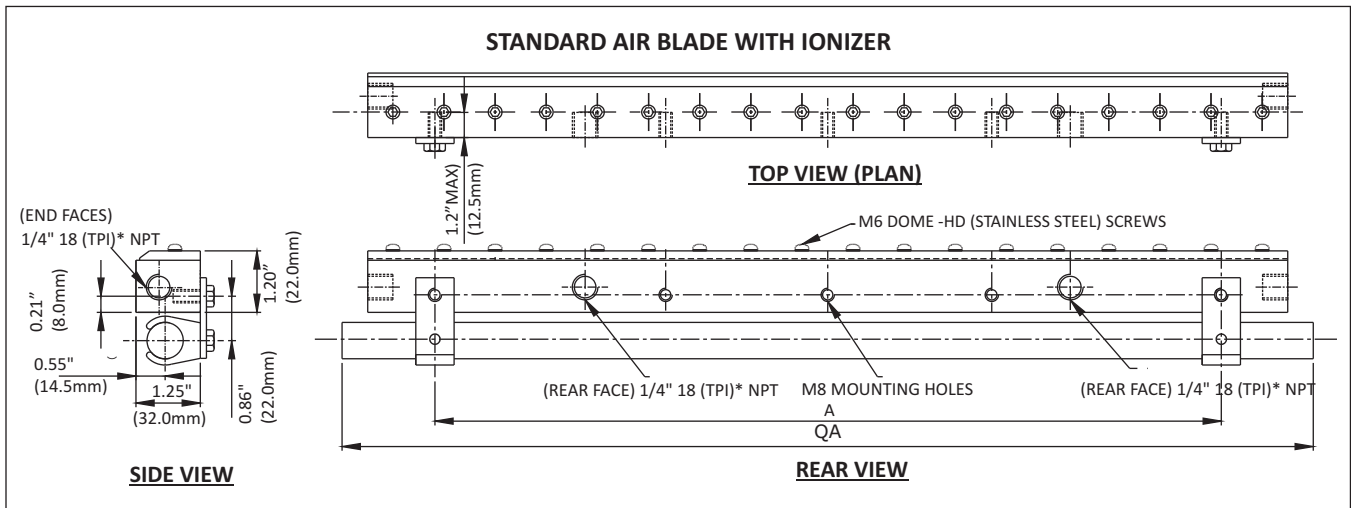

For Air Knife Dimensions please refer page B15

(\* BSP Threads or Adaptors can be supplied depending on country location)



**STANDARD AIR BLADE™ IONIZERS**

PART NO.	DESCRIPTION
15003	One 3" Standard Air Blade™ c/w Model RN Static Bar
15006	One 6" Standard Air Blade™ c/w Model RN Static Bar
15012	One 12" Standard Air Blade™ c/w Model RN Static Bar
15018	One 18" Standard Air Blade™ c/w Model RN Static Bar
15024	One 24" Standard Air Blade™ c/w Model RN Static Bar
15030	One 30" Standard Air Blade™ c/w Model RN Static Bar
15036	One 36" Standard Air Blade™ c/w Model RN Static Bar
15042	42" (One 24" & one 18") Standard Air Blade™ c/w Model RN Static Bar
15048	48" (Two 24") Standard Air Blade™ c/w Model RN Static Bar
15054	54" (One 24" & One 30 Standard Air Blade™ c/w Model RN Static Bar
15060	60" (Two 30 Standard Air Blade™ c/w Model RN Static Bar
15066	66" (One 30" & One 36") Standard Air Blade™ c/w Model RN Static Bar
15072	72" (Two 36") Standard Air Blade™ c/w Model RN Static Bar
15103	3" Standard Air Blade™ Ionizer plus ENC-2 Power Supply
15106	6" Standard Air Blade™ Ionizer plus ENC-2 Power Supply
15112	12 Standard Air Blade™ Ionizer plus ENC-2 Power Supply
15118	18" Standard Air Blade™ Ionizer plus ENC-2 Power Supply
15124	24" Standard Air Blade™ Ionizer plus ENC-2 Power Supply
15130	30" Standard Air Blade™ Ionizer plus ENC-2 Power Supply
15136	36" Standard Air Blade™ Ionizer plus ENC-2 Power Supply
15142	42" Standard Air Blade™ Ionizer plus ENC-2 Power Supply
15148	48" Standard Air Blade™ Ionizer plus ENC-2 Power Supply
15154	54" Standard Air Blade™ Ionizer plus ENC-2 Power Supply
15160	60" Standard Air Blade™ Ionizer plus ENC-2 Power Supply
15166	66" Standard Air Blade™ Ionizer plus ENC-2 Power Supply
15172	72" Standard Air Blade™ Ionizer plus ENC-2 Power Supply

**SUPER TRIPLE STANDARD AIR BLADE™ IONIZERS**

PART NO.	DESCRIPTION
16006	One 6" Super Triple Standard Air Blade™ c/w Model VS Static Bar
16012	One 12" Super Triple Standard Air Blade™ c/w Model VS Static Bar
16018	One 18" Super Triple Standard Air Blade™ c/w Model VS Static Bar
16024	One 24" Super Triple Standard Air Blade™ c/w Model VS Static Bar
16030	One 30" Super Triple Standard Air Blade™ c/w Model VS Static Bar
16036	One 36" Super Triple Standard Air Blade™ c/w Model VS Static Bar
16042	42" (One 24" & one 18") Super Triple Standard Air Blade™ c/w Model VS Static Bar
16048	48" (Two 24") Super Triple Standard Air Blade™ c/w Model VS Static Bar
16054	54" (One 24" & One 30") Super Triple Standard Air Blade™ c/w Model VS Static Bar
16060	60" (Two 30") Super Triple Standard Air Blade™ c/w Model VS Static Bar
16066	66" (One 30" & One 36") Super Triple Standard Air Blade™ c/w Model VS Static Bar
16072	72" (Two 36 Super Triple Standard Air Blade™ c/w Model VS Static Bar
16106	6" Super Triple Standard Air Blade™ Ionizer plus ENC-2 Power Supply
16112	12" Super Triple Standard Air Blade™ Ionizer plus ENC-2 Power Supply
16118	18" Super Triple Standard Air Blade™ Ionizer plus ENC-2 Power Supply
16124	24" Super Triple Standard Air Blade™ Ionizer plus ENC-2 Power Supply
16130	30" Super Triple Standard Air Blade™ Ionizer plus ENC-2 Power Supply
16136	36" Super Triple Standard Air Blade™ Ionizer plus ENC-2 Power Supply
16142	42" Super Triple Standard Air Blade™ Ionizer plus ENC-2 Power Supply
16148	48" Super Triple Standard Air Blade™ Ionizer plus ENC-2 Power Supply
16154	54" Super Triple Standard Air Blade™ Ionizer plus ENC-2 Power Supply
16160	60" Super Triple Standard Air Blade™ Ionizer plus ENC-2 Power Supply
16166	66" Super Triple Standard Air Blade™ Ionizer plus ENC-2 Power Supply
16172	72" Super Triple Standard Air Blade™ Ionizer plus ENC-2 Power Supply

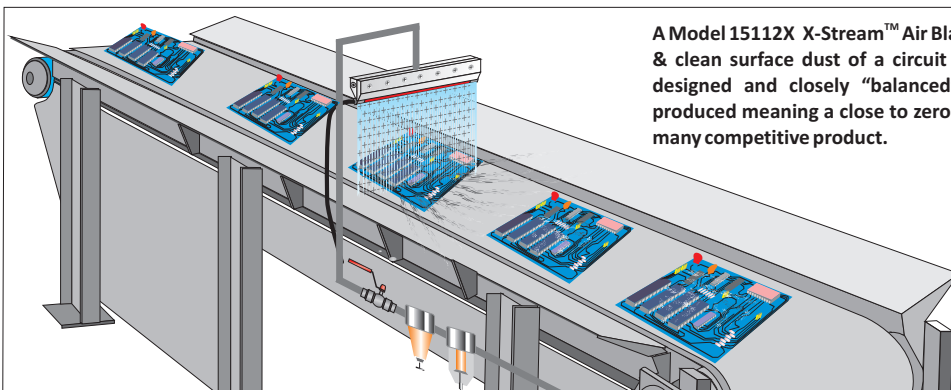

A Model 15112X X-Stream™ Air Blade™ Ionizer is used to neutralize & clean surface dust of a circuit board. The ionizing bar is well designed and closely "balanced" in positive & negative ions produced meaning a close to zero residual charge after use unlike many competitive product.

**STATIC ELIMINATORS**

**ION BLASTER BEAM™ - Quiet, Super Efficient, Concentrated flow of ionized air to eliminate static charge and remove dust!**



**ION BLASTER BEAM™ APPLICATIONS**

- Eliminate static charge and cleaning parts
- Neutralize shrink wrap
- Form fill and seal applications for bag opening
- Neutralizing and cleaning the inside of blow molded parts
- Eliminate static and cleaning of plastic assemblies
- Dust removal from parts prior to painting
- Remove static charge in slitting applications
- Cleaning of packaging
- Neutralization of static charge inside containers

**WHAT ARE THEY - REASONS TO USE**

The *Nex Flow™* Ion Blaster Beam™ neutralizes static electricity and can remove static free dust up to 15 feet (4.6 m) away with no moving parts. It's compact design allows it to be used in hard to reach areas or confined spaces. The air volume and velocity are infinitely adjustable over a wide range using a pressure regulator to address any application from light to heavy duty. The use of an "air amplifier" (Model AM40) maximizes ionized airflow with large volume entrained while minimizing the use of compressed air. (See Air Amplifiers elsewhere in the catalog). In most applications only 10 psig (0.7 bar) is required to operate effectively. The Ionizing Point is a powerful ionizer which remains effective because the air exit "plastic PET head" of the unit prevents weakening if ions which metal attachments may do. This can make the Ion Blaster Beam™ far more effective than systems using metal

**ION BLASTER BEAM™ FEATURES**

- Effective Static Elimination
- Can clean static free dust at a distance
- Compact Design to fit in small spaces
- Stand is pre-drilled for easy mounting

**ION BLASTER BEAM™ BENEFITS**

- Low compressed air use
- Rapid static decay
- Quiet Operation
- Shockless and non-radioactive
- Compact and rugged design
- Intake may be ducted to bring in atmospheric air from another area
- no moving parts and minimal maintenance
- Variable flow and force

**DIMENSIONS**

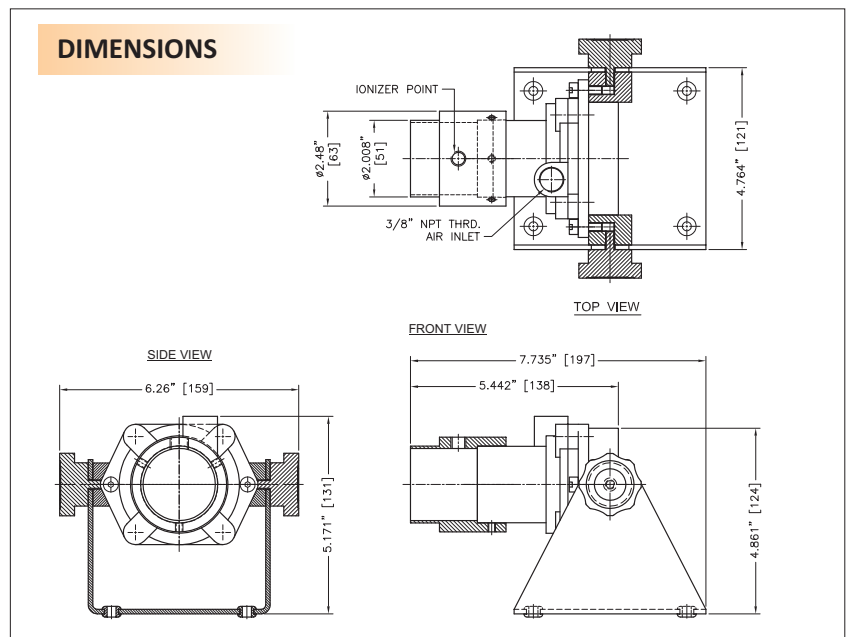

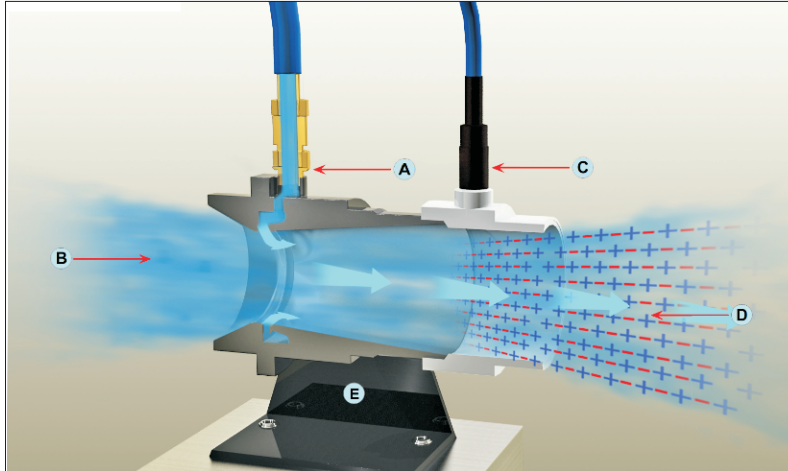

**HOW IT WORKS**

Compressed air is supplied at (A) where it enters the air amplifier section of the Ion Blaster Beam and follows the Coanda profile inside the amplifier. Ambient air is entrained at (B) into the amplifier. The Ionizing Point (C) ionizes the amplified airflow exiting as a powerful high flow of static removing, ionized air ay (D). Unit is mounted on a stand (E) for convenient installation.

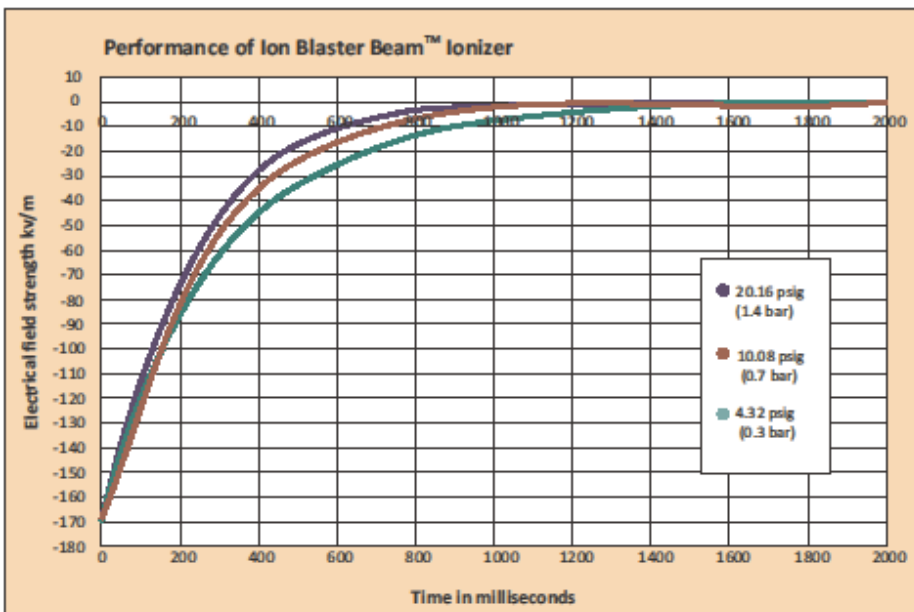

**STATIC ELIMINATORS**

PART NO.	DESCRIPTION
17040	Ion Blaster Beam™ includes Air Amplifier, Spot Ionizer. Stand and 2 Meters shielded cable.
17140	Ion Blaster Beam™ and Power Supply
17340	Ion Blaster Beam™ Kit (c/w Ion Blaster Beam™, Power Supply, Model 90001 water removal filter and Model 90008 regulator wi. gage
80111	120 V Power Supply, 2 outlet
80121	230V Power Supply, 2 outlet
80112	120 V Power Supply, 4 outlet
80122	230 V Power Supply, 4 outlet
90001	Water Removal Filter c/w auto Drain
90008	Water Removal Filter c/w auto Drain

**ION AIR BLASTER BEAM™ SPECIFICATIONS**

**Certification:** North American Power Supplies certified to UL and CSA standards and Spot Ionizer used with the Ion Blaster beam is included with the certification. European Power Supplies CE approved and Spot Ionizer used with the Ion Blaster Beam is included with the certification. Stainless steel emitters on the ionizer.

**Electrical:** For use with 7 kV rms, 5 milliamperes (max) power supply which will last much longer than 5 kv power supplies.

**Electrical Hazard:** Shockless (less or eualt to 5mA)

**Maximum Ambient Temperature:** 122 degrees F or 50 degrees C.

**THE LG LIGHT-WEIGHT ERGONOMETRIC DESIGNED IONIZING AIR GUN IS EFFICIENT AND REPAIRABLE**

**THE LG “LIGHT-WEIGHT GUN” IONIZING AIR GUN**

The LG ionizing Air Gun is light weight at only 16 oz (480 gm) (before air hose and high voltage cable) and easy to handle. If damaged it is easily repairable by replacing one of only seven parts.

**Ionizing Air Gun Function**

The head of the device is enclosed by a sheet material shield, which serves both as mechanical protection and counter-electrode. Due to the special shape of this shield, bypass channels are created, which assist an efficient six-channel blowing nozzle by stabilizing the airflow. The airflow can be adjusted exactly in accordance to the application - particularly useful for the treatment of small pieces.



**Ionizing Air Gun Special Features and Advantages**

- ▶ **Operating facility** : The LG Gun consists of few individual modules, each of which is exchangeable. The high-voltage cable can be extended, shortened or exchanged.
- ▶ **Ergonomic** : Modern industrial design well thought-out down to the last detail. This device can be used conveniently and efficiently by left and right handed persons.
- ▶ **Efficient Air Amplification** : The utilization of the intake air through bypass channels
- ▶ **Lightweight and quiet** : The LG creates remarkably little noise and its low weight makes it easy to handle.

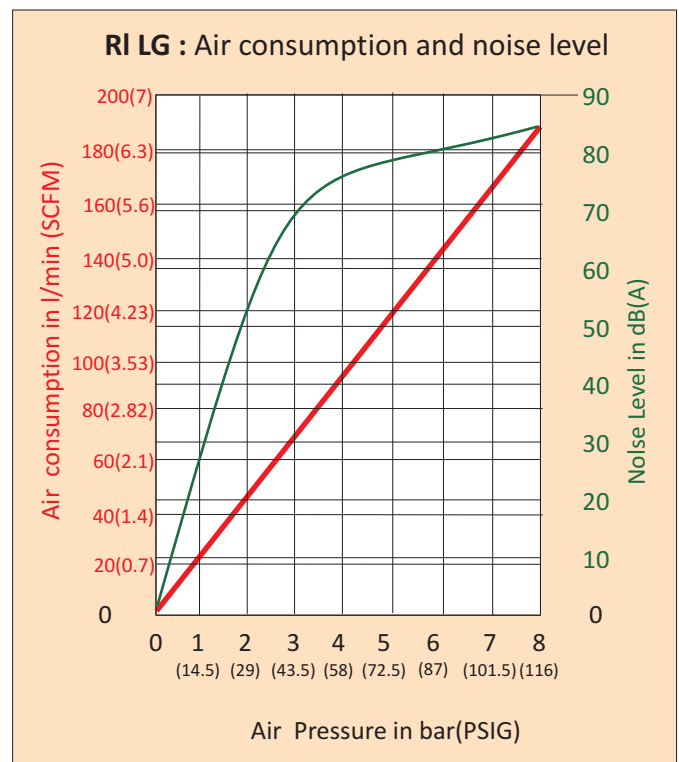

**SPECIAL NOTES:**

The LG Gun as all Haug products, all come with a patented connector to assure safety in operation and maintenance. Field repairable, it prevents a connection if the static gun is removed or attached while power is still on at the power supply. Lightweight and highly flexible cable is FULLY SHIELDED for longer life.

**REPAIRABLE POWER SUPPLIES**

Power supplies are repairable and come with a 2 year warranty.



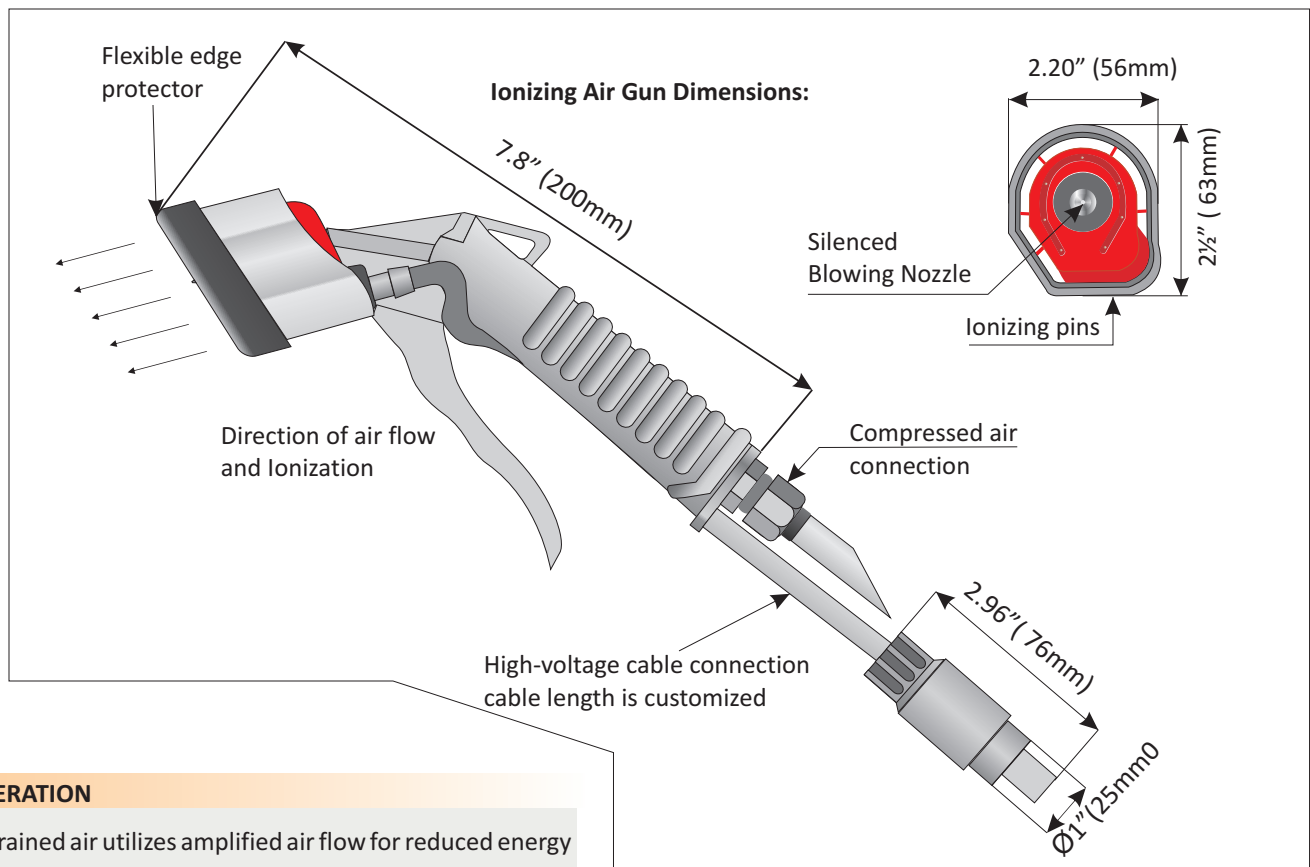
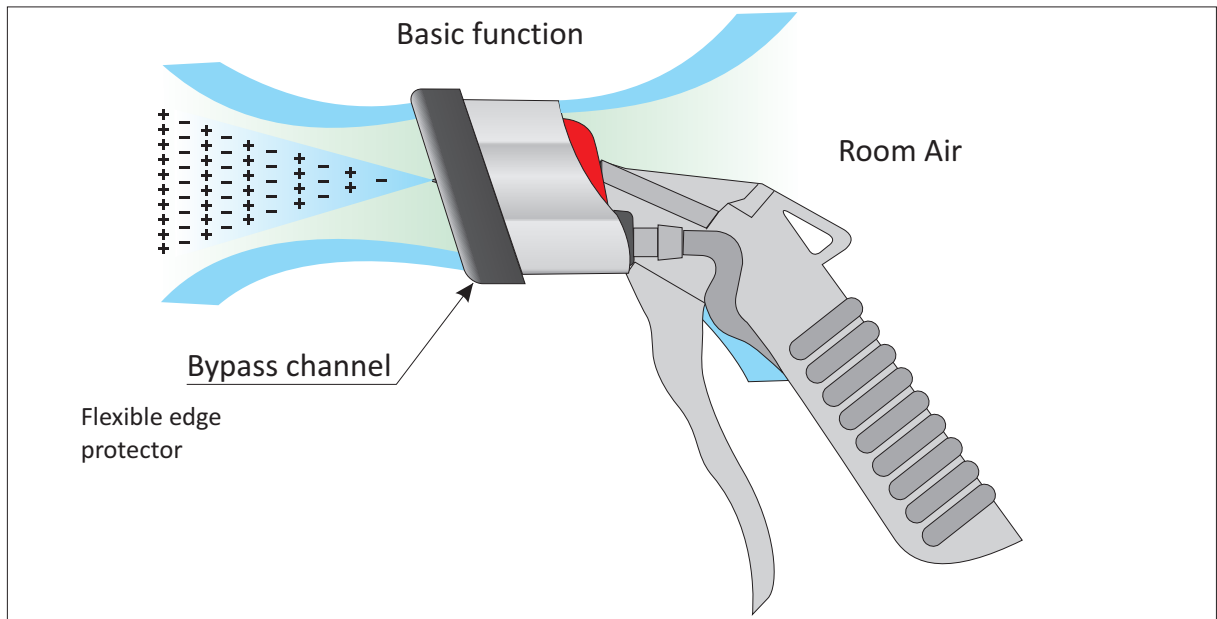

**OPERATION**

Entrained air utilizes amplified air flow for reduced energy use. The Ionizing pins are not in the direct path of the airflow minimizing dirt buildup and preventing premature failure that can occur with pins directly in the path of the air flow.

PART NO.	DESCRIPTION
18001	LG IONIZING GUN ONLY c/w 15 feet of cable
18101	LG IONIZING GUN c/w 15 feet of cable Plus ENC-2 Power Supply (2 outlet)

**STATIC ELIMINATORS**

**Ionizing Nozzles**

The **Ring Ionizer - Ionizing Nozzles** are a highly effective the discharging and cleaning of surfaces - in particular of non-conductive materials. The Nozzles can also be mounted to a handgun if they need to be converted to manual use.

**Ring Ionizer Model 17200 and Model 17203 (with Air Gun) This “mini”**

version is particularly suited for the discharge of very small areas and components in confined work spaces. It is light, flexible and easy to handle, and its robust design makes this unit the lonizer of choice for many discharge processes.

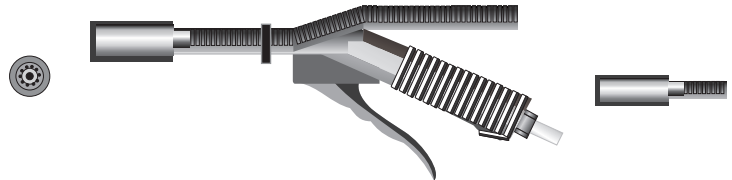

**Ring Ionizer Model 17195 and Model 17196 (with Air Gun)**

This ring ionizer is light, robust and easy to handle with ergonomic design when used with an Air Gun.



**Ring Ionizer Model 17194 and Model 17187 (with Air Gun)**

The largest Nozzle, very heavy duty and robust for larger area applications.

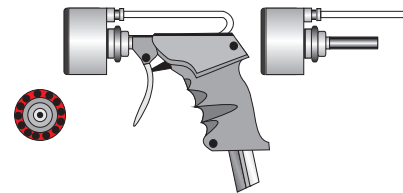

**TECHNICAL DATA**

Model No.	17200 / 17203	17195 / 17196	17194 / 17187
Nozzle Size	Ø 0.8" (20 mm)	Ø 1.3" (32mm)	Ø 2.5" (65mm)
Weight With air gun But no air hose	Ø 0.1" (2mm) Sollid Stream nozzle	3 X Ø 0.1"(1.6mm) Solid Stream nozzle exchangeable	Ø 0.1" (2mm) Flat get nozzel exchangeable
	0.44 pounds(0.2kg)	0.88 pounds (0.4kg)	1.32 pounds (0.6kg)
Weight With air gun But no air hose	1.1 pound (0.5kg)	1.32 pounds (0.6kg)	2.2 pound (1.0kg)
Air Consumption	According to table depending on pressure		
Optimum pressure	Approx.3bar (43.5 psig)		
Operating temperature	-4°F (-20+°c) to122°F (+50°c)		

**STATIC ELIMINATORS - IONIZING NOZZLES**

PART NO.	DESCRIPTION
17200	20 mm (0.8 inches) RING IONIZER NOZZLE /w 6 feet (2 m) cable
17203	20 mm (0.8 inches) RING IONIZER NOZZLE /w 6 feet (2 m) cable with air gun
17195	32mm (1.3 inches) RING IONIZER NOZZLE /w 6 feet (2 m) cable
17196	32 mm (1.3 inches) RING IONIZER NOZZLE /w 6 feet (2 m) cable with air gun
17194	65 mm (2.5 inches) RING IONIZER NOZZLE /w 6 feet (2 m) cable
17187	65 mm (2.5 inches) RING IONIZER NOZZLE /w 6 feet (2 m) cable with air gun

**ONE POINT IONIZER:**

The **One-Point-Ionizer OPI** was developed for the neutralization of tiny parts. This Ionizer is perfectly suited for mounting in places where there is little room. The plug of the electrode must simply be connected to the power supply and the unit can be quickly set into operation without tools.

The One-Point-Ionizer **OPI** has proven its value repeatedly in daily use, e.g. in the medical industry. The **OPI** can also be equipped with compressed air (Mini-Jet Ionizer).

**NOTE:** The pin carries high voltage and must not be touched while in operation.

**DIMENSIONS:**

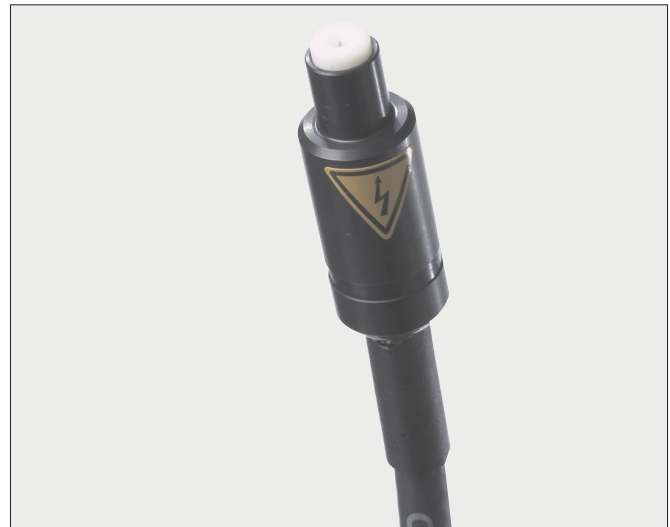
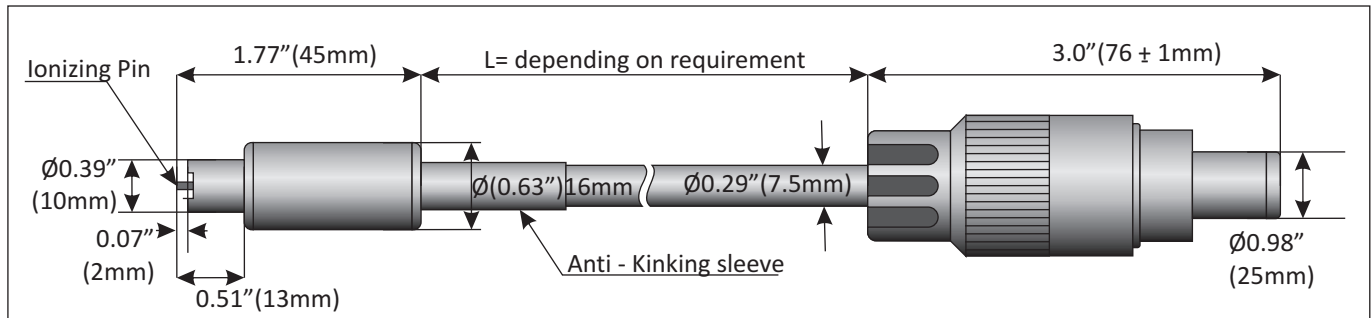

**TECHNICAL:**

TYPE	OPI INSEPARABLE HV-CABLE, ATTACHED PERMANENTLY TO THE BAR
Diameter	0.63" (16 mm)
Length	1.77" (45 mm)
Operating temperature	41°F to 122°F (+5°C to +50°C)
Optimum effective distance	1.18" (30 mm)
Smallest bending radius (cable)	R 50

**MINI JET IONIZER:**

The Haug Mini Jet Ionizer neutralizes electrostatic spot charges with air support, great efficiency and right force over a small flat area. This unit proves its efficiency especially in mounting places where there is little room or where mounting is very complicated. Applications include injection molding for the elimination of material particles or for cleaning of pendants. It encompasses the use of the One Point Ionizer with a flat plastic Nozzle.

PART NO.	DESCRIPTION
17510	ONE POINT SPOT IONIZER c/w 6 feet (2 meters) cable.
17610	MINI-JET IONIZER (JET + ONE SPOT ASSEMBLED)



**STATIC ELIMINATORS**



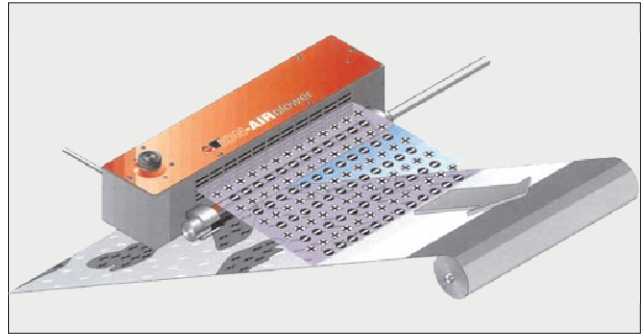
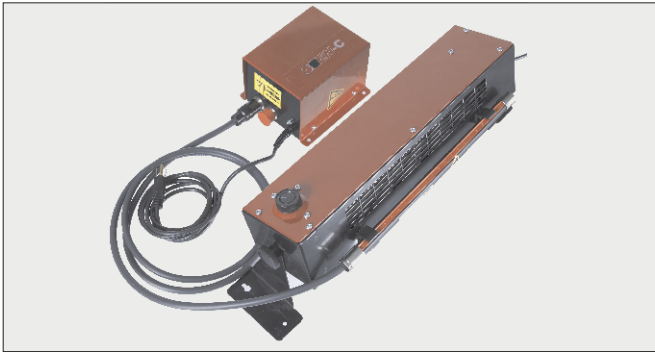

**Ion Blowers:**

Where air is required to affect static removal at a distance, and blowoff force is not required, and compressed air is not available but there is adequate space, the Ion Blower can be used with either the standard Model RN static bar or the extra powerful Model VS bar. These units are easy to mount and simple to operate with an adjustable fan. The bar is located outside the blower for easy maintenance and cleaning. Three different sizes are available - small, medium and large lengths.

Either the standard strength Model RN static bar is supplied and for difficult highly charged surfaces the extra strength Model VS bar is used.

**Applications:**

- ▶ On Winding and Unwinding Systems (especially for Films and Foil) on Injection Molds and their handling systems
- ▶ In the production of circuit boards
- ▶ In the electronic Industry
- ▶ In the plastics and packaging industry

The Ion Air Blower becomes very flexible when a larger operating length is required. Several Units can be 'daisy-chained' in series. In this case, only one Ionizing Bar and one Power Supply is required.

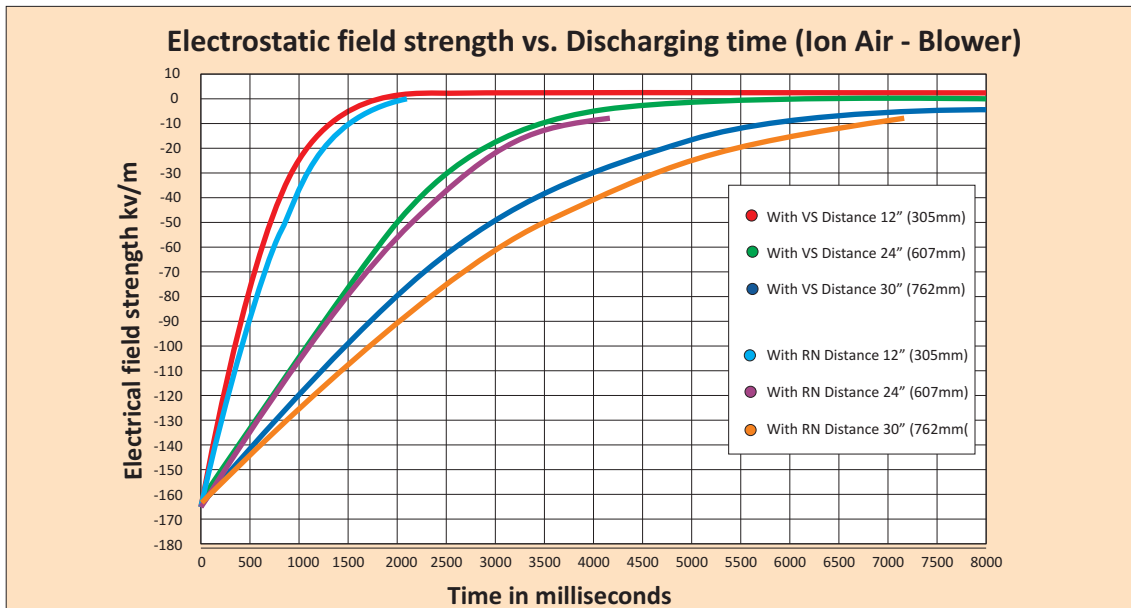
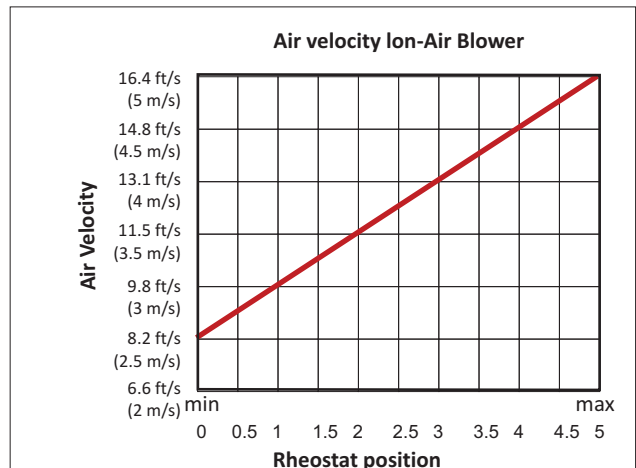

Technical Specifications Ion-Air blower	
Size	Unit with 2 retaining holders, with adjustable screws and base
Length A	Length 18" (457 mm), weight 2.7 kg (5.95lb) max. bar length 14.96" (380 mm)
Length B	Length 32" (813mm), weight 3.6 kg (7.93lb) max. bar length 30.70" (780 mm)
Length C	Length 61.37" (1549 mm), weight 7.0 kg (15.43lb) max. bar length 59.4" (1510 mm)
Rated supply voltage	115 V / 230 V
Rated frequency	50-60 Hz

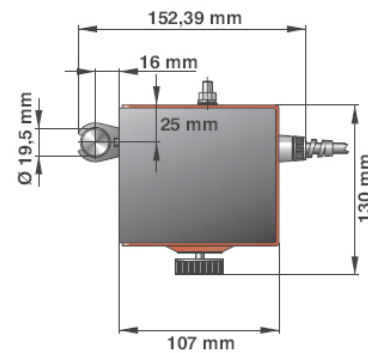
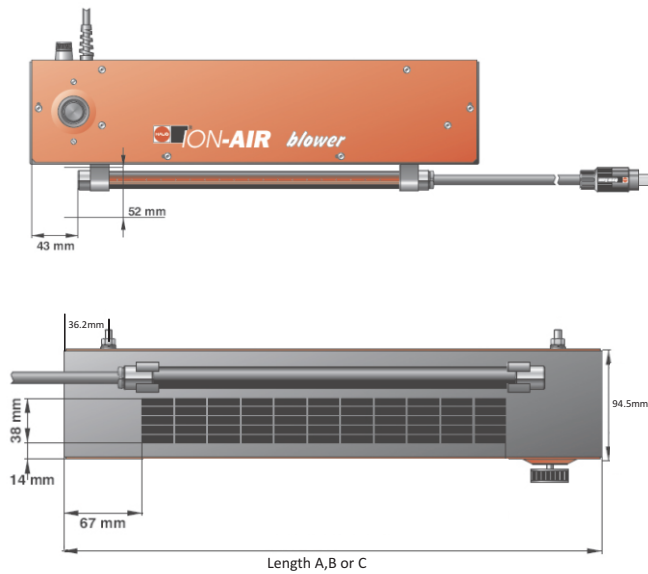

(Mounting Brackets not shown)

**ION BLOWERS - when compressed air is NOT an option**

PART NO.	DESCRIPTION
17001	Small blower 18" (457mm) c/w standard RN static bar & ENC power supply, 110V
17002	Medium blower 32" (813mm) c/w standard RN static bar & ENC power supply, 110V
17003	Large blower 60" (1549mm) c/w standard RN static bar & ENC power supply, 110V
17004	Small blower 18" (457mm) c/w standard RN static bar & ENC power supply, 220V
17005	Medium blower 32" (813mm) c/w standard RN static bar & ENC power supply, 220V
17006	Large blower 60" (1549mm) c/w standard RN static bar & ENC power supply, 220V
17011	Small blower 18" (457mm) c/w super triple VS static bar and ENC power supply, 110V
17012	Medium blower 32" (813mm) c/w super triple VS static bar and ENC power supply, 110V
17013	Large blower 60" (1549mm) c/w super triple VS static bar and ENC power supply, 110V
17014	Small blower 18" (457mm) c/w super triple VS static bar and ENC power supply, 220V
17015	Medium blower 32" (813mm) c/w super triple VS static bar and ENC power supply, 2200V
17016	Large blower 60" (1549mm) c/w super triple VS static bar and ENC power supply, 220V

**Static Testing:**



Multicheck Model 80301 -tests if static bars and power supplies are working. The high-voltage test unit Multicheck is a performance testing unit for any power supply and for HAUG ionization units. Unlike cheap AC Testers which only show if power is going into power supplies or static bars, the Multicheck actually indicates if a power supply or bar is working. As you get close to the static bar, or power supply, a red light goes on indicating power to the unit, then if there is adequate voltage to make the system work, the light goes green. A minimum voltage of 3600 volts is required to insure that a static elimination system is working. The Multicheck light will turn green if you have that voltage. AC Testers will NOT do this and are not an adequate indicator so be wary of marketing ploys which may offer AC testers as an accurate device for testing power supplies or static bars.

For testing power packs, the red measuring probe is inserted into the high-voltage socket as far as it will go. After pressing the red push button the LED will illuminate green if the unit functions correctly. In case of malfunction, the LED will illuminate in red or no display at all is visible

For testing ionizing units the test unit is moved vertically towards the ionizing tips. The LED will flash red; when the probe makes contact, the LED will illuminate in green if the ionizing unit functions correctly.



Hand Held Static Meter Model 80302 - used to indicate static charge on parts, sheets and webs. The Hand Held "Static Control" meter is reasonably priced and easy to handle. It is operated using an ON/OFF soft key (with circuit-breaker) and two further soft keys for the 0-100 and 0-1000 kV/m measuring ranges. The meter is battery powered. It should be part of any basic equipment of every electrical engineering workshop. It is rugged and durable for use in all types of plants operations.



Hand Held Static 1 Digital Static Meter Model 80303 - The Static 1 is a small hand-held field strength meter with digital display for measuring electrostatic charges in Volts and is used if more accurate readings are required than with the standard hand held meter. In order to obtain optimum results, the distance between test object and sensor head - depending on the degree of charge and the condition of the objects' surface - can be selected incrementally. The device is equipped with a Hold function to keep the measured value stored on the display. The integrated micro-computer automatically converts the measured field strength into the equivalent charge in Volt.

**Static Meters**

PART NO.	DESCRIPTION
80301	Multicheck Unit to test if bars and power supplies working
80302	Hand Held Static Meter
80303	Hand Held Static 1 Digital Static Meter



## RING VAC™

Convey solid materials, waste, trim, small parts with virtually no moving parts

### WHAT ARE THEY - REASONS TO USE

The Ring Vac™ - Pneumatic Conveying System has virtually no moving parts, conveys material at high rates and over long distances. They utilize only compressed air for a powerful, efficient venturi action along its length in a compact design for high capacity conveying over large distances. Ring Vacs are available in both coated aluminum or stainless steel. Simply clamp a standard hose size to each end of the Ring Vac™ to create this high energy conveying system. Threaded versions may be connected into standard pipe thread. No moving parts for maintenance free operation with capacity and flow controlled with a pressure regulator. Sizes are 3/8" (10mm), 1/2" (13mm), 3/4" (19mm), 1" (24.4mm), 1-1/4" (32mm), 1-1/2" (38mm) and 2" (51mm) and 3" (76.2mm). Any size beyond that can be prohibitive for most applications due to high compressed air requirements.

Beyond 3", the vacuum ability begins to drop significantly except for highly intermittent applications. However 3" units are available for such applications. Larger sizes are available on special order.

Anodized aluminum and high temperature stainless steel Ring Vac™ air conveyor can convey all types of solids in large volumes over great distances with no moving parts.

### APPLICATIONS:

- ▶ Hopper Loading
- ▶ Material Conveying
- ▶ Trim Removal
- ▶ Transfer Parts
- ▶ Filling Operations
- ▶ Thread/fiber Tensioning

### RING VAC™ BENEFITS:

- ▶ Longer life in difficult environments than competitive models.
- ▶ Ease of use.
- ▶ Simple and easy control of material flow.
- ▶ Maintenance free operation.

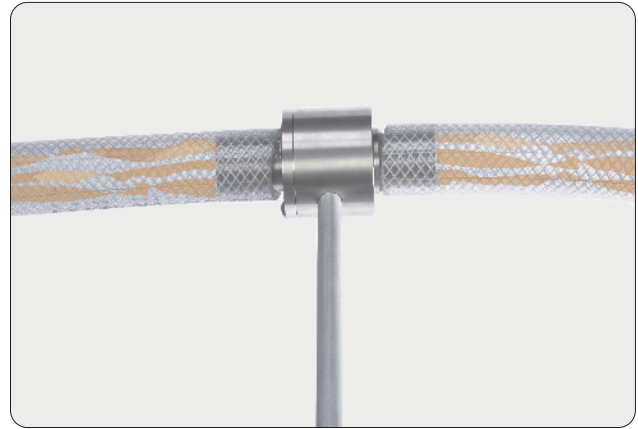

### RING VAC™ FEATURES:

- ▶ Made of anodized aluminum with no moving parts. Regular and high temperature stainless steel models are available for higher temperature and corrosive environments.
- ▶ Standard sizes to fit standard hose diameter for easy clamping. Threaded versions connect easily to regular pipe thread : 1" (25mm), 1-1/4" (32mm), 1-1/2" (38mm), 2" (51mm). Special sizes can be manufactured if required.
- ▶ Utilizing a pressure regulator will control the flow material.
- ▶ Instant on/off with no moving parts, no electricity or explosion hazard.

A Model 30004S Stainless Steel 2" Ring Vac™ Air operated conveyor moves dried peas at a pet food manufacturing facility.

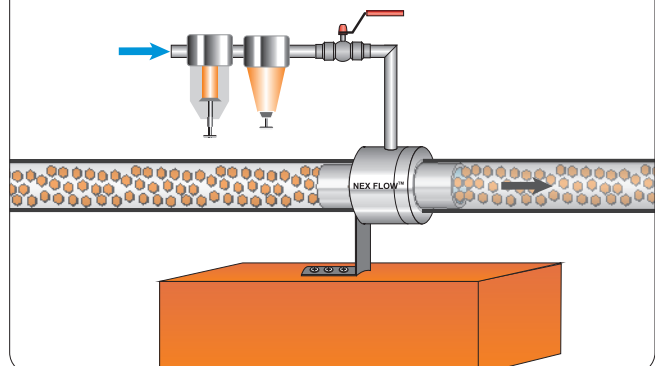

**TYPES OF RING VACS**

The Ring Vac™ Pneumatic Conveying System is available in anodized aluminum, 303/304 stainless steel and in 316L stainless steel. Our special high temperature stainless version is rated to 1200°F (649°C)

Regular models connect to a standard hose or tube to provide a powerful and simply in-line conveying system. Threaded versions thread directly into threaded pipe.

Special materials can be utilized for unique applications. If greater conveying force is required the conveying “generator” can be machined for higher capacities although they will use more compressed air.

An optional bracket allows for easy mounting.



**SELECTION**

The Ring Vac™ is available in a wide variety of sizes depending on your application. There are certain criteria to determine the size you need:

- ▶ Diameter of the parts that need to be conveyed
- ▶ Rate required for conveying (by weight or volume)
- ▶ Diameter of the tube, pipe or hose used
- ▶ Material- Aluminum, stainless or high temperature (To 1200°F (650°C)) stainless
- ▶ Hose connection with clamp or threaded unit

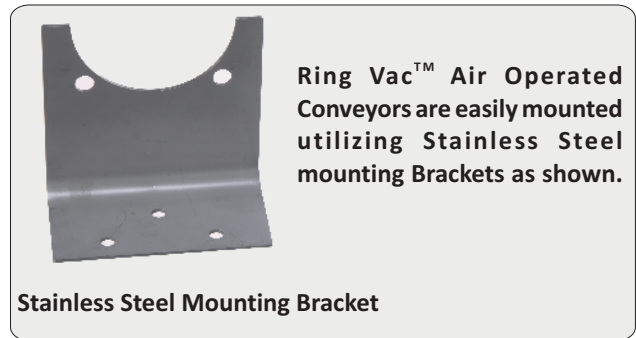

**SPECIAL DESIGNS**

The high temperature models are suited to temperatures up to 1200°F (650°C). One ideal use is for sampling flue gases. Special versions can be supplied with medical flanges, and specific materials, higher flow rates and vacuum depending on your application.

**RING VAC™ - HOW IT WORKS:**

Ring-Vac™ compressed air conveying system - Compressed air enters at point (A) into a annular plenum chamber and injected into the throat of the unit through directed nozzles. These jets of compressed air create a vacuum at the inlet (C) which draws in material and accelerates it through the unit and out at (D) conveying the material over a great vertical or horizontal distance.

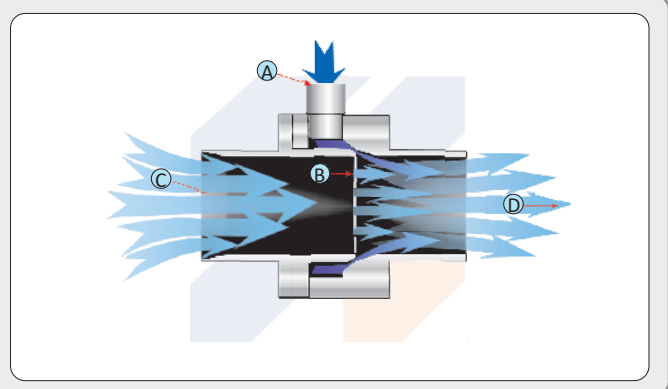

### DIMENSIONS - NOTES ON PART NUMBERS:

**S** - stainless      **TS** - threaded stainless      **THTS** - high temperature threaded stainless  
**T** - threaded      **HTS** - high temperature stainless

Dimensions in inches and (mm)

PART NUMBER (aluminum & stainless)	A IN (MM)	B IN (MM)	C IN (MM)	D IN (MM)	E IN (MM)	F IN (MM)	G IN (MM)	H IN (MM)	I IN (MM)	J IN (MM)	K IN (MM)	L
39998, 39998S 39998HTS	0.375" (10.0)	0.63" (16.0)	0.63" (16.0)	2.18" (65.0)	1.00" (25.0)	0.19" (5.0)	-	-	-	-	-	1/8" NPT
39999, 39999S 39999HTS	0.50" (13.0)	0.75" (19.0)	0.75" (25.4)	2.62" (19.0)	1.25" (32.0)	0.31" (8.0)	-	-	-	-	-	1/8" NPT
30000, 30000S, 30000HTS, 30000S-316L, 30000HTS-316L	0.75" (19.0)	1.00" (25.4)	1.00" (25.4)	3.94" (100.0)	1.95" (49.5)	0.55" (14.0)	1.92" (48.73)	0.95" (15.0)	0.39" (10.0)	1.18" (30.0)	1.97" (50.0)	1/4" NPT
30001, 30001S, 30001T 30001TS, 30001HTS 30001THTS, 30001S-316L 30001HTS-316L	1.00" (25.4)	1.38" (35.1)	1.50" (38.1)	4.88" (124.0)	2.24" (56.8)	0.75" (19.0)	2.17" (55.0)	0.73" (18.5)	0.39" (10.0)	1.58" (40.0)	1.97" (50.0)	1/4" NPT
30002, 30002S, 30002T 30002TS, 30002HTS 30002THTS, 30002S-316L 30002HTS-316L	1.25" (31.8)	1.38" (35.1)	1.50" (38.1)	4.88" (124.0)	2.49" (63.2)	1.00" (25.4)	2.21" (56.3)	0.73" (18.5)	0.39" (10.0)	1.77" (45.0)	2.17" (55.0)	1/4" NPT
30003, 30003S, 30003T 30003TS, 30003HTS 30003THTS, 30003S-316L 30003HTS-316L	1.50" (38.1)	1.38" (35.1)	1.50" (38.1)	4.88" (124.0)	2.75" (69.9)	1.125" (28.6)	2.15" (54.5)	0.89" (22.5)	0.39" (10.0)	1.58" (40.0)	1.97" (50.0)	3/8" NPT
30004, 30004S, 30004T 30004TS, 30004HTS 30004THTS, 30004S-316L 30004HTS-316L	2.00" (50.8)	1.38" (35.1)	1.50" (38.1)	4.88" (124.0)	3.21" (81.6)	1.75" (44.5)	2.39" (60.7)	1.18" (30.0)	0.39" (10.0)	1.58" (40.0)	1.97" (50.0)	3/8" NPT
30005, 30005S 30005HTS	2.50" (63.5)	1.38" (35.1)	1.50" (38.1)	5.29" (134.5)	3.94" (100.0)	2.19" (55.6)	-	-	-	-	-	3/8" NPT
30006, 30006S 30006TS, 30006HTS 30006THTS	3.0" (76.2)	1.58" (40.0)	1.58" (40.0)	5.59" (142.0)	4.33" (110.0)	2.68" (68.0)	-	-	-	-	-	1/2" NPT

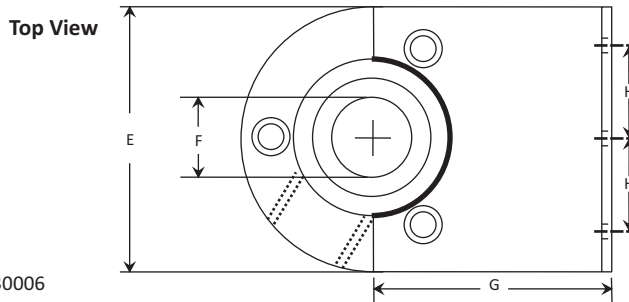

Series 30000 - 30006  
Series 30001S - 30004S

Series 30001T - 30004T Threaded  
Series 30001TS - 30004TS Threaded

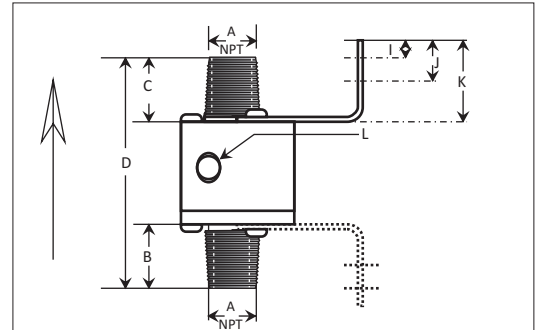
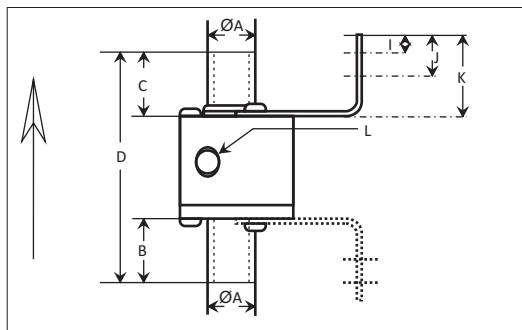

## RING VAC™ PNEUMATIC CONVEYING SYSTEM PERFORMANCE:

MODEL	SIZE OUTSIDE DIAMETER INCHES (MM)	AIR CONSUMPTION SCFM AT 80 PSIG (SLPM AT 5.5 BAR)	VACUUM INCHES H2O (KPA)
39998/39998S/39998HTS	3/8" (10mm)	5.6 (158)	-120 (-29.9)
39999/39999S/39999HTS	1/2" (13mm)	7 (198)	-100 (-24.9)
30000/30000S/30000HTS	3/4" (19mm)	11 (303)	-72 (-18.0)
30000S-316L/30000HTS-316L			
30001/30001S/30001T/30001TS	1" (25mm)	15 (415)	-42 (-11)
30001HTS/30001THTS			
30001S-316L/30001HTS-316L			
30002/30002S/30002T/30002TS	1 1/4" (32mm)	26 (730)	-42 (-11)
30002SHTS/30002HTS			
30002S-316L/30002HTS-316L			
30003TS/30003THTS/30003HTS	1-1/2" (38mm)	33 (932)	-39 (-9)
30003THTS/30003S-316L/30003HTS-316L			
30004/30004S/30004T/30004TS	2" (51mm)	45 (1270)	-28 (-7)
30004HTS/30004THTS			
30004S-316L/30004HTS-316L			
30005/30005S/30005HTS	2-1/2" (63.5mm)	58.5 (1655)	-23.5 (-6)
30006/30006S/30006TS	3" (76mm)	69 (1940)	-14.7 (-4)
30006HTS/30006THTS			

## RING VAC™ IN-LINE CONVEYERS: ALUMINUM RING VACS

PART NO.	DESCRIPTION
39998	3/8" Aluminum Ring Vac Only
39999	1/2" Aluminum Ring Vac™ Only
30000	3/4" Aluminum Ring Vac Only
30001	1" Aluminum Ring Vac™ Only
30002	1-1/4" Aluminum Ring Vac™ Only
30003	1-1/2" Aluminum Ring Vac™ Only
30004	2" Aluminum Ring Vac™ Only
30005	2-1/2" Aluminum Ring Vac™ Only
30006	3" Aluminum Ring Vac™ Only
31998	3/8" Aluminum Ring Vac™ Plus Filter with Auto Drain
31999	1/2" Aluminum Ring Vac™ Plus Filter with Auto Drain
31000	3/4" Aluminum Ring Vac™ Plus Filter with Auto Drain
31001	1" Aluminum Ring Vac™ plus Filter with Auto Drain
31002	1-1/4" Aluminum Ring Vac™ plus Filter with Auto Drain
31003	1-1/2" Aluminum Ring Vac™ plus Filter with Auto Drain
31004	2" Aluminum Ring Vac™ plus Filter with Auto Drain
31005	2-1/2" Aluminum Ring Vac™ Plus Filter with Auto Drain
31006	3" Aluminum Ring Vac™ Plus Filter with Auto Drain
32998	3/8" Aluminum Ring Vac Plus Filter with Auto Drain and Regulator with Gauge
32999	1/2" Aluminum Ring Vac Plus Filter with Auto Drain and Regulator with Gauge
32000	3/4" Aluminum Ring Vac Plus Filter with Auto Drain and Regulator with Gauge
32001	1" Aluminum Ring Vac™ plus Filter with Auto Drain & Regulator with Gauge
32002	1-1/4" Aluminum Ring Vac™ plus Filter with Auto Drain & Regulator with Gauge
32003	1-1/2" Aluminum Ring Vac™ plus Filter with Auto Drain & Regulator with Gauge
32004	2" Aluminum Ring Vac™ plus Filter with Auto Drain & Regulator with Gauge
32005	2-1/2" Aluminum Ring Vac™ Plus Filter with Auto Drain and Regulator with Gauge
32006	3" Aluminum Ring Vac™ Plus Filter with Auto Drain and Regulator with Gauge
30001T	1" Threaded Aluminum Ring Vac™ Only
30002T	1-1/4" Threaded Aluminum Ring Vac™ Only



**RING VAC™ IN-LINE CONVEYERS : ALUMINUM RING VACS (CON'T)**

PART NO.	DESCRIPTION
30003T	1-1/2" Threaded Aluminum Ring Vac™ Only
30004T	2" Threaded Aluminum Ring Vac™ Only
31001T	1" Threaded Aluminum Ring Vac™ plus Filter with Auto Drain
31002T	1-1/4" Threaded Aluminum Ring Vac™ plus Filter with Auto Drain
31003T	1-1/2" Threaded Aluminum Ring Vac™ plus Filter with Auto Drain
31004T	2" Threaded Aluminum Ring Vac™ plus Filter with Auto Drain
32001T	1" Threaded Aluminum Ring Vac™ & Filter + Auto Drain & Regulator with Gauge
32002T	1-1/4" Threaded Alum. Ring Vac™ & Filter + Auto Drain & Regulator with Gauge
32003T	1-1/2" Threaded Alum. Ring Vac™ & Filter + Auto Drain & Regulator with Gauge
32004T	2" Threaded Aluminum Ring Vac™ & Filter + Auto Drain & Regulator with Gauge

**RING VAC™ IN-LINE CONVEYERS : STAINLESS STEEL RING-VACS**

PART NO.	DESCRIPTION
39998S	3/8" Stainless Ring Vac™ Only
39999S	1/2" Stainless Ring Vac™ Only
30000S	3/4" Stainless Ring Vac™ Only
30001S	1" Stainless Ring Vac™ Only
30002S	1-1/4" Stainless Ring Vac™ Only
30003S	1-1/2" Stainless Ring Vac™ Only
30004S	2" Stainless Ring Vac™ Only
30005S	2-1/2" Stainless Ring Vac™ Only
30006S	3" Stainless Ring Vac™ Only
31998S	3/8" Stainless Ring Vac™ plus Filter with Auto Drain
31999S	1/2" Stainless Ring Vac™ plus Filter with Auto Drain
31000S	3/4" Stainless Ring Vac™ plus Filter with Auto Drain
31001S	1" Stainless Ring Vac™ plus Filter with Auto Drain
31002S	1-1/4" Stainless Ring Vac™ plus Filter with Auto Drain
31003S	1-1/2" Stainless Ring Vac™ plus Filter with Auto Drain
31004S	2" Stainless Ring Vac™ plus Filter with Auto Drain
31005S	2-1/2" Stainless Ring Vac™ plus Filter with Auto Drain
31006S	3" Stainless Ring Vac™ plus Filter with Auto Drain
32998S	3/8" Stainless Ring Vac™ plus Filter with Auto Drain & Regulator with Gauge
32999S	1/2" Stainless Ring Vac™ plus Filter with Auto Drain & Regulator with Gauge
32000S	3/4" Stainless Ring Vac™ plus Filter with Auto Drain & Regulator with Gauge
32001S	1" Stainless Ring Vac™ plus Filter with Auto Drain & Regulator with Gauge
32002S	1-1/4" Stainless Ring Vac™ plus Filter with Auto Drain & Regulator with Gauge
32003S	1-1/2" Stainless Ring Vac™ plus Filter with Auto Drain & Regulator with Gauge
32004S	2" Stainless Ring Vac™ plus Filter with Auto Drain & Regulator with Gauge
32005S	2-1/2" Stainless Ring Vac™ plus Filter with Auto Drain & Regulator with Gauge
32006S	3" Stainless Ring Vac™ plus Filter with Auto Drain & Regulator with Gauge
30001TS	1" Threaded Stainless Ring Vac™ Only
30002TS	1-1/4" Threaded Stainless Ring Vac™ Only
30003TS	1-1/2" Threaded Stainless Ring Vac™ Only





**RING VAC™ IN-LINE CONVEYERS : STAINLESS STEEL RING-VACS (Con't)**

PART NO.	DESCRIPTION
30004TS	2" Threaded Stainless Ring Vac™ Only
30006TS	3" Threaded Stainless Ring Vac™ Only
31001TS	1" Threaded Stainless Ring Vac™ plus Filter with Auto Drain
31002TS	1-1/4" Threaded Stainless Ring Vac™ plus Filter with Auto Drain
31003TS	1-1/2" Threaded Stainless Ring Vac™ plus Filter with Auto Drain
31004TS	2" Threaded Stainless Ring Vac™ plus Filter with Auto Drain
31006TS	3" Threaded Stainless Ring Vac™ plus Filter with Auto Drain
32001TS	1" Threaded Stainless Ring Vac™ & Filter + Auto Drain & Regulator with Gauge
32002TS	1-1/4" Threaded SS. Ring Vac™ & Filter + Auto Drain & Regulator with Gauge
32003TS	1-1/2" Threaded SS. Ring Vac™ & Filter + Auto Drain & Regulator with Gauge
32004TS	2" Threaded Stainless Ring Vac™ & Filter + Auto Drain & Regulator with Gauge
32006TS	3" Threaded Stainless Ring Vac™ & Filter + Auto Drain & Regulator with Gauge

**RING VAC™ IN-LINE CONVEYERS : HIGH TEMPERATURE STAINLESS STEEL RING VACS**

PART NO.	DESCRIPTION
39998HTS	3/8" High Temperature Stainless Ring Vac™ Only
39999HTS	1/2" High Temperature Stainless Ring Vac™ Only
30000HTS	3/4" High Temperature Stainless Ring Vac™ Only
30001HTS	1" High Temperature Stainless Ring Vac™ Only
30002HTS	1-1/4" High Temperature Stainless Ring Vac™ Only
30003HTS	1-1/2" High Temperature Stainless Ring Vac™ Only
30004HTS	2" High Temperature Stainless Ring Vac™ Only
30005HTS	2-1/2" High Temperature Stainless Ring Vac™ Only
30006HTS	3" High Temperature Stainless Ring Vac™ Only
31998HTS	3/8" High Temperature Stainless Ring Vac™ plus Filter with Auto Drain
31999HTS	1/2" High Temperature Stainless Ring Vac™ plus Filter with Auto Drain
31000HTS	3/4" High Temperature Stainless Ring Vac™ plus Filter with Auto Drain
31001HTS	1" High Temperature Stainless Ring Vac™ plus Filter with Auto Drain
31002HTS	1-1/4" High Temperature Stainless Ring Vac™ plus Filter with Auto Drain
31003HTS	1-1/2" High Temperature Stainless Ring Vac™ plus Filter with Auto Drain
31004HTS	2" High Temperature Stainless Ring Vac™ plus Filter with Auto Drain
31005HTS	2-1/2" High Temperature Stainless Ring Vac™ plus Filter with Auto Drain
31006HTS	3" High Temperature Stainless Ring Vac™ plus Filter with Auto Drain
32998HTS	3/8" High Temp. SS. Ring Vac™ plus Filter + Auto Drain & Regulator with Gauge
32999HTS	1/2" High Temp. SS. Ring Vac™ plus Filter + Auto Drain & Regulator with Gauge
32000HTS	3/4" High Temp. SS. Ring Vac™ plus Filter + Auto Drain & Regulator with Gauge
32001HTS	1" High Temp. SS. Ring Vac™ plus Filter + Auto Drain & Regulator with Gauge
32002HTS	1-1/4" High Temp. SS. Ring Vac™ plus Filter + Auto Drain & Regulator with Gauge
32003HTS	1-1/2" High Temp. SS. Ring Vac™ plus Filter + Auto Drain & Regulator with Gauge



**RING VAC™ IN-LINE CONVEYERS: HIGH TEMPERATURE STAINLESS STEEL RING VACS (Con't)**

PART NO.	DESCRIPTION
32004HTS	2" High Temp. SS. Ring Vac™ plus Filter + Auto Drain & Regulator with Gauge
32005HTS	2-1/2" High Temp. SS. Ring Vac™ plus Filter + Auto Drain & Regulator with Gauge
32006HTS	3" High Temp. SS. Ring Vac™ plus Filter + Auto Drain & Regulator with Gauge
30001THTS	1" High Temperature Threaded Stainless Ring Vac™ Only
30002THTS	1-1/4" High Temperature Threaded Stainless Ring Vac™ Only
30003THTS	1-1/2" High Temperature Threaded Stainless Ring Vac™ Only
30004THTS	2" High Temperature Threaded Stainless Ring Vac™ Only
30006THTS	3" High Temperature Threaded Stainless Ring Vac™ Only
31001THTS	1" High Temp. Threaded SS. Ring Vac™ plus Filter with Auto Drain
31002THTS	1-1/4" High Temp. Threaded SS. Ring Vac™ plus Filter with Auto Drain
31003THTS	1-1/2" High Temp. Threaded SS. Ring Vac™ plus Filter with Auto Drain
31004THTS	2" High Temp. Threaded SS. Ring Vac™ plus Filter with Auto Drain
31006THTS	3" High Temp. Threaded SS. Ring Vac™ plus Filter with Auto Drain
32001THTS	1" High Temp. Threaded SS. Ring Vac™ & Filter + Auto Drain & Regulator with Gauge
32002THTS	1-1/4" High Temp. Threaded SS. Ring Vac™ & Filter + Auto Drain & Regulator with Gauge
32003THTS	1-1/2" High Temp. Threaded SS. Ring Vac™ & Filter + Auto Drain & Regulator with Gauge
32004THTS	2" High Temp. Threaded SS. Ring Vac™ & Filter + Auto Drain & Regulator with Gauge
32006THTS	3" High Temp. Threaded SS. Ring Vac™ & Filter + Auto Drain & Regulator with Gauge
30000S-316L	3/4" 316L Stainless Ring Vac™ Only
30000S-316L	1" 316L Stainless Ring Vac™ Only
30001S-316L	1-1/4" 316L Stainless Ring Vac™ Only
30002S-316L	1-1/2" 316L Stainless Ring Vac™ Only
30003S-316L	2" 316L Stainless Ring Vac™ Only
31000S-316L	3/4" 316L Stainless Ring Vac™ plus Filter with Auto Drain
31001S-316L	1" 316L Stainless Ring Vac™ plus Filter with Auto Drain
31002S-316L	1-1/4" 316L Stainless Ring Vac™ plus Filter with Auto Drain
31003S-316L	1-1/2" 316L Stainless Ring Vac™ plus Filter with Auto Drain
31004S-316L	2" 316L Stainless Ring Vac™ plus Filter with Auto Drain
32000S-316L	3/4" 316L Stainless Ring Vac™ plus Filter with Auto Drain & Regulator with Gauge
32001S-316L	1" 316L Stainless Ring Vac™ plus Filter with Auto Drain & Regulator with Gauge
32002S-316L	1-1/4" 316L Stainless Ring Vac™ plus Filter with Auto Drain & Regulator with Gauge

**RING VAC™ AIR OPERATED CONVEYOR SYSTEMS**

**RING VAC™ IN-LINE CONVEYERS: HIGH TEMPERATURE STAINLESS STEEL RING VACS (Con't)**

PART NO.	DESCRIPTION
32003S-316L	1-1/2" 316L Stainless Ring Vac™ plus Filter with Auto Drain & Regulator with Gauge
32004S-316L	2" 316L Stainless Ring Vac™ plus Filter with Auto Drain & Regulator with Gauge
30000HTS-316L	3/4" 316L High Temperature Stainless Ring Vac™ Only
30001HTS-316L	1" 316L High Temperature Stainless Ring Vac™ Only
30002HTS-316L	1-1/4" 316L High Temperature Stainless Ring Vac™ Only
30003HTS-316L	1-1/2" 316L High Temperature Stainless Ring Vac™ Only
30004HTS-316L	2" 316L High Temperature Stainless Ring Vac™ Only
31000HTS-316L	3/4" 316L High Temperature Stainless Ring Vac™ + Filter with Auto Drain
31001HTS-316L	1" 316L High Temperature Stainless Ring Vac™ + Filter with Auto Drain
31002HTS-316L	1-1/4" 316L High Temperature Stainless Ring Vac™ + Filter with Auto Drain
31003HTS-316L	1-1/2" 316L High Temperature Stainless Ring Vac™ + Filter with Auto Drain
31004HTS-316L	2" 316L High Temperature Stainless Ring Vac™ + Filter with Auto Drain
32000HTS-316L	3/4" 316L High Temp. Stainless Ring Vac™ + Filter with Auto Drain & Regulator with Drain
32001HTS-316L	1" 316L High Temp. Stainless Ring Vac™ + Filter with Auto Drain & Regulator with Drain
32002HTS-316L	1-1/4" 316L High Temp. Stainless Ring Vac™ + Filter with Auto Drain & Regulator with Drain
32003HTS-316L	1-1/2" 316L High Temp. Stainless Ring Vac™ + Filter with Auto Drain & Regulator with Drain
32004HTS-316L	2" 316L High Temp. Stainless Ring Vac™ + Filter with Auto Drain & Regulator with Drain

PART NO.	DESCRIPTION
39000S	Stainless Steel Bracket for 30000, 30000S and 30000HTS
39001S	Stainless Steel Bracket for 30001, 30001T, 30001S, 30001TS, 30001HTS, 30001THTS
39002S	Stainless Steel Bracket for 30002, 30002T, 30002S, 30002TS, 30002HTS, 30002THTS
39003S	Stainless Steel Bracket for 30003, 30003T, 30003S, 30003TS, 30003HTS, 30003THTS
39004S-A	Stainless Steel Bracket for 30004 and 30004T
39004S-S	Stainless Steel Bracket for 30004S, 30004TS, 30004HTS, 30004THTS



## X-STREAM™ RING VAC™

Convey solid materials, waste, trim, small parts with virtually no moving parts further with wear resistance

### WHAT ARE THEY - REASONS TO USE

Conveyors X-Stream™ Ring Vac™ – pneumatic conveying system is similar to the regular Ring Vac™ but with much more power to convey materials much further both vertically and horizontally. In addition they are hard anodized for abrasion resistance to make them last long in moving abrasive, rough materials. As with the regular Ring Vac™ they utilize only compressed air for a powerful, efficient venture i action along its length in a compact design for high capacity conveying over large distances. Simply clamp a standard hose size to each end of the Ring Vac™ to create this high energy conveying system. Threaded versions may be connected into standard pipe thread. No moving parts for maintenance free operation with capacity and flow controlled with a pressure regulator. Sizes are 1" (25mm), 1-1/4" (32 mm), 1-1/2" (38 mm) and 2" (51 mm). Any size beyond that can be prohibitive for most applications due to high compressed air requirements.

Beyond 2", the vacuum ability begins to drop significantly except for highly intermittent applications. For applications beyond 2", a blower system often becomes far more economical except in a rare number of possible applications. However, larger size versions are available on special order. Anodized aluminum and high temperature stainless steel Ring Vac™ air conveyor can convey all types of solids in large volumes over great distances with no moving parts.

### APPLICATIONS:

- ▶ Hopper Loading
- ▶ Material Conveying
- ▶ Trim Removal
- ▶ Transfer Parts
- ▶ Filling Operations
- ▶ Thread/fiber Tensioning

### HEAVY DUTY X-STREAM™ RING VAC™ BENEFITES:

- ▶ Longer life in difficult environments than competitive models.
- ▶ Ease of use.
- ▶ Simple and easy control of material flow.
- ▶ Maintenance free operation.



### HEAVY DUTY X-STREAM™ RING VAC™ FEATURES:

- ▶ Made of Hard Anodized aluminum with no moving parts. Ideal for moving abrasive materials
- ▶ Extra strength to convey longer distances both vertically and horizontally than standard models.
- ▶ Utilizing a pressure regulator will control the flow of material
- ▶ Instant on/off with no moving parts, no electricity or explosion hazard

Heavy Duty X-Stream™ Ring Vac™ Model 30002X transports an abrasive material over 100 feet across a plant floor from one operation to the next

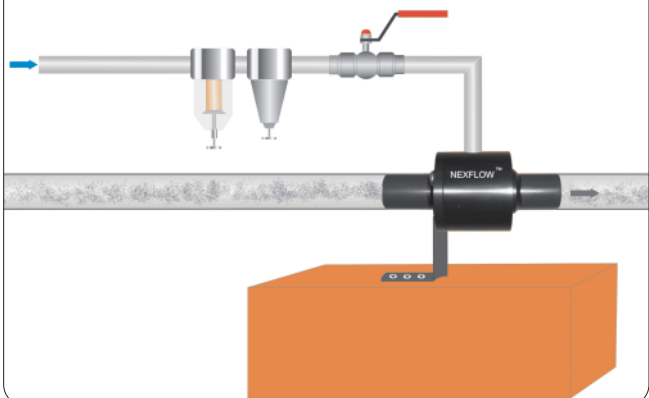

## TYPES OF RING VACS

The Heavy Duty X-Stream™ Ring Vac™ Pneumatic Conveying System comes in hard anodized aluminum for abrasion resistance and with more power than the standard versions to convey greater vertical and horizontal distances. Regular models connect to a standard hose or tube to provide a powerful and simply in-line conveying system. Threaded versions thread directly into threaded pipe.

The generator can be machined further for even larger capacities and distances although they can will use more compressed air.

An optional bracket allows form easy mounting.



Heavy Duty X-Stream™ Ring Vac™ Air Operated conveyor

Threaded Heavy Duty X-Stream™ Ring Vac™ Air Operated conveyor

## SELECTION

The Heavy Duty X-Stream™ Ring Vac™ is available in a wide variety of sizes depending on your application. There are certain criteria to determine the size you need:

- ▶ Diameter of the parts that need to be conveyed
- ▶ Rate required for conveying (by weight or volume)
- ▶ Diameter of the tube, pipe or hose used
- ▶ Material- Hard Anodized Aluminum



Heavy Duty X-Stream™ Ring Vac™ Air Operated Conveyors are easily mounted utilizing Stainless Steel mounting Brackets as shown.

Stainless Steel Mounting Bracket

## SPECIAL DESIGNS

The high temperature models are suited to temperatures up to 1200°F (650°C). One ideal use is for sampling flue gases. Special versions can be supplied with medical flanges, and specific materials, higher flow rates and vacuum depending on your application.

### Heavy Duty X-Stream™ Ring Vac™ - HOW IT WORKS:

Ring-Vac™ compressed air conveying system - Compressed air enters at point (A) into a annular plenum chamber and injected into the throat of the unit through directed nozzles. These jets of compressed air create a vacuum at the inlet (C) which draws in material and accelerates it through the unit and out at (D) conveying the material over a great vertical or horizontal distance.

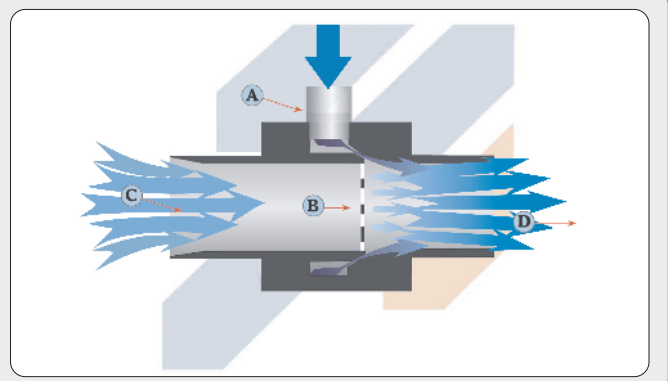

## DIMENSIONS - NOTES ON PART NUMBERS:

T- threaded

Dimensions in inches and (mm)

PART NUMBER (aluminum & stainless)	A IN (MM)	B IN (MM)	C IN (MM)	D IN (MM)	E IN (MM)	F IN (MM)	G IN (MM)	H IN (MM)	I IN (MM)	J IN (MM)	K IN (MM)	L
30001X, 30001XT	1.00" (25.4)	1.38" (35.1)	1.50" (38.1)	4.88" (124.0)	2.24" (56.8)	0.75" (19.0)	2.17" (55.0)	0.73" (18.5)	0.39" (10.0)	1.58" (40.0)	1.97" (50.0)	1/4 NPT
30002X, 30002XT	1.25" (31.8)	1.38" (35.1)	1.50" (38.1)	4.88" (124.0)	2.49" (63.2)	1.00" (25.4)	2.21" (56.3)	0.73" (18.5)	0.39" (10.0)	1.77" (45.0)	2.17" (55.0)	1/4 NPT
30003X, 30003XT	1.50" (38.1)	1.38" (35.1)	1.50" (38.1)	4.88" (124.0)	2.75" (69.9)	1.125" (28.6)	2.15" (54.5)	0.89" (22.5)	0.39" (10.0)	1.58" (40.0)	1.97" (50.0)	3/8 NPT
30004X, 30004XT	2.00" (50.8)	1.38" (35.1)	1.50" (38.1)	4.88" (124.0)	3.21" (81.6)	1.75" (44.5)	2.39" (60.7)	1.18" (30.0)	0.39" (10.0)	1.58" (40.0)	1.97" (50.0)	3/8 NPT

Top View

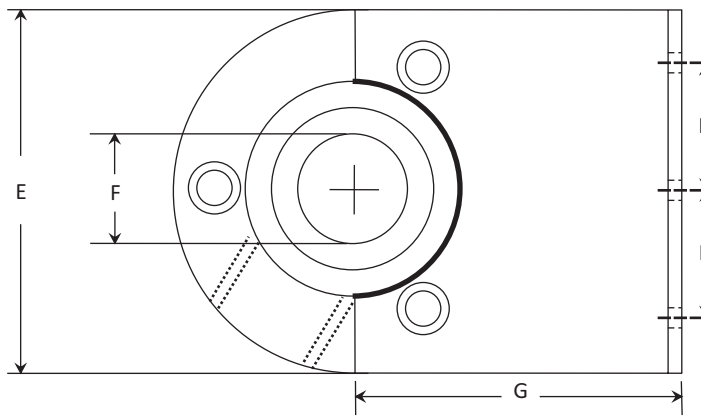

Series 30001X - 30004X

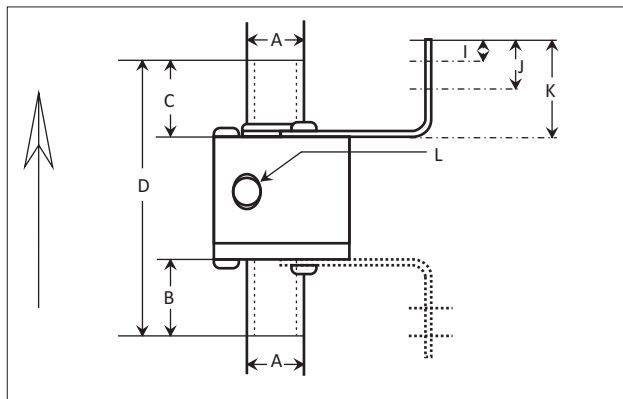

Series 30001XT - 30004XT Threaded

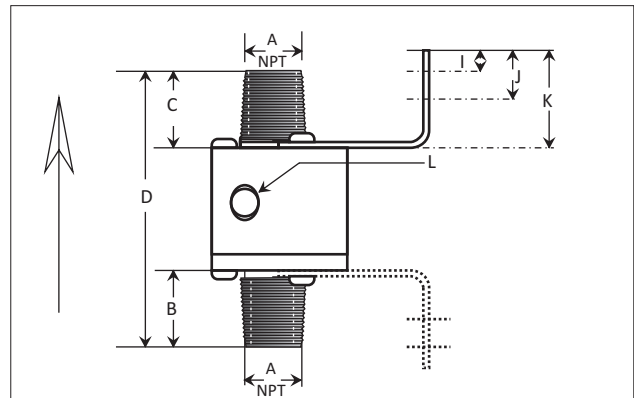

RING VAC™ AIR OPERATED CONVEYOR SYSTEMS



**HEAVY DUTY X-STREAM™ RING VAC™ PNEUMATIC CONVEYING SYSTEM PERFORMANCE:**

MODEL	SIZE OUTSIDE DIAMETER INCHES (MM)	AIR CONSUMPTION SCFM AT 80 PSIG (SLPM AT 5.5 BAR)	VACUUM INCHES H2O (KPA)
30001X, 30001XT	1" (25mm)	21 (595)	-60 (-15)
30002X, 30002XT	1 1/4" (32mm)	33 (934)	-55 (-14)
30003X, 30003XT	1-1/2" (38mm)	44 (1245)	-50 (-13)
30004X, 30004XT	2" (51mm)	58 (1642)	-36 (-9)

**HEAVY DUTY X-STREAM™ RING VAC™ IN-LINE CONVEYERS**

PART NO.	DESCRIPTION
30001X	1" X-Stream™ Ring Vac™ Only
30002X	1-1/4" Aluminum Ring Vac™ Only
30003X	1-1/2" Aluminum Ring Vac™ Only
30004X	2" Aluminum Ring Vac™ Only
31001X	1" Aluminum Ring Vac™ plus Filter with Auto Drain
31002X	1-1/4" Aluminum Ring Vac™ plus Filter with Auto Drain
31003X	1-1/2" Aluminum Ring Vac™ plus Filter with Auto Drain
31004X	2" Aluminum Ring Vac™ plus Filter with Auto Drain
32001X	1" Aluminum Ring Vac™ plus Filter with Auto Drain & Regulator with Gauge
32002X	1-1/4" Aluminum Ring™ Vac plus Filter with Auto Drain & Regulator with Gauge
32003X	1-1/2" Aluminum Ring Vac™ plus Filter with Auto Drain & Regulator with Gauge
32004X	2" Aluminum Ring Vac™ plus Filter with Auto Drain & Regulator with Gauge

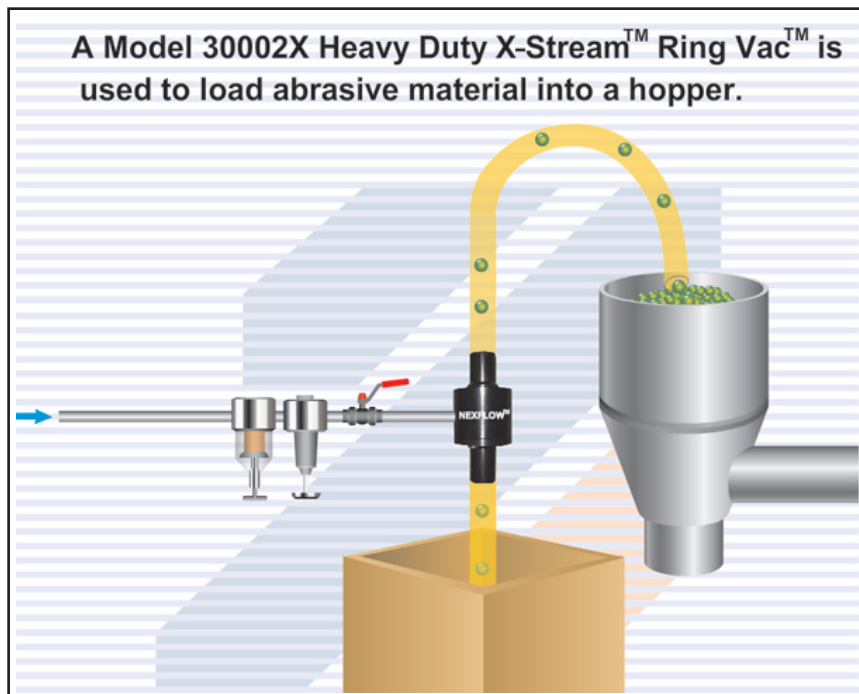

**X-STREAM™ SUPREME PNEUMATIC AIR OPERATED CONVEYOR – (XSPC)**

NON-CLOGGING Powerful Air Operated Conveyor to convey solid materials, waste, trip small parts with no moving parts – straight through design prevents clogging

**WHAT ARE THEY - REASONS TO USE**

The X-STREAM™ SUPREME PNEUMATIC AIR OPERATED CONVEYOR, or XSPC is a pneumatic conveying system based on Ring Vac™ technology but design is such that the flow of material is “straight through” preventing the clogging of materials which may be subject to this in traditional venture systems. Designed for optimum air consumption efficiency but powerful conveying action. Material is hard anodized aluminum. Stainless steel can be provided n special order. Simply clamp a standard hose size to the end of the XSPC to operate this high energy conveying system. No moving parts for maintenance free operation with capacity and flow controlled with a pressure regulator. Sizes are based on internal dimensions: 1” (25mm), 1.25” (31.5 mm), 1.5” (38 mm) and 2” (50 mm) Inside diameters. Special versions can be produced for your applications.

Cleaning of the units is easy as they can be dismantled like the Ring Vac's, cleaned and re-assembled.

**APPLICATIONS:**

- electrical and electronic components
- springs
- packaged goods
- paper and plastic strips
- textiles
- chip removal
- wood chips

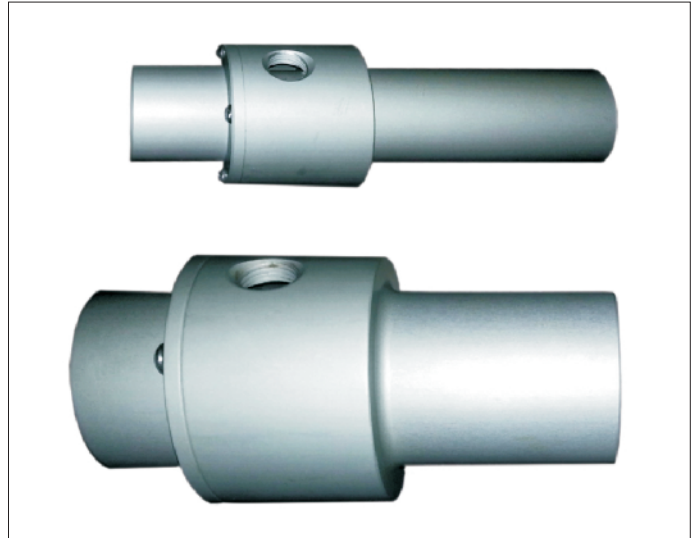

**XSPC FEATURES**

- Made of hard anodized aluminum with no moving parts.
- Standard Sizes to fit standard hose diameter for easy clamping. Special sizes can be manufactured if required.
- Using a pressure regulator will control the flow of material.
- Instant on/off with no moving parts, no electricity or explosion hazard.
- Can be taken apart and cleaned easily.
- Special versions and materials can be made.

**XSPC – HOW IT WORKS:**

The X-stream™ Supreme Pneumatic Conveyor (XSPC) – Compressed air enters at point (A) into an annular chamber and injected into the throat of the unit from the inside wall of the unit through directed nozzles (B). The inside is “straight through” design to prevent any clogging of conveyed material. These jets of compressed air create a vacuum at the inlet (C) which draws in material and accelerates it through the unit and out at (D) conveying the material over a great vertical or horizontal distance.

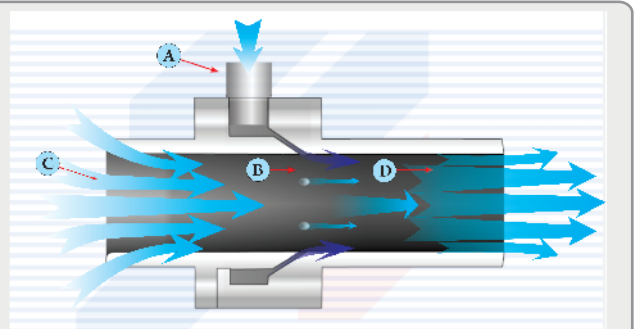

**X-STREAM™ SUPREME PNEUMATIC AIR OPERATED CONVEYOR( XSPC) PERFORMANCE**

Model	Inside Diameter	Outside Diameter	Ai Consumption at 80 PSIG	VACUUM
XSPC25	1” (25 mm)	1.5” (38.1 mm)	46 SCFM (1302 SLPM)	84 inchesH <sub>2</sub> O (21 KPA)
XSPC32	1.25” (32 mm)	1.75” (44 mm)	47 SCFM (1331 SLPM)	61 inchesH <sub>2</sub> O (16 KPA)
XSPC38	1.5” (38 mm)	2” (50 mm)	48 SCFM (1359 SLPM)	34 inchesH <sub>2</sub> O (8.5 KPA)
XSPC50	2.0” (50 mm)	2.5” (64 mm)	50 SCFM (1416 SLPM)	21 inchesH <sub>2</sub> O (5.3 KPA)



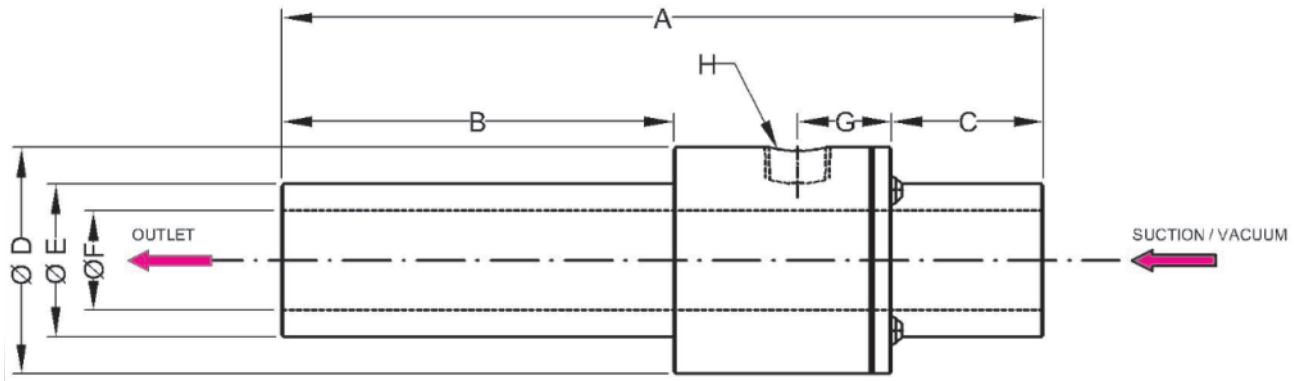

**XSPC DIMENSION TABLE**

PART NUMBER	A IN (MM)	B IN (MM)	C IN (MM)	D IN (MM)	E IN (MM)	F IN (MM)	G IN (MM)	H THREAD
XSPC25	7.5" (196.60)	3.86" (98.10)	1.50" (38.10)	2.22" (56.50)	1.50" (38.10)	0.98" (25.0)	0.93" (23.50)	3/8" NPT
XSPC32	7.5" (196.60)	3.8" (96.60)	1.50" (38.10)	2.50" (63.30)	1.70" (44.00)	1.25" (31.50)	0.93" (23.50)	3/8" NPT
XSPC38	7.5" (196.60)	3.8" (96.60)	1.50" (38.10)	2.80" (69.50)	1.90" (50.00)	1.50" (38.10)	0.93" (23.50)	3/8" NPT
XSPC50	7.2" (182.60)	3.25" (82.50)	1.40" (35.60)	3.54" (90.00)	2.52" (64.00)	1.97" (50.00)	1.14" (29.00)	3/8" NPT

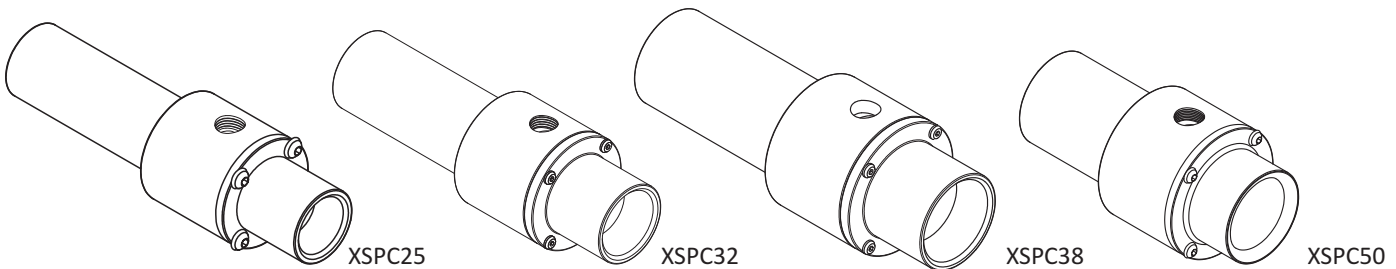
**X-STREAM™ SUPREME PNEUMATIC AIR OPERATED CONVEYORS( XSPC's)**

PART NO.	DESCRIPTION
XSPC25	Powerful, Non-Clogging Pneumatic Conveyor Only
XSPC32	Powerful, Non-Clogging Pneumatic Conveyor Only
XSPC25	Powerful, Non-Clogging Pneumatic Conveyor Only
XSPC32	Powerful, Non-Clogging Pneumatic Conveyor Only
XSPC25 - 1	Powerful, Non-Clogging Pneumatic Conveyor Only plus Filter with Auto Drain
XSPC32 - 1	Powerful, Non-Clogging Pneumatic Conveyor Only plus Filter with Auto Drain
XSPC25 - 1	Powerful, Non-Clogging Pneumatic Conveyor Only plus Filter with Auto Drain
XSPC32 - 1	Powerful, Non-Clogging Pneumatic Conveyor Only plus Filter with Auto Drain
XSPC25 - 2	Powerful, Non-Clogging Pneumatic Conveyor Only + Filter with Auto Drain + Regulator with Gage
XSPC32 - 2	Powerful, Non-Clogging Pneumatic Conveyor Only + Filter with Auto Drain + Regulator with Gage
XSPC25 - 2	Powerful, Non-Clogging Pneumatic Conveyor Only + Filter with Auto Drain + Regulator with Gage
XSPC32 - 2	Powerful, Non-Clogging Pneumatic Conveyor Only + Filter with Auto Drain + Regulator with Gage

**STREAM VAC™**

**Dust Collection and Fume Extraction system for spot applications – portable, low cost, maintenance free**

**WHAT ARE THEY - REASONS TO USE**

The versatile and affordable compact air cleaning system is ideal for the removal of fumes, dust and other air pollution from work stations without the need for heavy and bulky machinery. The **Nex Flow™ Stream Vac™** is an in line air conveyor that when hooked up to a 2" hose and connected to a compressed air line, it will remove up to several hundred cubic feet of air while using only a minimal amount of compressed air, taking with it welding fumes, soldering fumes, particulate from local grinding operations, smoke and particulate from almost any "spot" application.

A safe and improved healthy condition in the workplace improves employee morale, increases worker productivity, decreases absenteeism and even reduces insurance costs in many cases. A cleaner environment can even enhance the performance of machinery and sometimes cut maintenance costs. However, until now there was no low cost solution to enhance the environment.

The low cost, compact and portable, the unit operates utilizing a minimal amount of compressed air. It comes with a magnetic stand to "plug into position" on any magnet accepting metal surface. Simply connect the snap – on collection attachments and clamp a 2" hose on the opposite side, hook up your compressed air and you are set to go.



**STREAM VAC™ FEATURES :**

- ▶ No moving parts.
- ▶ Driven by air not electricity.
- ▶ Compact and portable - easy to install.

**STREAM VAC™ BENEFITS:**

- ▶ Maintenance Free
- ▶ Safe – no electricity
- ▶ Simple to install and use – portable



↑ Stream Vac™ removing soldering fumes from a circuit board soldering station

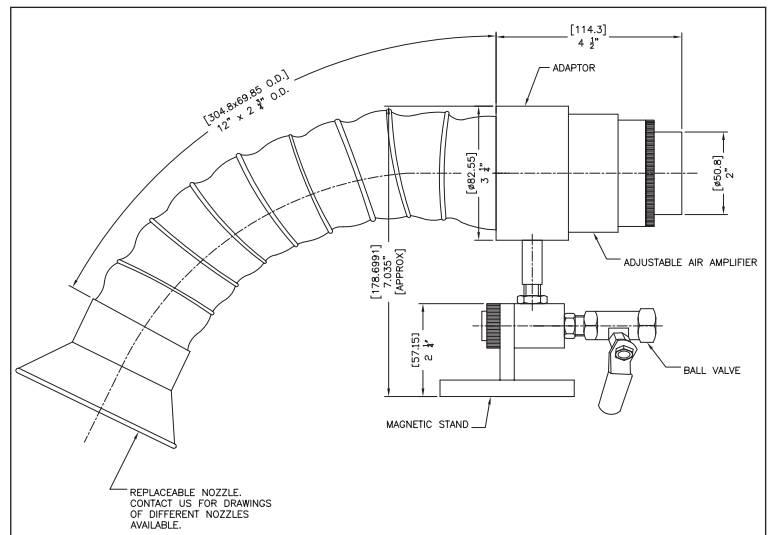

**STREAM VAC™ - HOW IT WORKS:**

The Stream Vac™ is used for the removal of fumes, smoke, dust and particulate at any workbench location with a base that will support the strong magnetic “swivel” base (A) for flexible position of the system. Compressed air is piped in at point (B) on the air amplifier (which is also adjustable to control the suction). Fumes, smoke and particulate enter at (C) and a 2” hose (Customer supplied) at (D) takes the material to a safe location. Three different suction attachments are available. Manual shutoff valve included.

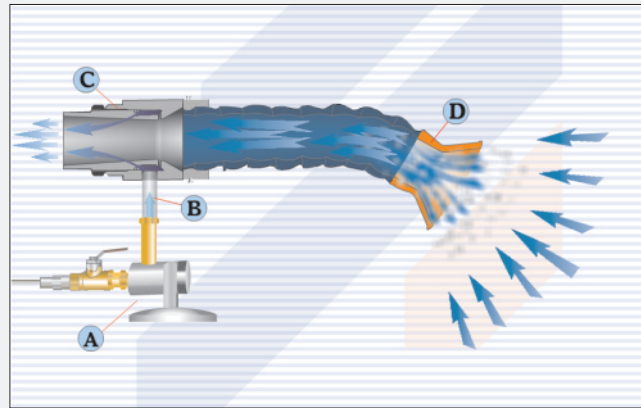

**SPECIFICATIONS:**

The Stream Vac™ uses only 20 SCFM (567 SLPM) at 80 PSIG (5.5 bar) yet will move up to 16 times that volume of air drawing in fumes, dust, smoke and particulate. Standard inlet is 3/8” NPT. Clean, dry air is recommended and an optional filter with automatic drain is available. Three types of suction attachments are supplied in the package which has a strong magnetic base to secure its position.

The Stream Vac™ includes a Model 40002 adjustable air amplifier, magnetic base, manual shutoff valve, all attachments and fittings, and three inlet attachments: round nozzle, rectangular nozzle and tapered oval nozzle.

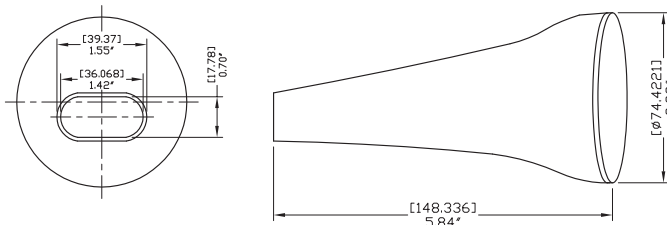

58884 - TAPERED NOZZLE

PART NO.	DESCRIPTION
40002FMS	Stream Vac™ fume removal system c/w magnetic swivel base, assembly, and hose kit
90004	Filter with auto drain
90005	Oil Removal filter with auto drain

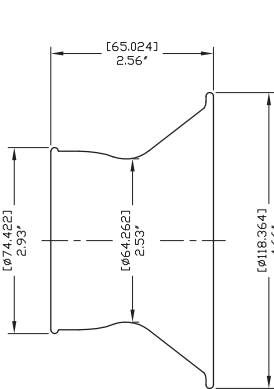

58882 - ROUND NOZZLE

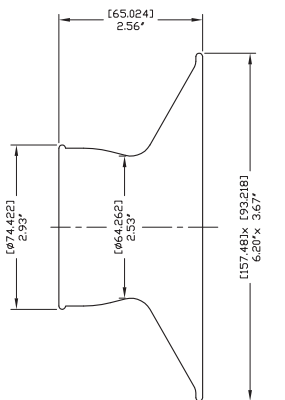

58883 - RECTANGULAR NOZZLE

Stream Vac™ used on manufacturing line to remove welding fumes.



## 316L STAINLESS STEEL REVERSIBLE DRUM ANGEL

Empty or fill a 55-US gallon drum (45 Imperial/205L) in under 90 seconds! Reversible unit fills and empties a drum



### WHAT ARE THEY – REASONS TO USE

The 316L STAINLESS STEEL Reversible Drum Angel/Drum Pump is a maintenance free system to recover spilled liquids, coolant, sludge, tramp oil, waste water and other liquids using only compressed air. The compressed air system attaches easily to any closed head of a drum (30 or 55 US gallon, or 45 Imperial gallon or 205 liter drum). The reversible feature allows you to fill or empty the drum in under two minutes with the simple turn of a knob. The flow rate can be controlled either by a shut-off valve or regulator, or by the knob itself. Drum should have a nominal wall thickness of 1.5mm (16 gauge) and in good condition to maintain integrity of system performance and safety. Using no electricity, these system last and last, unlike many electrical units that wear out quickly in harsh industrial environments. A built in safety feature prevents overflowing and spills



### REVERSIBLE DRUM ANGEL FEATURES:

- ▶ No moving parts
- ▶ Driven by air not electricity
- ▶ 316L Stainless Steel construction
- ▶ Built in pressure relief and vacuum relief systems
- ▶ Compact and portable - easy to install
- ▶ Auto system shutoff to prevent overflow
- ▶ Fits standard closed head drum
- ▶ System is complete with spill recovery system

### REVERSIBLE DRUM ANGEL BENEFITS:

- ▶ Maintenance Free
- ▶ Safe - no electricity and pressure/vacuum relief
- ▶ Long life
- ▶ Simple to install and use - portable
- ▶ Maintenance free with output easily controlled, safe to use
- ▶ Cannot over fill
- ▶ Usable on any standard drum
- ▶ Unlike some competitive unit Drum Angel is complete with a spill recovery skimmer at no extra cost

Reversible Drum Angel is used to remove coolant from a sump. It is then transferred to another location and emptied from the drum.



**REVERSIBLE DRUM ANGEL - HOW IT WORKS**

Reversible Drum Angel/Drum Pump for liquids - Compressed air enters at point (A) and into the Drum Angel/Drum Pump unit (B) which is mounted onto a sealed metal drum via the small hole. An adjustable knob (C) controls whether the unit creates a vacuum inside the drum to fill the drum or pressure to empty the drum. The liquid enters or fills the drum through a tube assembly (D) inserted and threaded into the large drum hole. An elbow attachment (E) connects the tube assembly to the hose and attachment assembly (F) which collects or dispels the liquid. Various attachments are available for liquid collection and transfer.

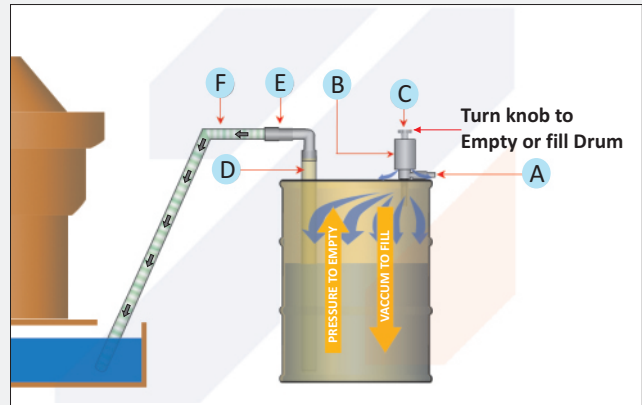

The 316L Stainless Steel Drum Angel Model 35011S includes the Drum Angel unit, crevice tool, skimmer tool and heavy duty squeegee tool, two (2) straight plastic wands, metal wand for use with the heavy duty squeegee tool, 10' of plastic hose with cuffs and drum adaptor with plastic tube. OPTIONAL all 316L stainless drum adaptor and tool available on request at extra cost. Contact representative.

**NOTE:** For safety reasons a steel drum with a nominal thickness of 1.5 mm or 16 gauge is recommended as per ANSI standard # MH2-1997.

**REVERSIBLE DRUM ANGEL**

PART NO.	DESCRIPTION
35011S	Complete Drum Angel Kit for 55-gallon drum
35012S	Complete Drum Angel Kit for 30-gallon drum
35001S	Drum Angel Only

**SPECIFICATIONS:**

The Drum Angel uses only 18 SCFM (510 SLPM) at 80 PSIG (5.5 bar) and can remove water at 30 US gallons per minute (114 Liters per minute). Standard inlet is 1/4" NPT.

The Drum Angel can be used to clean up many kinds of spills quickly and effectively.



**ACCESSORIES**

PART NO.	DESCRIPTION
90001	Filter with auto drain
90012	Manual shutoff valve
90005	Oil Removal filter with auto drain
90041	55-gallon Drum Dolly

**SPECIALTY SMART N CLEVER™ PRODUCTS™**

## X-STREAM™ HAND VAC

Use as a Blow Gun or as A Vacuum to Clean or Transfer Solid Material with no moving parts.

### WHAT ARE THEY - REASONS TO USE

The X-Stream™ hand vac is the low cost solution to a variety of industrial housekeeping applications. It is a blow gun, a vacuum gun, a collection system and a transfer system in one simple package.

The X-Stream™ hand vac is light weight die cast aluminum and uses less air than a normal blow gun. The amplified air flow is approximately 12 times the air consumption. It draws a vacuum at one end to produce a high vacuum for collection or transfer of materials. It is easily converted from a blow gun into a vacuum gun and back again.

In blowoff mode, the 1-1/4" (32 mm) diameter allows it to cover a much greater area than a small blow gun for faster cleaning and drying. It can also be used to transfer material over a long distance using a vacuum hose which can be supplied. In vacuum mode, it can be used to vacuum up debris if more appropriate than blowing air, and debris can be collected in an available reusable vacuum bag.

### X-STREAM™ HAND VAC FEATURES:

- ▶ No moving parts.
- ▶ Driven by air not electricity.
- ▶ Die Cast construction.
- ▶ Can switch from blowoff mode to vacuum in seconds
- ▶ Lightweight and portable
- ▶ No moving parts

### X-STREAM™ HAND VAC BENEFITS:

- ▶ Maintenance Free
- ▶ Safe and Long life
- ▶ Durable
- ▶ Flexible in use - vacuum or blowoff
- ▶ Ergonomic - comfortable to use
- ▶ Maintenance free

### APPLICATIONS:

- ▶ Clean machinery and controls
- ▶ Blowoff coolant, water, chips, scrap
- ▶ Vacuum sawdust and solid spills, shavings, waste
- ▶ Transfer small parts, trim, materials

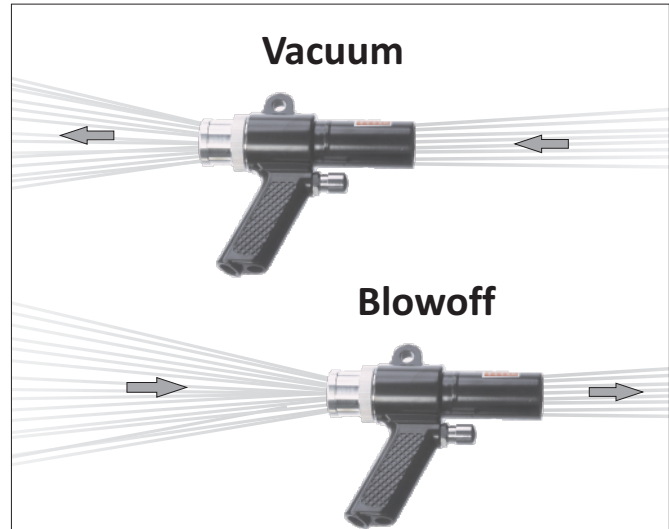

Model 36011 Hand Vac collection system is used to clean & collect dust & dirt from inside a Control Panel.

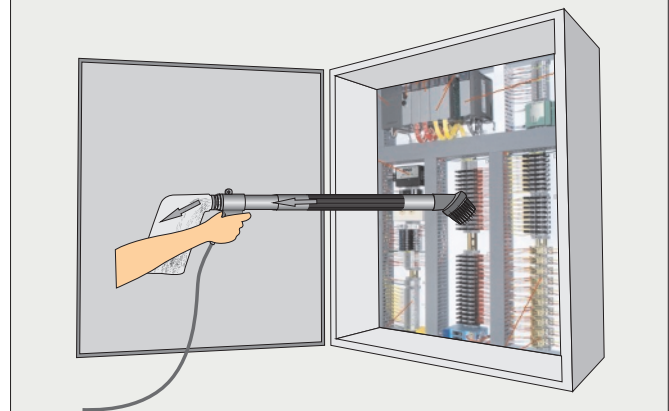

Model 36012 transfer system is used to move ball bearings from a bucket to a storage drum.



**X-STREAM™ HAND VAC - HOW IT WORKS**

X-Stream™ Hand Vac - Compressed air enters at point (A) and is allowed to flow into the Hand Vac using the trigger at point (B). Air either exits at point (C) for blow off or point (C) is a vacuum depending on the setup of the generator inside the Hand Vac. Similarly at point (D), air either enters (in blow off mode) or exits (vacuum mode). The generator inside can be reversed to change mode from blow off to vacuum and back again as required.

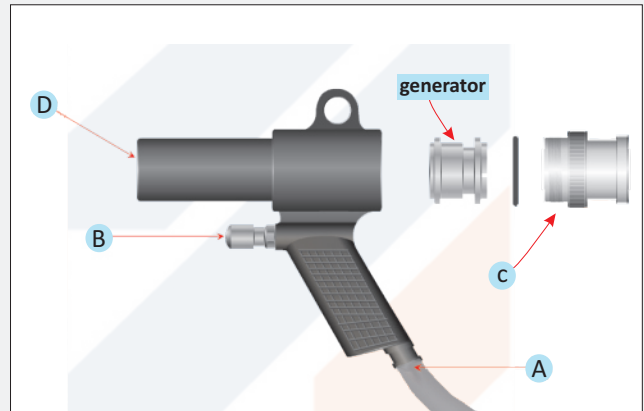

**IN BLOW MODE THE X-STREAM™ HAND VAC CONSUMES LESS AIR THAN ORDINARY BLOW GUNS**

**SPECIFICATIONS:**

The X-Stream™ Hand Vac uses only 13 SCFM (368 SLPM) at 80 PSIG (5.5 Bar) to produce a vacuum of - 29.5 inches water (-7 kPa) and produces a force of 9 ounces (255 grams). Standard inlet is ¼" NPT

**X-STREAM™ HAND VAC**

PART NO.	DESCRIPTION
36011	X-Stream™ Hand-Vac collection system
36012	X-Stream™ Hand-Vac transfer system
36013	X-Stream™ Hand-Vac all purpose system
36001	X-Stream™ Hand-Vac only

**ACCESSORIES**

PART NO.	DESCRIPTION
90001	Filter with auto drain
90005	Oil removal filter with auto drain



Model 36011 - Collection System consists of X-stream™ hand vac plus reusable collection bag, cleaning brush, crevice tool, skimmer tool, two extension wands, and stainless steel hose clamp



Model 36012 – Transfer System consists of X-stream™ hand vac plus 10 foot (3 m) vacuum hose with cuffs at both ends, cleaning brush, crevice tool, skimmer tool, two extension wands, and stainless steel hose clamp



Model 36013 - All Purpose System consists of X-stream™ hand vac plus 10 foot (3 m) vacuum hose with cuffs at both ends, reusable collection bag, cleaning brush, crevice tool, skimmer tool, two extension wands, and stainless steel hose clamp.

**BLOW DIRT, CHIPS, SCRAP OUT OF DEEP BLIND HOLES IN ONE EASY STEP THAT REALLY WORKS!! IDEAL FOR CLEANING DRILLED HOLES AND DEEP CAVITIES. CAN CLEAN HOLES AS BIG AS 1" (25 mm) DIAMETER AND AS DEEP AS 20 inches (525 mm).**

**WHAT ARE THEY - REASONS TO USE**



Unlike make shift vacuum type systems that are cumbersome and do not always work well, the **X-STREAM™ BLIND HOLE CLEANING SYSTEM** actually works and is specifically designed to remove dirt, debris, chips and scrap from drilled holes, deep containers, and grooves -1" diameter to 20" deep!. Only uses 11 SCFM at 80 PSIG for more shallow holes and only 20 SCFM for very deep holes! The **X-STREAM™ BLIND HOLE CLEANING SYSTEM** is ideal for blowing out and collecting chips, contaminants and debris from deep containers, drilled holes and grooves whereas blow guns can create a potentially hazardous situation with flying debris. The **X-STREAM™ BLIND HOLE CLEANING SYSTEM** creates the ideal blow-off force once the hole adaptor is flush with the hole directing the unit in such a way to dislodge and direct all the debris into the collection bag. All dirt and debris are contained within the unit as it is passed into the reusable collection bag, protecting the operator from any contaminants.

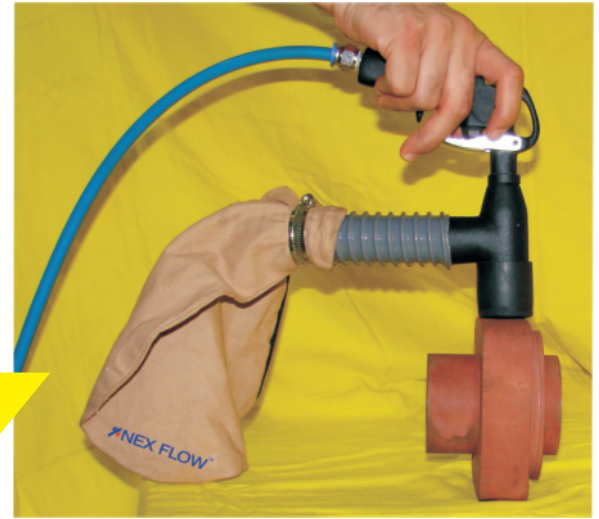

**X-STREAM™ BLIND HOLE CLEANING SYSTEM HOW IT WORKS**

The **X-STREAM™ BLIND HOLE CLEANING SYSTEM** comes complete with hose clamp and material collection bag (F), connected to the Cleaning Gun (B) using a plastic hose connection. Compressed air is supplied into the unit via the customer's air hose (A). The replaceable hole adaptor (E) is connected to the Cleaning Gun. Simply place the hole adaptor (C) over the slot, or hole or container to completely cover the hole. Press the handle on the Cleaning Gun to blow compressed air into the slot, hole or container via the nozzle (D) to remove the debris. Once the bag is filled, remove the bag with the hose clamp, clean and replace

**X-STREAM™ BLIND HOLE CLEANING SYSTEM FEATURES**

- No moving parts
- Driven by air and not electricity
- Aluminum cast construction
- Lightweight and portable
- Various packages available depending on hole diameter & depth
- Custom designs available

**X-STREAM™ BLIND HOLE CLEANING SYSTEM BENEFITS**

- Maintenance Free
- Safe when used as directed
- Long Life
- Durable
- Ergonomic
- No Electricity so no shock hazard
- Low Air consumption

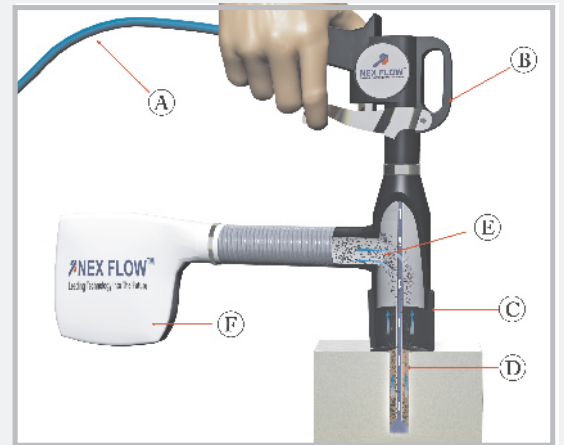



**BLIND HOLE CLEANING SYSTEM** — comes complete with Cleaning Gun, Aluminum cast Hole adaptor, nozzle, collection bag c/w hose clamp and plastic hose connection

PART NO.	DESCRIPTION
48104-16-15	Blind Hole Cleaning System for Max. Hole Dia. of 16 mm and hole depth of 50 mm.
48104-20-15	Blind Hole Cleaning System for Max. Hole Dia. of 20 mm and hole depth of 50 mm.
48104-25-15	Blind Hole Cleaning System for Max. Hole Dia. of 25 mm and hole depth of 50 mm.
48104-16-75	Blind Hole Cleaning System for Max. Hole Dia. of 16 mm and hole depth of 90 mm.
48104-20-75	Blind Hole Cleaning System for Max. Hole Dia. of 20 mm and hole depth of 90 mm.
48104-25-75	Blind Hole Cleaning System for Max. Hole Dia. of 25 mm and hole depth of 90 mm.
48104-16-150	Blind Hole Cleaning System for Max. Hole Dia. of 16 mm and hole depth of 165 mm.
48104-20-150	Blind Hole Cleaning System for Max. Hole Dia. of 20 mm and hole depth of 165 mm.
48104-25-150	Blind Hole Cleaning System for Max. Hole Dia. of 25 mm and hole depth of 165 mm.
48104-16-230	Blind Hole Cleaning System for Max. Hole Dia. of 16 mm and hole depth of 245 mm.
48104-20-230	Blind Hole Cleaning System for Max. Hole Dia. of 20 mm and hole depth of 245mm.
48104-25-230	Blind Hole Cleaning System for Max. Hole Dia. of 25 mm and hole depth of 245 mm.
48104-16-300	Blind Hole Cleaning System for Max. Hole Dia. of 16 mm and hole depth of 315 mm.
48104-20-300	Blind Hole Cleaning System for Max. Hole Dia. of 20 mm and hole depth of 315 mm.
48104-25-300	Blind Hole Cleaning System for Max. Hole Dia. of 25 mm and hole depth of 315 mm.
48104-16-375	Blind Hole Cleaning System for Max. Hole Dia. of 16 mm and hole depth of 390 mm.
48104-20-375	Blind Hole Cleaning System for Max. Hole Dia. of 20 mm and hole depth of 390 mm.
48104-25-375	Blind Hole Cleaning System for Max. Hole Dia. of 25 mm and hole depth of 390 mm.
48104-16-450	Blind Hole Cleaning System for Max. Hole Dia. of 16 mm and hole depth of 465 mm.
48104-20-450	Blind Hole Cleaning System for Max. Hole Dia. of 20 mm and hole depth of 465 mm.
48104-25-450	Blind Hole Cleaning System for Max. Hole Dia. of 25 mm and hole depth of 465 mm.
48104-16-510	Blind Hole Cleaning System for Max. Hole Dia. of 16 mm and hole depth of 525 mm.
48104-20-510	Blind Hole Cleaning System for Max. Hole Dia. of 20 mm and hole depth of 525 mm.
48104-25-510	Blind Hole Cleaning System for Max. Hole Dia. of 25 mm and hole depth of 525 mm.

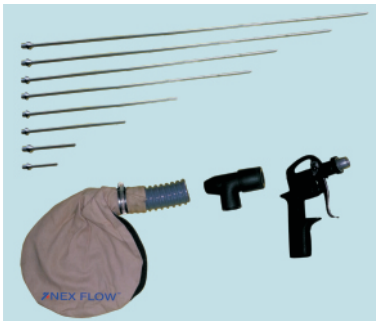

MODEL	DESCRIPTION
48105	Blind Hole Cleaning System Kit with all Hole Adaptors and Nozzles plus Water Removal Filter c/w auto drain

**ACCESSORIES**

MODEL	DESCRIPTION
90004	Water Removal Filter c/w Auto Drain
90005	Oil Removal Filter c/w Auto Drain



**BLIND HOLE CLEANING COMPONENTS**

48102-16	Blind Hole Gun c/w Adaptor for Maximum Hole Diameter of 16 mm – no nozzles
48102-20	Blind Hole Gun c/w Adaptor for Maximum Hole Diameter of 20 mm – no nozzles
48102-25	Blind Hole Gun c/w Adaptor for Maximum Hole Diameter of 25 mm – no nozzles
48100-16	Adaptor Only for Maximum Hole Diameter of 16 mm
48100-20	Adaptor Only for Maximum Hole Diameter of 20 mm
48100-25	Adaptor Only for Maximum Hole Diameter of 25 mm

**NOTE:** All Standard nozzles below are for minimum inside diameter holes of 7 mm. Special small nozzles for smaller holes and other non-standard cavities available on request.

48103-15	Nozzle Length - 15 mm for hole depth up to 50 mm (11 SCFM @80 PSIG)
48103-75	Nozzle Length - 75 mm for hole depth up to 90 mm (20 SCFM @80 PSIG)
48103-150	Nozzle Length - 150 mm for hole depth up to 165 mm (20 SCFM @80 PSIG)
48103-230	Nozzle Length - 230 mm for hole depth up to 245 mm (20 SCFM @80 PSIG)
48103-300	Nozzle Length - 300 mm for hole depth up to 315 mm (20 SCFM @80 PSIG)
48103-375	Nozzle Length - 375 mm for hole depth up to 390 mm (20 SCFM @80 PSIG)
48103-450	Nozzle Length - 450 mm for hole depth up to 465 mm (20 SCFM @80 PSIG)
48103-510	Nozzle Length - 510 mm for hole depth up to 525 mm (20 SCFM @80 PSIG)
48104-0	Bag with plastic hose and Stainless Steel hose clamp

## FRIGID-X™ VORTEX TUBES

Produce cold air as low as minus 50°F (minus 46°C) from compressed air with no moving parts to spot cool or cool enclosures with no electricity

### WHAT ARE THEY - REASONS TO USE

Vortex Tubes are devices that work on a standard compressed air supply. Air enters the vortex tube and is literally split into two parts - cold air at one end, and hot air at the other - all without any moving parts.

Vortex Tubes have an adjustable valve at the "hot" end which controls the volume of the air flow, and the temperature exiting at the cold end. By adjusting the valve, you control the "cold fraction" which is the percentage of total input compressed air that exits the cold end of the Vortex Tube. Our Vortex Tubes may also be supplied with a fixed preset "cold fraction" instead of an adjustable valve.

Inside is the interchangeable brass "generator" which can alter the air used in the Vortex Tube, and control the temperature ranges you wish to have at the cold and hot ends. There are several ranges of generators for compressed air capacity. There are also two basic types of generators - one to produce the extreme cold temperatures (maximum cold temperature out called the C generator) and one type to produce the maximum amount of cooling (maximum refrigeration called the H generator).



### WHY THE FRIGID-X™ VORTEX TUBE OVER OTHERS :

The Frigid-X™ Vortex Tube is constructed of stainless steel and uses a generator and valve made of brass and sealed with viton o-rings to allow their use in the widest range of environments. This also allows for greater life and better consistency between Vortex Tubes made. In addition, it is usable in high temperature environments AS IT COMES with NO extra charge unlike many of our competitors.

Most competitors use plastic generators and standard Buna N O-Rings and charge extra for brass and high temperature-rings. The unique design and quality of materials used in Frigid-X™ products will deliver years of maintenance-free operation.

### FRIGID-X™ VORTEX TUBE ADVANTAGES:

- ▶ No moving parts.
- ▶ Driven by air not electricity.
- ▶ Small and lightweight - portable.
- ▶ Low in cost compared to most others
- ▶ Superior design and performance
- ▶ Maintenance free operation
- ▶ Made of durable stainless steel and metal parts - no cheap plastic parts
- ▶ Adjustable temperature range
- ▶ Generators are interchangeable

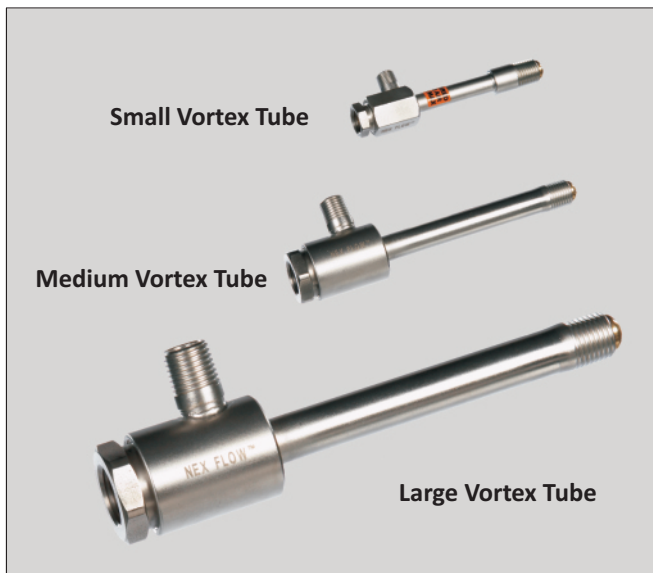

Small Vortex Tube

Medium Vortex Tube

Large Vortex Tube

FRIGID-X™ VORTEX TUBES & SPOT COOLING

**FRIGID-X™ VORTEX TUBE - HOW IT WORKS**

Compressed air enters at point (A). Inside the tube the compressed air is made to spin using a "generator". It travels in one direction along the small (hot end) tube and then back inside itself in the reverse direction creating one stream of air (B) and the second stream of air (C) in the opposite direction. The outside stream of air gets hot and exhausts at point (D). The center column of air gets cold and exists at point (E). Temperatures and capacities can vary by adjusting the hot end plug at (D) and by using different "generators"

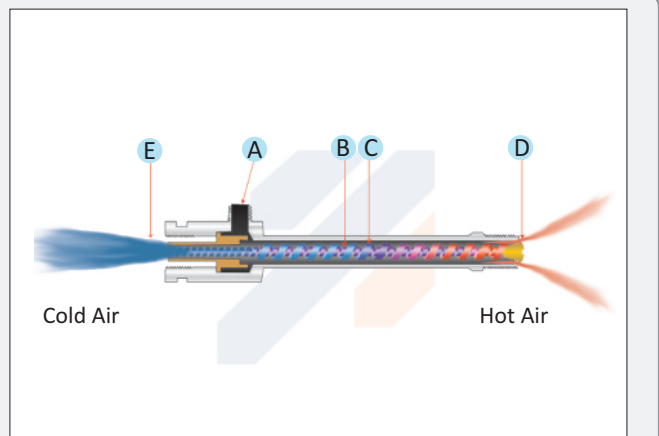

**Due to space limitation & the need to eliminate water cooling the camera, a Model 50025H Vortex Tube was used to cool a camera housing.**

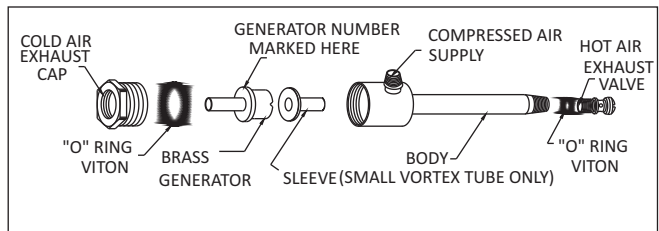
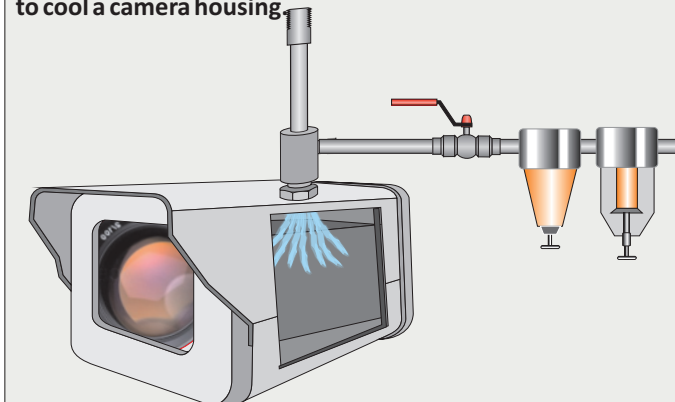

**CONTROLLING THE FLOW RATE AND TEMPERATURE IN THE FRIGID-X™ VORTEX TUBE**

The flow rate and temperature in a Vortex Tube are interdependent. When you open the adjusting valve at the hot end, the cold air flow decreases and the temperature drops. As you close the valve the cold air end flow increases and temperature rises. The percentage of the total input air that exits the cold end is termed the "cold fraction". Depending on inlet air temperature a cold fraction of between 60% and 80% produces the optimum combination of flow and temperature drop for maximum cooling effect, when using an H generator. Lower cold fractions produce colder air but do not cool as well because of reduced flow. Most industrial applications require the 60% to 80% setting and the H generator for optimal cooling.

In some instances such as cooling laboratory samples, testing circuit boards and other "cryogenic" applications, a 'C' generator is used which limits the cold end flow rate to lower levels and produces very cold temperatures.

To set the Vortex Tube to the desired temperature simply insert a thermometer at the cold end and adjust the hot end valve. The optimum cooling effect is achieved when the difference from the inlet air temperature and the cold air drops is 50° F (28° C) if the inlet air is relatively cool to 80° F (45° C) below compressed air temperature if the inlet air is relatively hot.

**Two Vortex Tubes model 50030H with a Model 55002 Muffler cools and Ultrasonic Welding Horn.**

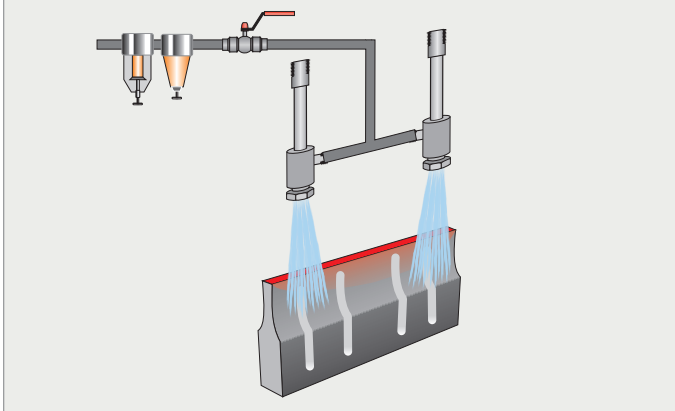

**FRIGID-X™ VORTEX TUBE EXPERIMENTAL KITS**

Three Experimental Kits are available (Small Vortex Tube Kit, Medium Size Vortex Tube Kit and Large Vortex Tube Kit) which contains the appropriate Vortex Tube, all generators for that size, cold end muffler and filter with auto drain to do testing if you are not certain of what exact size you require.



There are three basic physical sizes of Standard Vortex Tubes used in industry - the small, medium and large version. Frigid-X™ Vortex Tubes can be selected by required performance in cooling for the 'H' generator versions and where very cold temperature is required, the 'C' generators are used. However, even with 'C' generators, as expected, the higher the are flow rating the greater any cooling effect.

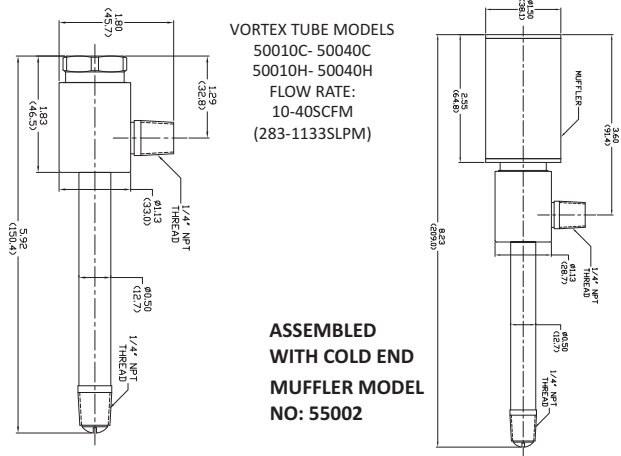

**MEDIUM VORTEX TUBE**

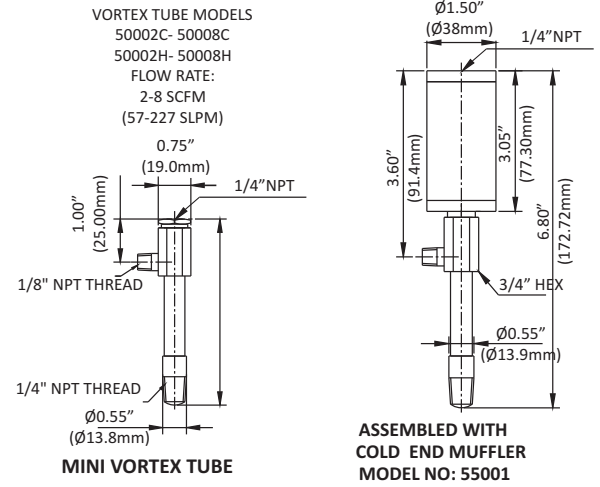

**MINI VORTEX TUBE**

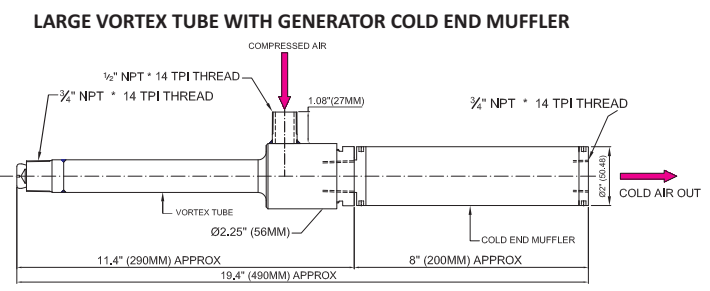
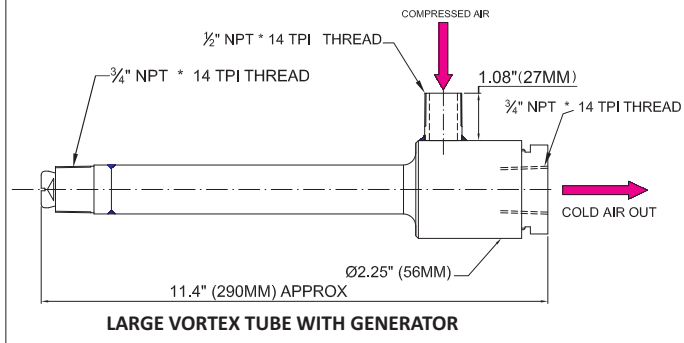

**H series Vortex Tubes (For Maximum Cooling)**

MODEL NO.	SCFM	SLPM	BTU/Hr.	WATTS	SIZE
50002H	2	57	145	42	small
50004H	4	113	290	85	small
50008H	8	227	580	170	small
50010H	10	283	730	214	medium
50015H	15	425	1100	322	medium
50025H	25	708	1800	527	medium
50030H	30	850	2100	615	medium
50040H	40	1133	2900	849	medium
50050H	50	1416	3700	1084	large
50075H	75	2124	5400	1583	large
50100H	100	2832	7100	2081	large
50150H	150	4248	10800	3165	large

**NOTE:**

1. SCFM and SLPM at 100 PSIG or 6.9 bar Inlet Pressure
2. BTU/hr and Watts is Cooling Capacity at 100 PSIG or 6.9 bar inlet pressure and with optimal cold fraction setting

**C series Vortex Tubes (For Maximum Cold Temperature)**

MODEL NO.	SCFM	SLPM	BTU/Hr.	WATTS	SIZE
50002C	2	57	N/A	N/A	small
50004C	4	113	N/A	N/A	small
50008C	8	227	N/A	N/A	small
50010C	10	283	N/A	N/A	medium
50015C	15	425	N/A	N/A	medium
50025C	25	708	N/A	N/A	medium
50030C	30	850	N/A	N/A	medium
50040C	40	1133	N/A	N/A	medium
50050C	50	1416	N/A	N/A	large
50075C	75	2124	N/A	N/A	large
50100C	100	2832	N/A	N/A	large
50150C	150	4248	N/A	N/A	large

**NOTE:**

1. SCFM and SLPM at 100 PSIG or 6.9 bar Inlet Pressure
2. BTU/hr and Watts not applicable as normally not used for air conditioning applications

Approximate temperature drops (and rises) from inlet air temperature produced by a Vortex Tube set at various cold fractions. Assume constant inlet pressure and temperature. Tests were conducted with a 15H generator in a medium size Vortex Tube (Model 50015H). Will vary with other sizes and capacities.

PRESSURE SUPPLY	COLD FRACTION %						
	20	30	40	50	60	70	80
20 (1.4)	62 (34)	60 (33)	56 (31)	51 (28)	44 (24)	36 (20)	28 (16)
	15 (8)	25 (14)	36 (20)	50 (28)	64 (26)	83 (46)	107 (59)
40 (2.8)	88 (48)	85 (46)	80 (42)	73 (39)	63 (34)	52 (28)	38 (20)
	21 (11)	35 (18)	52 (28)	71 (38)	92 (50)	117 (62)	147 (80)
60 (4.1)	104 (57)	100 (55)	93 (51)	84 (46)	73 (40)	60 (33)	46 (25)
	24 (14)	40 (22)	59 (33)	80 (44)	104 (57)	132 (73)	166 (92)
80 (5.5)	115 (63)	110 (62)	102 (56)	92 (51)	80 (45)	66 (36)	50 (28)
	25 (14)	43 (24)	63 (35)	86 (47)	113 (63)	143 (80)	180 (100)
100 (6.9)	123 (68)	118 (65)	110 (61)	100 (55)	86 (48)	71 (39)	54 (30)
	26 (14)	45 (25)	67 (37)	90 (50)	119 (66)	151 (84)	191 (106)
120 (8.4)	129 (72)	124 (69)	116 (64)	104 (58)	91 (50)	74 (41)	55 (31)
	26 (14)	46 (26)	69 (38)	94 (52)	123 (68)	156 (86)	195 (108)

Temperature drop of cold air, °F (°C) in blue

Temperature rise of hot air, °F (°C) in red

**USING THE VORTEX TUBE :**

Back pressures over 2 psig (0.1 bar) can reduce the performance of a Vortex Tube. Similarly it is important to use a minimum of 25 micron or less filtration to keep the air clean and dry. Vortex tubes alone without ducting can be noisy so mufflers are available for both the cold end and hot end. All of our Vortex Tubes are built to be used in even high temperature environments at no extra cost.

**VORTEX TUBE THEORIES :**

There are many theories of the Vortex Tube also known as the Ranque Vortex Tube, the Hilsch Tube, Maxwell’s Demon Tube, and the Ranque - Hilsch Tube. Invented in 1933 by French physicist Georges J. Ranque and improved upon by German physicist Rudolf Hilsch in a notable paper published in 1947, there is a great deal of information available on the internet.

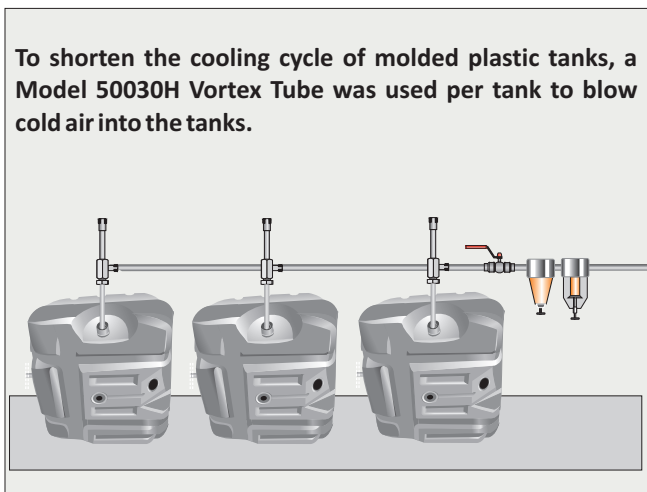

**FRIGID-X™ VORTEX TUBES**

Part No.	Description
50002H	Small Vortex Tube with 2H Generator for Maximum cooling Effect
50004H	Small Vortex Tube with 4H Generator for Maximum cooling Effect
50008H	Small Vortex Tube with 8H Generator for Maximum cooling Effect
50010H	Medium Vortex Tube with 10H Generator for Maximum cooling Effect
50015H	Medium Vortex Tube with 15H Generator for Maximum cooling Effect
50025H	Medium Vortex Tube with 25H Generator for Maximum cooling Effect
50030H	Medium Vortex Tube with 30H Generator for Maximum cooling Effect
50040H	Medium Vortex Tube with 40H Generator for Maximum cooling Effect
50050H	Large Vortex Tube with 50H Generator for Maximum cooling Effect
50075H	Large Vortex Tube with 75H Generator for Maximum cooling Effect
50100H	Large Vortex Tube with 100H Generator for Maximum cooling Effect
50150H	Large Vortex Tube with 150H Generator for Maximum cooling Effect
50002C	Small Vortex Tube with 2C Generator for Maximum Cold Temperature
50004C	Small Vortex Tube with 4C Generator for Maximum Cold Temperature
50008C	Small Vortex Tube with 8C Generator for Maximum Cold Temperature
50010C	Medium Vortex Tube with 10C Generator for Maximum Cold Temperature
50015C	Medium Vortex Tube with 15C Generator for Maximum Cold Temperature
50025C	Medium Vortex Tube with 25C Generator for Maximum Cold Temperature
50030C	Medium Vortex Tube with 30C Generator for Maximum Cold Temperature
50040C	Medium Vortex Tube with 40C Generator for Maximum Cold Temperature
50050C	Large Vortex Tube with 50C Generator for Maximum Cold Temperature
50075C	Large Vortex Tube with 75C Generator for Maximum Cold Temperature
50100C	Large Vortex Tube with 100C Generator for Maximum Cold Temperature
50150C	Large Vortex Tube with 150C Generator for Maximum Cold Temperature
55001	Cold End Muffler for Small Vortex Tube
55002	Cold End Muffler for Medium Vortex Tube
55003	Hot End Muffler for Small or Medium Vortex Tube
55004	X-Stream Hot End Muffler for Small & Medium Vortex Tubes for extra Muffling
55006	Cold End Muffler for Large Vortex Tube
55007	Hot End Muffler for Large Vortex Tube
51008K	Small Vortex Tube test Kit. Consists of Small Vortex Tube, Cold Muffler, Filter with auto drain, and Generators - 2C, 2H, 4C, 4H, 8C, 8H
51040K	Medium Vortex Tube test Kit. Consists of Medium Vortex Tube, Cold Muffler, Filter with auto drain, and Generators - 10C, 10H, 15C, 15H, 25C, 25H, 30C, 30H, 40C, 40H
51150K	Large Vortex Tube test Kit. Consists of Large Vortex Tube, Cold Muffler, Filter with auto drain, and Generators - 50C, 50H, 75C, 75H, 100C, 100H, 150C, 150H
59008K	Small Vortex Tube Generator Kit Generators - 2C, 2H, 4C, 4H, 8C, 8H
59040K	Medium Vortex Tube Generator Kit Generators - 10C, 10H, 15C, 15H, 25C, 25H, 30C, 30H, 40C, 40H
59150K	Large Vortex Tube Generator Kit Generators - 50C, 50H, 75C, 75H, 100C, 100H, 150C, 150H

**NOTE:** The last three numbers in the part number indicate the SCFM consumption at 100 PSIG (6.9 Bar) - Example 50025C indicates 25 SCFM air consumption at 100 PSIG (6.9 Bar).

The PLCFC described in Section A is an effective means to control energy used by turning on and off the Vortex Tubes as required.



**FRIGID-X™ VORTEX TUBES & SPOT COOLING**

**FRIGID-X™ VORTEX TUBES**

Part No.	Description
59002C	2 SCFM Small Vortex Tube Brass Generator Only - Cold Temp.
59004C	4 SCFM Small Vortex Tube Brass Generator Only - Cold Temp.
59008C	8 SCFM Small Vortex Tube Brass Generator Only - Cold Temp.
59002H	2 SCFM Small Vortex Tube Brass Generator Only - Max. BTU/hr
59004H	4 SCFM Small Vortex Tube Brass Generator Only - Max. BTU/hr
59008H	8 SCFM Small Vortex Tube Brass Generator Only - Max. BTU/hr
59010C	10 SCFM Medium Vortex Tube Brass Generator Only - Cold Temp.
59015C	15 SCFM Medium Vortex Tube Brass Generator Only - Cold Temp.
59025C	25 SCFM Medium Vortex Tube Brass Generator Only - Cold Temp.
59030C	30 SCFM Medium Vortex Tube Brass Generator Only - Cold Temp.
59040C	40 SCFM Medium Vortex Tube Brass Generator Only - Cold Temp.
59010H	10 SCFM Medium Vortex Tube Brass Generator Only - Max. BTU/Hr.
59015H	15 SCFM Medium Vortex Tube Brass Generator Only - Max. BTU/Hr.
59025H	25 SCFM Medium Vortex Tube Brass Generator Only - Max. BTU/Hr.
59030H	30 SCFM Medium Vortex Tube Brass Generator Only - Max. BTU/Hr.
59040H	40 SCFM Medium Vortex Tube Brass Generator Only - Max. BTU/Hr.
59050C	50 SCFM Large Vortex Tube Brass Generator Only - Cold Temp.
59075C	75 SCFM Large Vortex Tube Brass Generator Only - Cold Temp.
59100C	100 SCFM Large Vortex Tube Brass Generator Only - Cold Temp.
59150C	150 SCFM Large Vortex Tube Brass Generator Only - Cold Temp.
59050H	50 SCFM Large Vortex Tube Brass Generator Only - Max. BTU/Hr.
59075H	75 SCFM Large Vortex Tube Brass Generator Only - Max. BTU/Hr.
59100H	100 SCFM Large Vortex Tube Brass Generator Only - Max. BTU/Hr.
59150H	150 SCFM Large Vortex Tube Brass Generator Only - Max. BTU/Hr.

Accessories	
90001	3/8" NPT Filter with automatic drain - 65 SCFM (1841 SLPM) capacity
90002	3/4" NPT Filter with automatic drain - 200 SCFM (6230 SLPM) capacity
90005	3/8" NPT Oil Removal Filter with automatic drain - 15 - 37 SCFM (425 - 1048 SLPM) capacity
90006	3/4" NPT Oil Removal Filter with automatic drain - 50 - 150 SCFM (1415 - 4248 SLPM) capacity



## FRIGID-X™ VORTEX TUBES With Hand Adjustable and Muffled Hot End

Produce cold air as low as minus 50° F (minus 46° C) from compressed air with no moving parts to spot cool or cool enclosures with no electricity and easily adjust the setting by hand to control the temperature and flow rates.

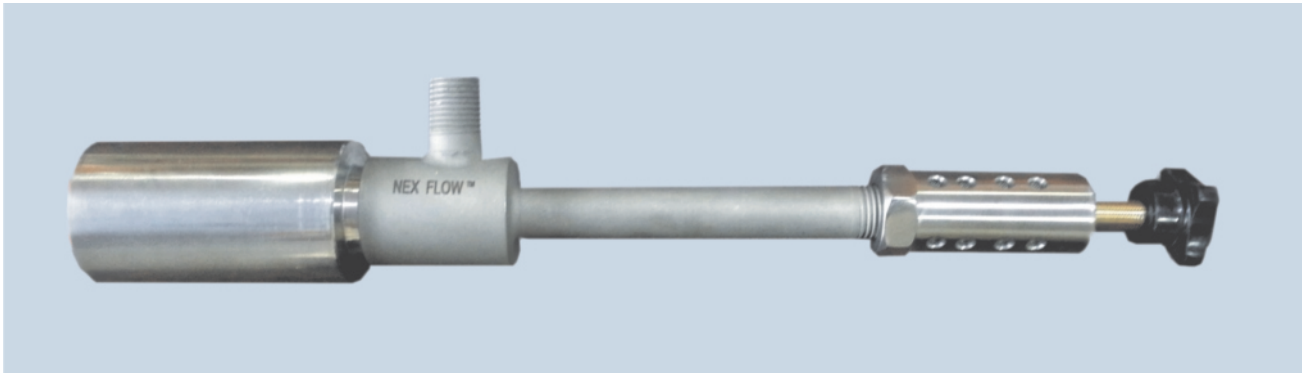

### WHAT ARE THEY - REASONS TO USE

Nex Flow™ Frigid-X™ Vortex Tubes normally come with an adjustable hot end that requires a screwdriver to change the setting. If the application requires an easier adjusting mechanism the Hand Adjustable version is available. For the small and medium sized vortex tubes. It comes with a built in hot end muffler for noise reduction and is made of stainless steel. The Hand Adjustable assembly may also be purchased separately to convert the standard Vortex Tube into a hand adjustable version.

Inside the vortex tube is the interchangeable brass generator which determines the air flow capacity. There are two types – one to produce extreme cold temperatures (maximum cold temperature out call the C generator) and one type to produce the maximum amount of cooling (maximum refrigeration called the H generator). The Hand Adjustable units are used only with the H generators.

### WHY THE FRIGID-X™ HAND ADJUSTABLE UNIT:

The Nex Flow™ Frigid-X™ Vortex Tube is constructed of stainless steel and uses a brass generator and brass and stainless hand adjustable system with a plastic knob and integral muffler to allow it to be used in the widest range of environments. In applications which adjustment convenience is necessary this system is an ideal solution. The unique design and quality of materials used in the Frigid-X™ Vortex Tubes will deliver years of maintenance-free operation.

### FRIGID-X™ HAND ADJUSTABLE UNIT ADVANTAGES:

- easy adjustment – no screwdriver needed
- driven by air no electricity
- Small and lightweight – portable
- Low in cost compared to others
- Maintenance free operation
- Adjustable temperature range





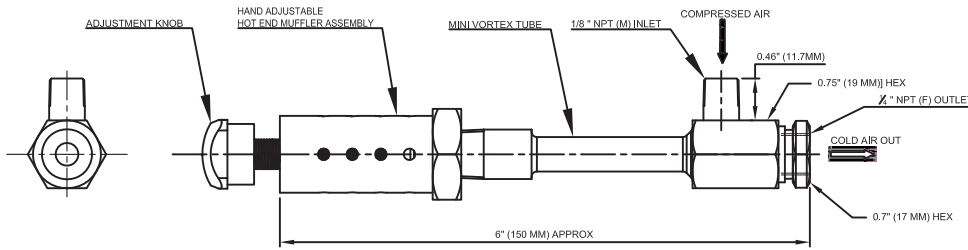

**SMALL VORTEX TUBE WITH GENERATOR, HAND ADJUSTABLE HOT END MUFFLER ASSEMBLY**

**SMALL VORTEX TUBE WITH GENERATOR, HAND ADJUSTABLE HOT END MUFFLER ASSEMBLY + COLD MUFFLER**

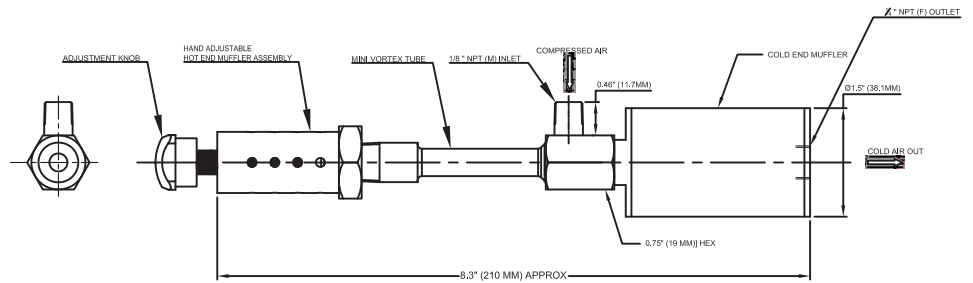

**SMALL VORTEX TUBE WITH GENERATOR, HAND ADJUSTABLE HOT END MUFFLER ASSEMBLY + COLD MUFFLER + SINGLE POINT HOSE KIT**

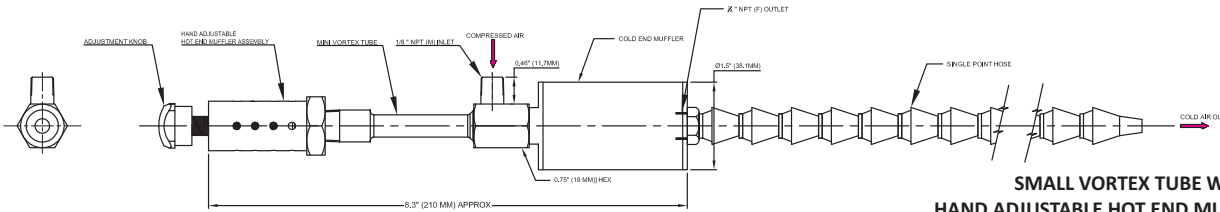

**SMALL VORTEX TUBE WITH GENERATOR, HAND ADJUSTABLE HOT END MUFFLER ASSEMBLY + SINGLE POINT HOSE KIT**

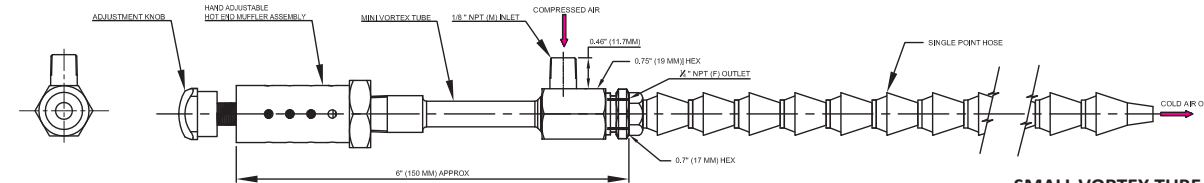

**MEDIUM VORTEX TUBE WITH GENERATOR, HAND ADJUSTABLE HOT END MUFFLER ASSEMBLY**

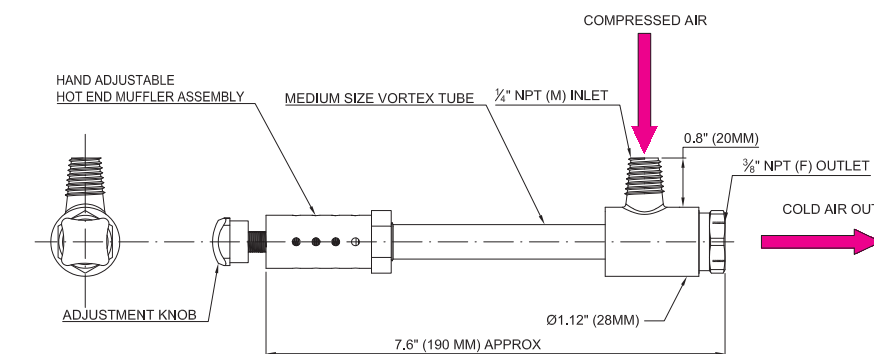

**MEDIUM VORTEX TUBE WITH GENERATOR, HAND ADJUSTABLE HOT END MUFFLER ASSEMBLY + COLD MUFFLER**

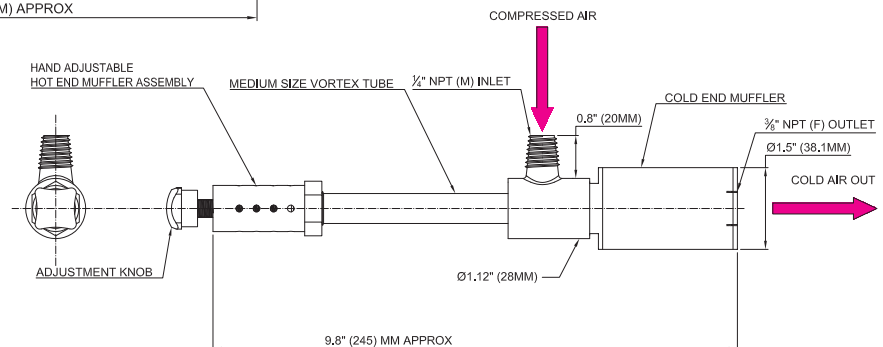

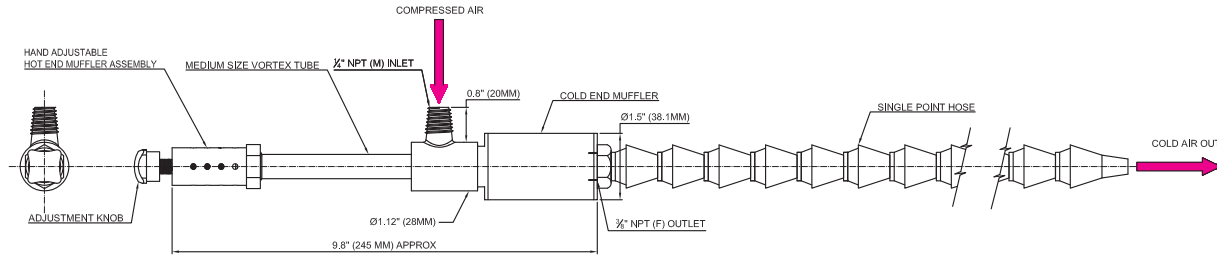

**MEDIUM VORTEX TUBE WITH GENERATOR, HAND ADJUSTABLE HOT END MUFFLER ASSEMBLY + COLD MUFFLER + SINGLE POINT HOSE KIT**

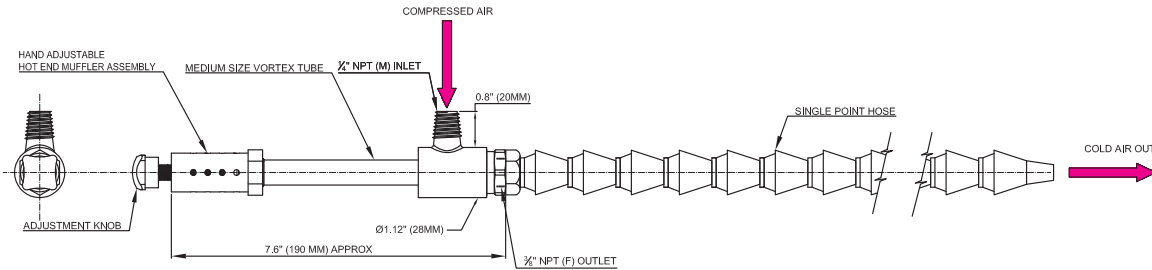

**MEDIUM VORTEX TUBE WITH GENERATOR, HAND ADJUSTABLE HOT END MUFFLER ASSEMBLY + SINGLE POINT HOSE KIT**

**SPECIFICATIONS**

<b>52002H - 2 SCFM (57 SLPM) – for Maximum Cooling 145 BTU/hr. (42 watts) – small vortex tube</b>
<b>52004H - 4 SCFM (113 SLPM) – for Maximum Cooling 290 BTU/hr. (85 watts) – small vortex tube</b>
<b>52008H - 8 SCFM (227 SLPM) – for Maximum Cooling 580 BTU/hr. (170 watts) – small vortex tube</b>
<b>52010H - 10 SCFM (283 SLPM) – for Maximum Cooling 730 BTU/hr. (214 watts) – small vortex tube</b>
<b>52015H - 15 SCFM (425 SLPM) – for Maximum Cooling 1100 BTU/hr. (322 watts) – small vortex tube</b>
<b>52025H - 25 SCFM (708 SLPM) – for Maximum Cooling 1800 BTU/hr. (527 watts) – small vortex tube</b>
<b>52030H - 30 SCFM (850 SLPM) – for Maximum Cooling 2100 BTU/hr. (615 watts) – small vortex tube</b>
<b>52040H - 40 SCFM (1133 SLPM) – for Maximum Cooling 2900 BTU/hr. (849 watts) – small vortex tube</b>

Part No.	Description
52002H	Small Vortex Tube with Generator, hand adjustable hot end muffler assembly
52004H	Small Vortex Tube with Generator, hand adjustable hot end muffler assembly
52008H	Small Vortex Tube with Generator, hand adjustable hot end muffler assembly
52010H	Medium Vortex Tube with Generator, hand adjustable hot end muffler assembly
52015H	Medium Vortex Tube with Generator, hand adjustable hot end muffler assembly
52025H	Medium Vortex Tube with Generator, hand adjustable hot end muffler assembly
52030H	Medium Vortex Tube with Generator, hand adjustable hot end muffler assembly
52040H	Medium Vortex Tube with Generator, hand adjustable hot end muffler assembly
53002H	Small Vortex Tube with Generator, hand adjustable hot end muffler assembly + cold muffler
53004H	Small Vortex Tube with Generator, hand adjustable hot end muffler assembly + cold muffler
53008H	Small Vortex Tube with Generator, hand adjustable hot end muffler assembly + cold muffler

FRIGID-X™ VORTEX TUBES & SPOT COOLING

Part No.	Description
53010H	Medium Vortex Tube with Generator, hand adjustable hot end muffler assembly + cold muffler
53015H	Medium Vortex Tube with Generator, hand adjustable hot end muffler assembly + cold muffler
53025H	Medium Vortex Tube with Generator, hand adjustable hot end muffler assembly + cold muffler
53030H	Medium Vortex Tube with Generator, hand adjustable hot end muffler assembly + cold muffler
53040H	Medium Vortex Tube with Generator, hand adjustable hot end muffler assembly + cold muffler
53002HS	Small Vortex Tube with Generator, hand adjustable hot end muffler assembly + cold muffler + single point hose kit
53004HS	Small Vortex Tube with Generator, hand adjustable hot end muffler assembly + cold muffler + single point hose kit
53008HS	Small Vortex Tube with Generator, hand adjustable hot end muffler assembly + cold muffler + single point hose kit
53010HS	Medium Vortex Tube with Generator, hand adjustable hot end muffler assembly + cold muffler + single point hose kit
53015HS	Medium Vortex Tube with Generator, hand adjustable hot end muffler assembly + cold muffler + single point hose kit
53025HS	Medium Vortex Tube with Generator, hand adjustable hot end muffler assembly + cold muffler + single point hose kit
53030HS	Medium Vortex Tube with Generator, hand adjustable hot end muffler assembly + cold muffler + single point hose kit
53040HS	Medium Vortex Tube with Generator, hand adjustable hot end muffler assembly + cold muffler + single point hose kit
53010HD	Medium Vortex Tube with Generator, hand adjustable hot end muffler assembly + cold muffler + dual point hose kit
53015HD	Medium Vortex Tube with Generator, hand adjustable hot end muffler assembly + cold muffler + dual point hose kit
53025HD	Medium Vortex Tube with Generator, hand adjustable hot end muffler assembly + cold muffler + dual point hose kit
53030HD	Medium Vortex Tube with Generator, hand adjustable hot end muffler assembly + cold muffler + dual point hose kit
53040HD	Medium Vortex Tube with Generator, hand adjustable hot end muffler assembly + cold muffler + dual point hose kit
52002HS	Small Vortex Tube with Generator, hand adjustable hot end muffler assembly + single point hose kit
52004HS	Small Vortex Tube with Generator, hand adjustable hot end muffler assembly + single point hose kit
52008HS	Small Vortex Tube with Generator, hand adjustable hot end muffler assembly + single point hose kit
52010HS	Medium Vortex Tube with Generator, hand adjustable hot end muffler assembly + single point hose kit
52015HS	Medium Vortex Tube with Generator, hand adjustable hot end muffler assembly + single point hose kit
52025HS	Medium Vortex Tube with Generator, hand adjustable hot end muffler assembly + single point hose kit
52030HS	Medium Vortex Tube with Generator, hand adjustable hot end muffler assembly + single point hose kit
52040HS	Medium Vortex Tube with Generator, hand adjustable hot end muffler assembly + single point hose kit
52010HD	Medium Vortex Tube with Generator, hand adjustable hot end muffler assembly + dual point hose kit
52015HD	Medium Vortex Tube with Generator, hand adjustable hot end muffler assembly + dual point hose kit
52025HD	Medium Vortex Tube with Generator, hand adjustable hot end muffler assembly + dual point hose kit
52030HD	Medium Vortex Tube with Generator, hand adjustable hot end muffler assembly + dual point hose kit
52040HD	Medium Vortex Tube with Generator, hand adjustable hot end muffler assembly + dual point hose kit
55008	Hand turning adjustable hot end only c/w muffler for medium and small vortex tube

## FRIGID-X™ ADJUSTABLE SPOT COOLER

Produce cold air as low as minus 30° F (minus 34° C) from compressed air to spot cool with easy adjustability

### WHAT ARE THEY - REASONS TO USE

The Frigid-X™ Adjustable Spot Cooler is a low cost and maintenance free system which utilizes a vortex tube to produce cold air at one end.

The Frigid-X™ Adjustable Spot Cooler temperature can be adjusted using a knob at the hot end to set the temperature precisely to your requirements. Temperatures range from approximately minus 30°F to room temperature and can be easily set with a thermometer.

The Frigid-X™ Adjustable Spot Cooler System comes with three brass generators for flow rate adjustment - 15 SCFM (425 SLPM), 25 SCFM (708 SLPM) and 30 SCFM (850 SLPM) providing refrigeration up to 2100 BTU/hr (615 Watts).

Cold air is directed using the flexible tubing. A magnetic base is standard for portability and easy mounting of the adjustable spot cooler.

Units are available with either a single point hose kit for small surface area or a dual point hose kit when heat is generated over a larger surface area. Adjustable spot cooler produces a wide range of airflow and temperature by adjusting the knob at the hot end and changing the various generators supplied.

The generators control the air consumption and are easily interchangeable. Adjustable spot cooler has a 25 SCFM (708 SLPM) generator installed that will produce up to 1,800 Btu/hr. of cooling. If less is required, the 15 SCFM (425 SLPM) generator can deliver 1,100 BTU/Hr. If more cooling is needed Nex Flow™ can supply you with the 30 SCFM (850 SLPM) generator for up to 2,100 BTU/Hr. of cooling.

### WHY THE FRIGID-X™ ADJUSTABLE SPOT COOLER OVER OTHERS:

All Metal Parts, Stainless Steel Body, Quiet - Tests Show Frigid-X™ Adjustable Spot Cooler is consistently more quiet than the competition.



### FRIGID-X™ ADJUSTABLE SPOT COOLER ADVANTAGES:

- ▶ No moving parts.
- ▶ Quiet
- ▶ Driven by air not electricity.
- ▶ Small and lightweight - portable.
- ▶ Low in cost compared to most others
- ▶ Superior design and performance
- ▶ Maintenance free operation
- ▶ Made of durable stainless steel and metal parts, no cheap plastic parts
- ▶ Adjustable temperature range
- ▶ Generators are interchangeable
- ▶ System uses strong magnetic base

A Model 57025AS is used to cool a milling operation of a special ceramic material where the temperature had to be tightly controlled.

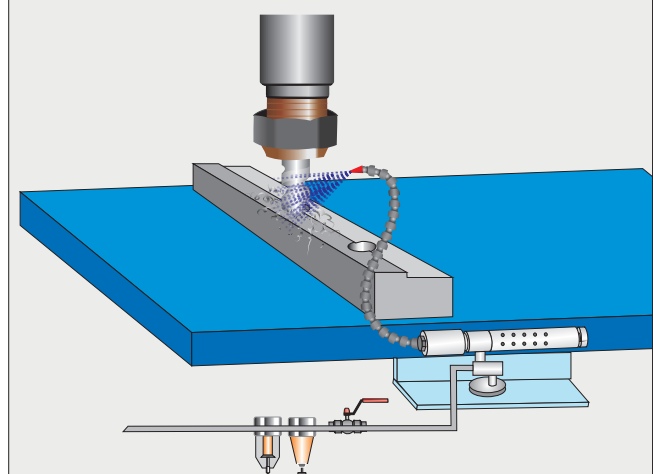

**FRIGID-X™ ADJUSTABLE SPOT COOLER – HOW IT WORKS**

Frigid-X™ - Adjustable Spot Cooler - Compressed air enters at point (A) into the vortex tube component of the spot cooler. The vortex tube splits the compressed air into a hot (B) and cold (C) stream of air. The hot air from the vortex tube is vented to the atmosphere at point (D) after being muffled to reduce noise. Cold air enters into the muffler (E) and then distributed through the hose distribution kit (F) and onto the item being cooled. A strong magnet (G) holds the spot cooler in place. The temperature of the cold air is controlled by an adjustable knob.

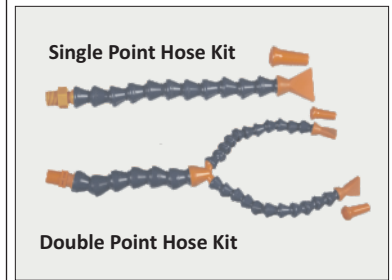
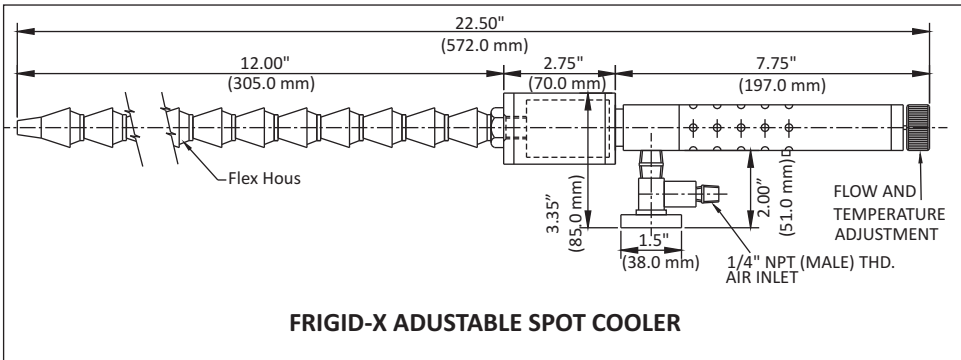
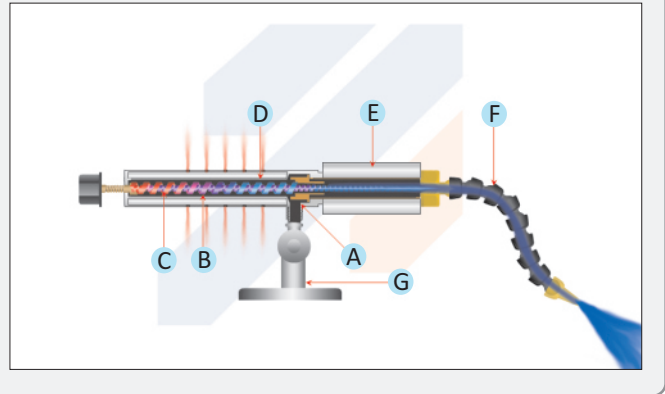

**FRIGID-X™ ADJUSTABLE SPOT COOLER APPLICATIONS:**

- ▶ Solder Cooling
- ▶ Adjusting thermostats
- ▶ Cool plastic machined parts
- ▶ Set hot melt adhesives
- ▶ Cool welding horns on ultrasonic
- ▶ Cool molded plastics
- ▶ Cool Electronic components
- ▶ Cool heat shrink tubing

INLET PRESSURE PSIG (Bar)	AIR CONSUMPTION SCFM (SLPM)	SOUND LEVEL dBA
100 (6.9)	15 (425)	70
100 (6.9)	25 (708)	71
100 (6.9)	30 (850)	72

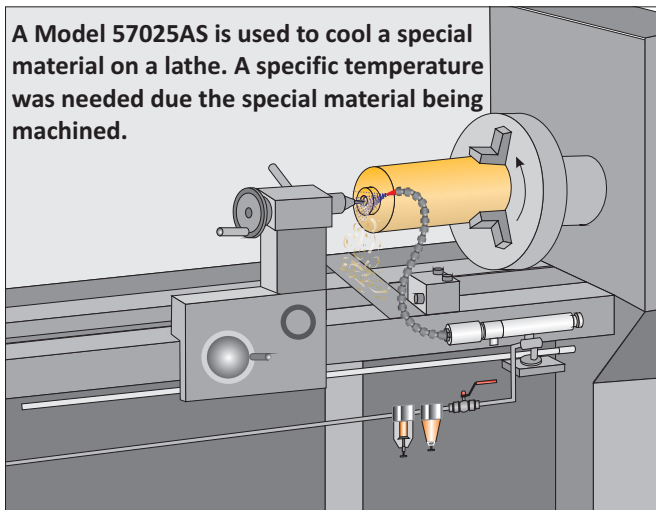

**FRIGID-X™ ADJUSTABLE SPOT COOLER**

PART NO.	DESCRIPTION
57025AS	Frigid-X™ Adjustable Spot Cooler System c/w cooler, magnetic base, single point hose kit, 25H generator (Installed), 15H generator (loose), 30H generator (loose)
57025AD	Frigid-X™ Adjustable Spot Cooler System c/w cooler, magnetic base, dual point hose kit, 25H generator (installed), 15H generator (loose), 30H generator (loose)
56025A	FRIGID-X™ Adjustable Spot Cooler only
OPTIONS	
90001	Filter with automatic drain, 3/8" NPT, 65 SCFM (1841 SLPM)
90005	Oil Removal Filter, 3/8" NPT, 15-37 SCFM (425 to 1048 SLPM)

## FRIGID-X™ MINI SPOT COOLER

Cool small parts and tooling with a compact spot cooler with no moving parts.

### WHAT ARE THEY - REASONS TO USE

The Frigid-X™ Mini Spot Cooler is a low cost and maintenance free system which utilizes a vortex tube to produce cold air at one end. It is quiet and compact.

Designed for small parts, the Frigid-X™ Mini Spot Cooler produces a stream of 15 to 20 degree F (minus 9.5 to 7 degree C) of cold air to prevent heat buildup depending in inlet air temperature. It can improve tolerances in machining of small critical parts and increase production rates.

Cold air is directed using the flexible tubing. A magnetic base is standard for portability and easy mounting of the mini spot cooler

### APPLICATIONS:

- ▶ Needle cooling on sewing machines
- ▶ Cooling small blades
- ▶ Grinding lenses and small parts
- ▶ Cooling small tools

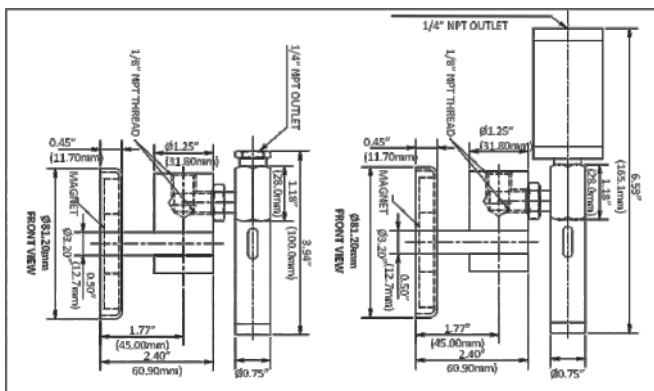

### FRIGID-X™ MINI SPOT COOLER

PART NO.	DESCRIPTION
56008F	Mini Frigid-X™ Cooler only (no muffler)
56108F	Mini Frigid-X™ Cooler only (with muffler)
57008F	Frigid-X™ Mini Spot Cooler System c/w cooler, magnetic base, single point hose kit
56008F	Frigid-X™ Mini Spot Cooler only options
90003	Filter with Manual Drain ¼ " NPT

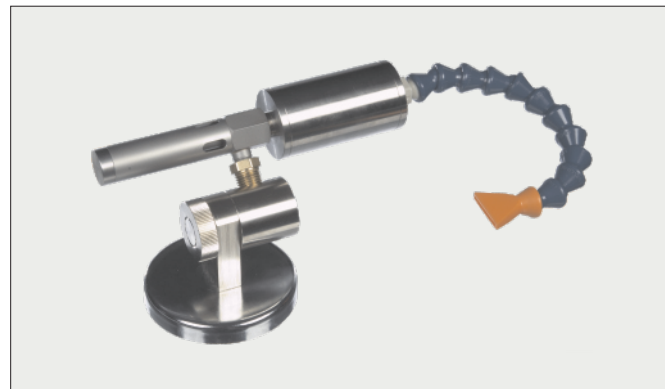

The Mini Spot Cooler utilizes a vortex tube to create one hot stream and one cold stream (see page 9). The cold air produced at the cold end is directed to the surface to be cooled using a flexible hose.

The Mini Spot Cooler is used in the cooling of needles on a sewing machine used to produce heavy materials for carpeting.

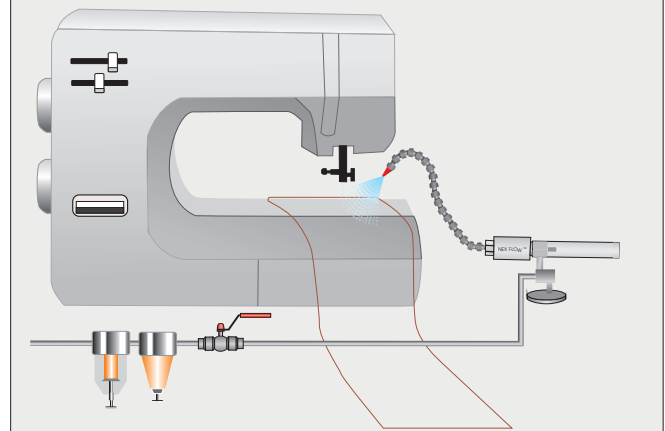

**FRIGID-X™ BOX COOLER**

Packaged System for cooling small enclosures



**WHAT ARE THEY - REASONS TO USE**

The Frigid-X™ Box Cooler is used for cooling small enclosures for laboratory use, environmental chambers and any application where an enclosure needs cooling (Note: Not approved for electrical and electronic control panels but may be used if approvals not required). This low cost system utilizes a stainless steel vortex tube with an adjustable hot end to control the temperature produced in the enclosure. In the package are all the necessary items to attach the vortex tube along with a separate venting unit to exhaust the hot air being displaced inside the enclosure. An optional hose distribution kit is available to distribute the cold air inside for larger enclosures. Also available is an optional solenoid and thermostat for on-off control.

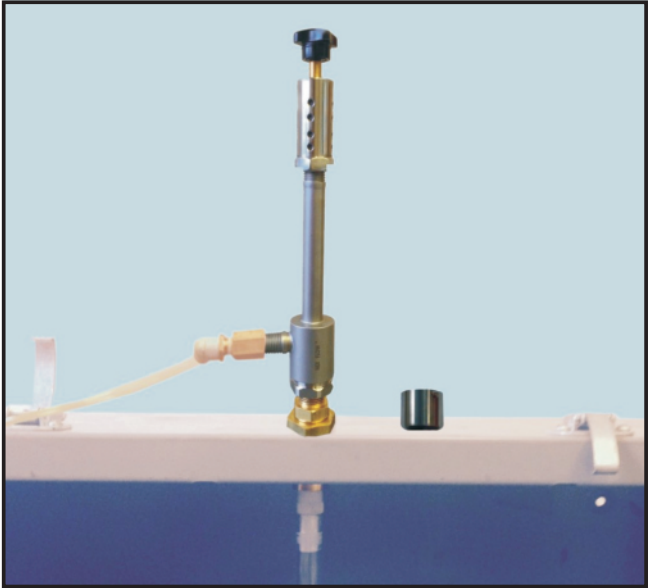

**List of parts:**

- Vortex Tube
- Hot and adjustable with screwdriver or with optional hand adjusting system
- Breather Cap with Lock Nut
- Connecting assembly to box
- Adaptor and hose barb for hose kit
- Optional hose distribution kit

**FRIGID-X BOX COOLER ADVANTAGES:**

- No moving parts
- Maintenance Free Operation
- Compact & Easy to Install
- Cooling Capacities to 2900 BTU/hr.
- No CFC's or HCFC's
- Stainless Steel Construction
- No Electricity
- Adjustable Cold Temperatures



**FRIGID-X™ BOX COOLER SYSTEM – HOW IT WORKS**

Compressed air enters at point (A) into the vortex tube. The vortex tube splits the compressed air into a hot (B) & cold (C) stream of air. The hot air from the vortex tube is vented to the atmosphere at point (D). Hot air displaced from the box is vented out through the breather cap (E). Cold air enters the box at point (F) or via an optional hose distribution kit (G).

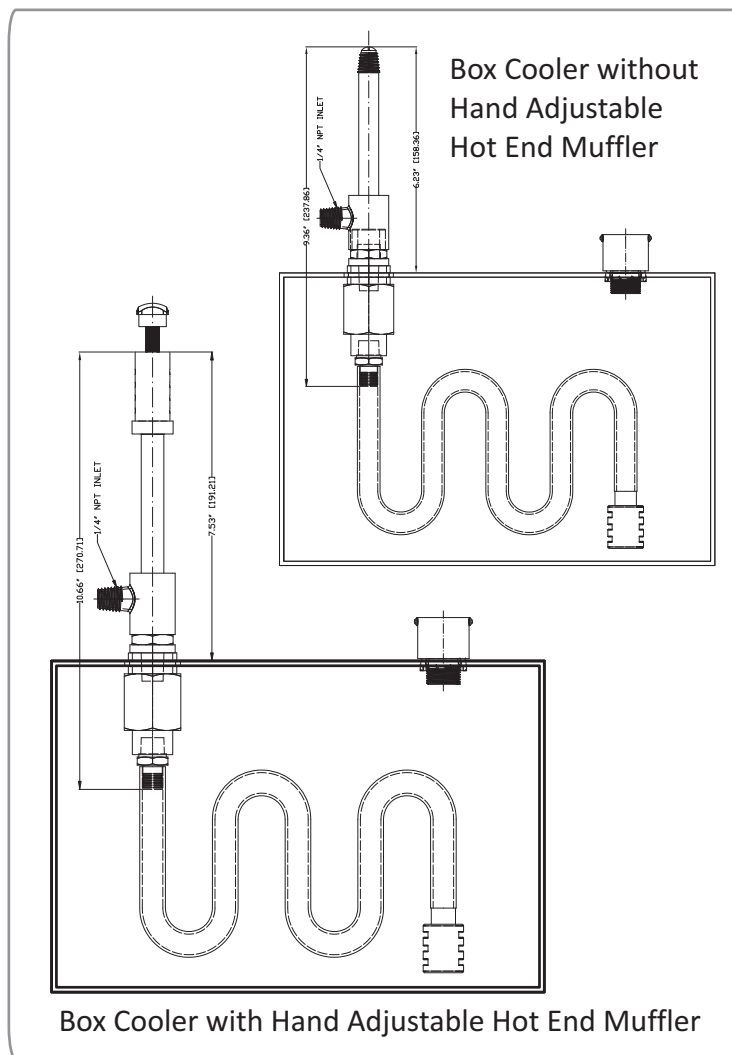
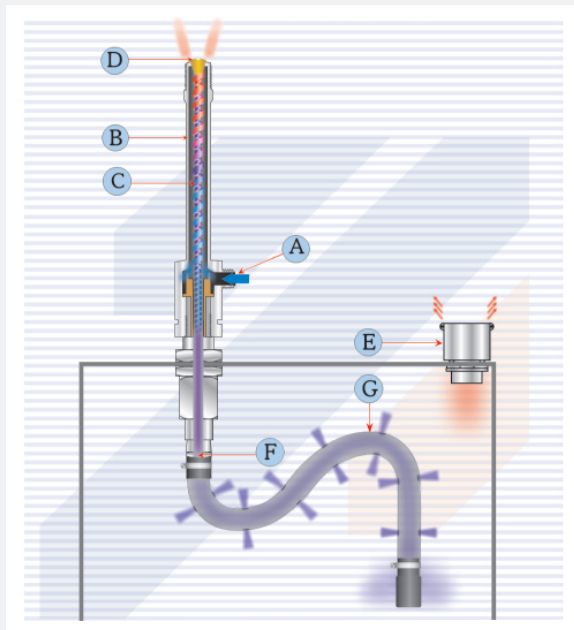

**FRIGID-X™ BOX COOLER SYSTEMS**

Part No.	Description
50010B	Box Cooler System with hot end adjustable screw 730 BTU/hr. 170 Watts
50015B	Box Cooler System with hot end adjustable screw 1100 BTU/hr. 322Watts
50025B	Box Cooler System with hot end adjustable screw 1800 BTU/hr. 527 Watts
50030B	Box Cooler System with hot end adjustable screw 2100 BTU/hr. 615 Watts
50040B	Box Cooler System with hot end adjustable screw 2900 BTU/hr. 849 Watts
52010B	Box Cooler System with hot end hand adjustable knob 730 BTU/hr. 170 Watts
52015B	Box Cooler System with hot end hand adjustable knob 1100 BTU/hr. 322Watts
52025B	Box Cooler System with hot end hand adjustable knob 1800 BTU/hr. 527 Watts
52030B	Box Cooler System with hot end hand adjustable knob 2100 BTU/hr. 615 Watts
52040B	Box Cooler System with hot end hand adjustable knob 2900 BTU/hr. 849 Watts

**ACCESSORIES**

Part No.	Description
69004	Hose Distribution Kit
55003	Hot End Muffler for Vortex Tube with hot end adj. screw
90004	Filter with Auto Drain
90015	Thermostat and Solenoid Valve Kit for On-Off Control

FRIGID-X™ VORTEX TUBES & SPOT COOLING





## FRIGID-X™ TOOL COOLING SYSTEM

Produce cold air from compressed air to cool machine tools and other applications to replace messy misting systems, improve product quality and increase production speeds

### WHAT ARE THEY - REASONS TO USE

Frigid-X™ Tool Cooling System for dry machining applications - replaces polluting and often toxic mist systems to improve dry machining operations. No mess, no residue and low in cost. It is efficient and can improve dry machining operations and assist in spot cooling applications for a variety of industrial machining processes by increasing machining rates and extending tool life. Produces cold air at approximately 50° F (28° C) below supply air temperature. The unit is muffled for quiet operation. No moving parts assures long life, maintenance free operation while extending tool life and improving production rates. It can prevent smearing of metal or plastics and eliminates wheel loading. Factory set for optimum cooling effect and to prevent freeze up. Can often replace costly mist coolants and certainly improves the quality and output of all types of dry machining operations from metals to plastics. Unit is low cost, no electricity with no moving parts and is essentially maintenance free.

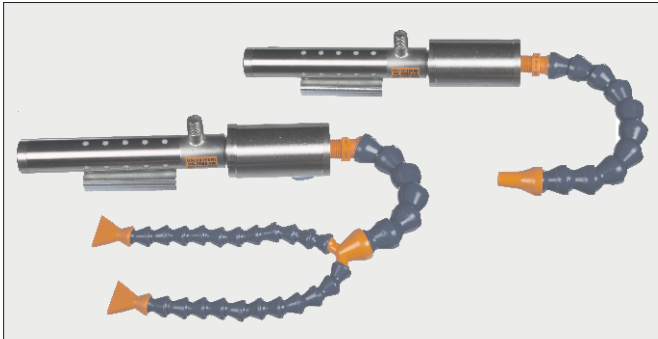

### FRIGID-X™ TOOL COOLER APPLICATIONS:

- ▶ Sharpening Tools
- ▶ Routing
- ▶ Machining Plastics
- ▶ Drill and cutter grinding
- ▶ Milling, Drilling, Routing and Surface Grinding
- ▶ Plunge & Form Grinding
- ▶ Setting Hot Melt Adhesives
- ▶ Laser Cutting
- ▶ Tire and Rubber Grinding
- ▶ Band Saw Blade Cooling
- ▶ Chill Roll Nip Cooling

### WHY THE FRIGID-X™ TOOL COOLER OVER OTHERS :

All Metal Parts, Stainless Steel Body. Tests Show Frigid-X™ consistently quieter than competition!

### FRIGID-X™ ADJUSTABLE SPOT COOLER ADVANTAGES:

- ▶ No moving parts.
- ▶ Quiet
- ▶ Driven by air not electricity.
- ▶ Small and lightweight - portable.
- ▶ Low in cost compared to most others
- ▶ Superior design and performance
- ▶ Maintenance free operation
- ▶ Made of durable stainless steel and metal arts – no cheap plastic parts
- ▶ Improves production rates and finished part remains dry
- ▶ Prevents burning
- ▶ Improves tolerance control
- ▶ Eliminates coolant costs
- ▶ System uses strong magnetic base

### FRIGID-X™ TOOL COOLER SYSTEM - HOW IT WORKS

Compressed air enters at point (A) into the vortex tube component of the tool cooling. The vortex tube splits the compressed air into a cold (B) and hot (C) stream of air. The hot air from the vortex tube is vented to the atmosphere at point (D) after being muffled to reduce noise. Cold air enters into the muffler (E) and then distributed through the hose distribution kit (F) and onto the tool being cooled. A strong magnet (G) holds the tool cooler onto the machine

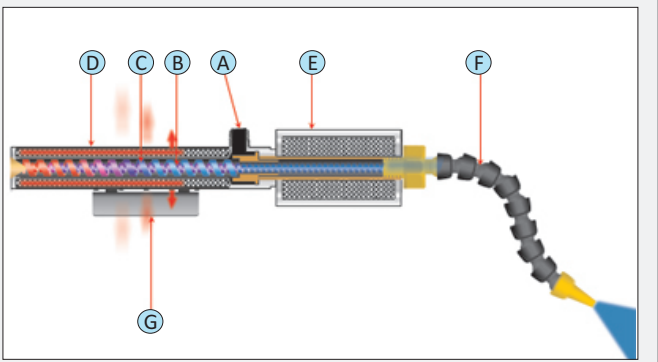

**FRIGID-X™ TOOL COOLING SYSTEM**

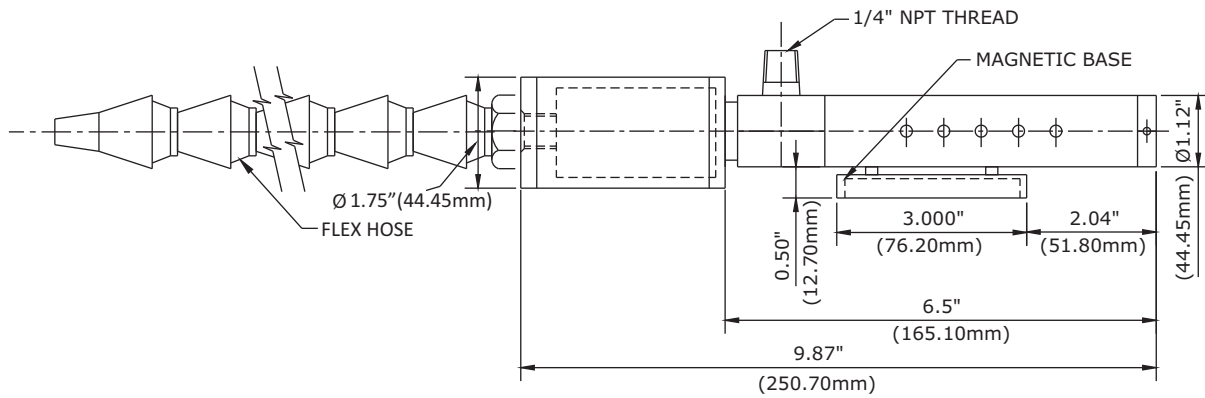

**FRIGID-X™ TOOL COOLING SYSTEM**

**SPECIFICATIONS**

MODEL NO.	INLET PRESSURE PSIG (Bar)	AIR CONSUMPTION SCFM (SLPM)	SOUND LEVEL dBA
57015FS, 57015FD	100 (6.9)	15 (425)	70
57025FS, 57025FD	100 (6.9)	25 (708)	78
57030FS, 57030FD	100 (6.9)	30 (850)	82
57040FS, 57040FD	100 (6.9)	40 (1133)	83

**Single Point Hose Kit**

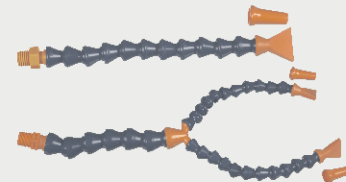

**Double Point Hose Kit**



A Model 57025FS Frigid-X™ Tool Cooler is used on a grinding application to reduce the heat and extend wheel life.

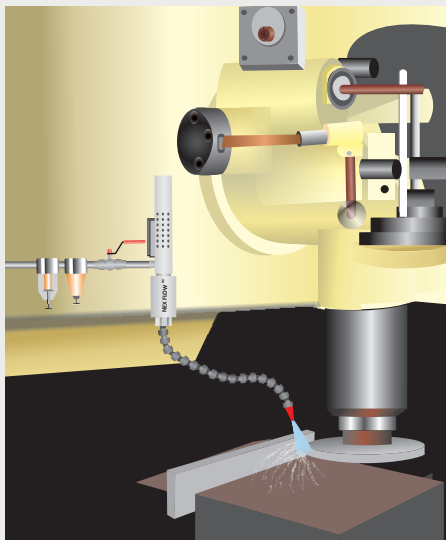

A Series of Model 57015FS Frigid-X™ Tool Coolers are used to cool the slitting cutters in a continuously moving paper roll slitting machine.

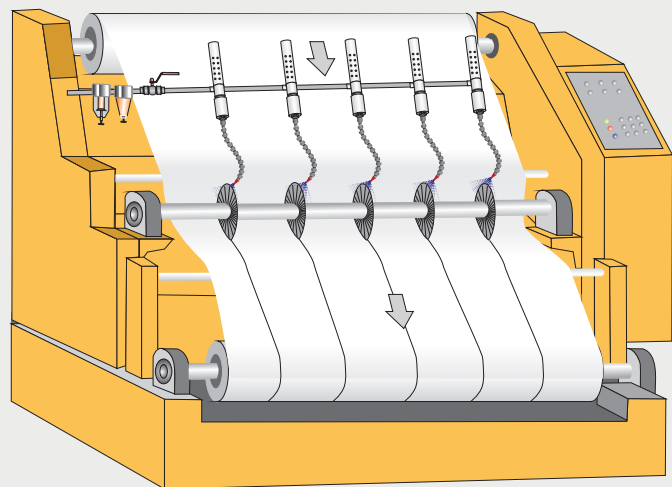

**USE AND SELECTION OF FRIGID-X™ TOOL COOLER**

Always use clean, dry compressed air. A manual filter is supplied with every 15 SCFM system and a filter with automatic drain with larger sizes to insure dry air. If oil is a major problem in the compressed air line, an oil removal filter is also recommended. The temperature of the air can be controlled by reducing the pressure using either a regulator or manual shut-off valve. A solenoid valve may also be connected into the machine operation to turn the air supply to the cooling unit on-off as it is needed, thereby conserving compressed air usage.

The tool cooler is available in several capacities - 15, 25, 30, and 40 SCFM in addition, there are two versions - a single point outlet and dual point outlet system.

The Single Point versions are used where a concentrated airflow is needed such as in drilling or grinding. The Dual point versions are used for applications where the heat to be removed is generated over larger surface areas such as in band sawing, milling, application of hot melt adhesives or on chill rolls. One system can be converted to the other by changing hose kits. For most applications the 15 SCFM units are satisfactory but for harder materials such as titanium, or faster machining speeds, the capacities used should be higher. The size depends on the application and an application engineer can assist you in choosing the right model.

**MODEL 57015FS**

Includes Tool Cooler Single, Point Hose Kit, 3/8" (10mm)  
Cone Nozzle, 1-1/4" (32mm)  
Fan Nozzle, Filter with Manual Drain

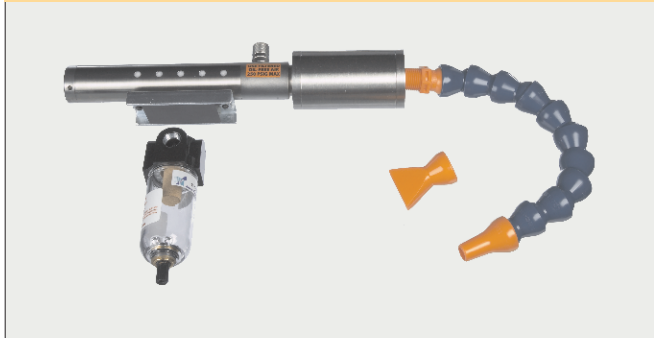

**MODEL 57015FD**

Includes Tool Cooler, Dual Point Hose Kit,  
Two (2) 1/4" (6mm) Cone Nozzle, 1" (25.4mm)  
Fan Nozzle, Filter with Manual Drain

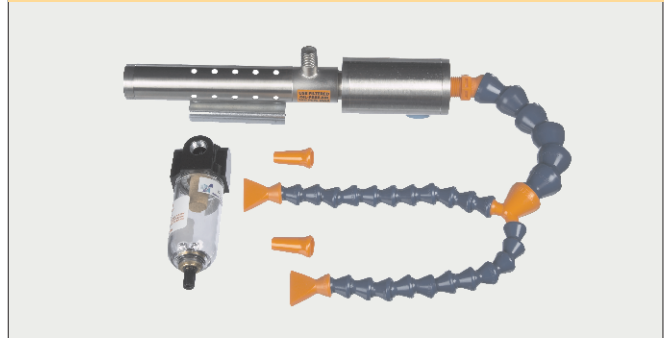

**MODEL 57025FS, 57030FS, 57040FS**

Includes Tool Cooler, Single Point Hose Kit, 3/8" (10mm)  
Cone Nozzle, 1-1/4" (32mm)  
Fan Nozzle, Filter with Automatic Drain

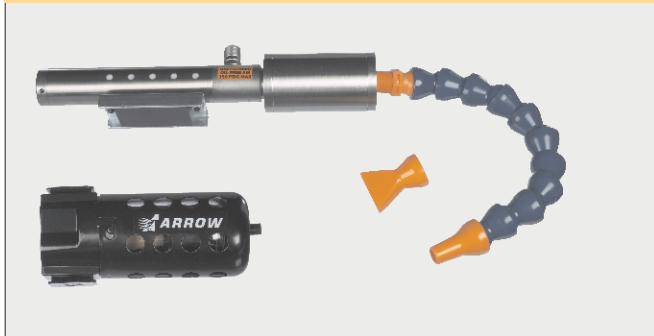

**MODEL 57025FD, 57030FD, 57040FD**

Includes Tool Cooler, Dual Point Hose Kit,  
Two (2) 1/4" (6mm) Cone Nozzle, 1" (25.4mm)  
Fan Nozzle, Filter with Automatic Drain

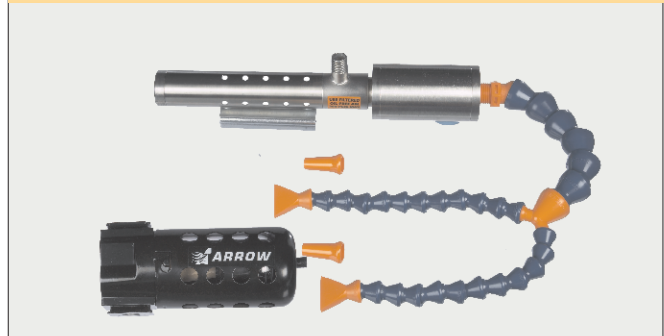

**FRIGID-X™ TOOL COOLING SYSTEM**

PART NO.	DESCRIPTION
56015F	Tool Cooler only - 15 SCFM Capacity - Standard Cooling Use
56025F	Tool Cooler only - 25 SCFM Capacity - Higher Cooling Use
56030F	Tool Cooler only - 30 SCFM Capacity - Very High Cooling Use
56040F	Tool Cooler only - 40 SCFM Capacity - Highest Cooling Use
57015FS	Tool Cooling System includes 15 SCFM Tool Cooler plus filter with manual drain and single point hose kit.
57015FD	Tool Cooling System includes 15 SCFM Tool Cooler plus filter with manual drain and dual point hose kit.
57025FS	Tool Cooling System includes 25 SCFM Tool Cooler plus filter with automatic drain and single point hose kit.
57025FD	Tool Cooling System includes 25 SCFM Tool Cooler plus filter with automatic drain and dual point hose kit.
57030FS	Tool Cooling System includes 30 SCFM Tool Cooler plus filter with automatic drain and single point hose kit.
57030FD	Tool Cooling System includes 30 SCFM Tool Cooler plus filter with automatic drain and dual point hose kit.
57040FS	Tool Cooling System includes 40 SCFM Tool Cooler plus filter with automatic drain and single point hose kit.
57040FD	Tool Cooling System includes 40 SCFM Tool Cooler plus filter with automatic drain and dual point hose kit.

**ACCESSORIES**

59001	Single Point Hose Kit - includes 3/8" (10 mm) cone nozzle and 1-1/4" (32 mm) fan nozzle
59002	Dual Point Hose Kit - includes two 1/4" (6 mm) cone nozzles and two 1" (25 mm) fan nozzles
90003	Manual filter -1/4" NPT, 27 SCFM (765 SLPM)
90004	Filter with automatic drain - 1/4" NPT, 43 SCFM (1359 SLPM)
90005	Oil Removal filter with automatic drain, 3/8" NPT, 15 to 37 SCFM (425 to 1048 SLPM)

**FRIGID-X™ TOOL COOLING SYSTEM**



## FRIGID-X™ SUB-ZERO VORTEX™ TOOL COOLING MIST SYSTEM

When lubrication is required as well as cooling, lubricating mist can be reduced and cooling enhanced

### WHAT ARE THEY - REASONS TO USE

Heavy coolant can be messy, costly and must be carefully maintained. In addition, dry machining is not always possible due to the need for lubrication or additional cooling that cold air alone cannot provide. The unique patent pending low cost **Frigid-X™ Sub-Zero Vortex™ Tool Cooling Mist System** is ideal for such applications. The unit is comprised of a coolant/lubricant suction system which draws any water based liquid into a specially designed delivery system. This cools the liquid to deliver a very cold fluid “mist” at around 40 degrees F (5 degrees C). This cooling allows for as much as 20% less coolant needed, faster production rates and improved quality.

### HOW IT WORKS:

The liquid is cooled by means of a small vortex tube that uses around 5 SCFM (142 SLPM) at a maximum of 50 psig (3.5 bar). Pressure can be adjusted up or down slightly to avoid freezing of the liquid or to get a colder temperature. An adjusting screw controls the level of mist required. Liquid is siphoned into the unit using a long plastic tube connected to the main unit. A heavy duty removable magnet secures the **Sub-Zero Vortex™ Tool Cooling Mist System** onto a machine. The magnet can also be removed and mounting holes may be used to secure the mist system. All you need is the liquid to cool and/or lubricate and a small amount of filtered (clean) compressed air at 50 psig (3.5 bar). No electrical components, no expensive pumps or moving parts except for the adjusting screw assures long life and maintenance free operation.



### Frigid-X™ Sub-Zero Vortex™ Advantages

- ▶ No electricity required – simplicity in design
- ▶ low cost
- ▶ reduces coolant/lubricant cost using by less fluid
- ▶ improves safety with less mist
- ▶ no moving parts except for an adjusting screw for the fluid
- ▶ small and lightweight, portable
- ▶ maintenance free operation

### Frigid-X™ Sub-Zero Vortex™ Advantages

- ▶ Solid Carbide End Mills
- ▶ wherever lubrication is required in machining
- ▶ when cooling is required beyond the capability of cold air alone

**SUB ZERO VORTEX™ TOOL COOLING SYSTEM**

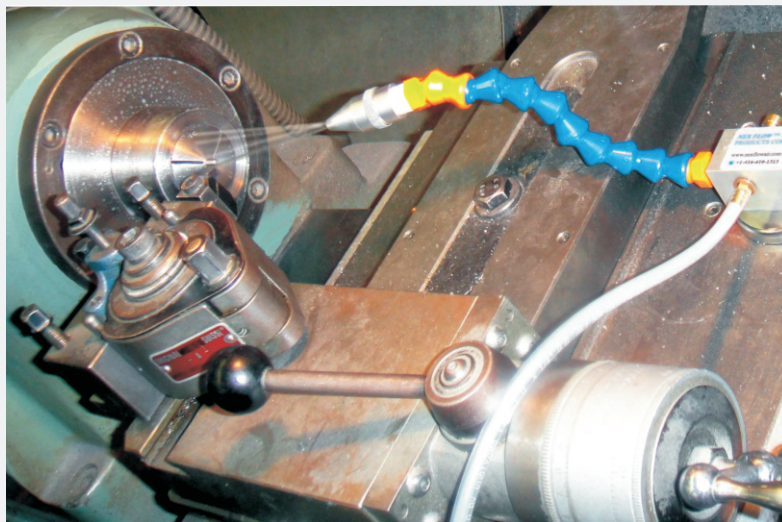
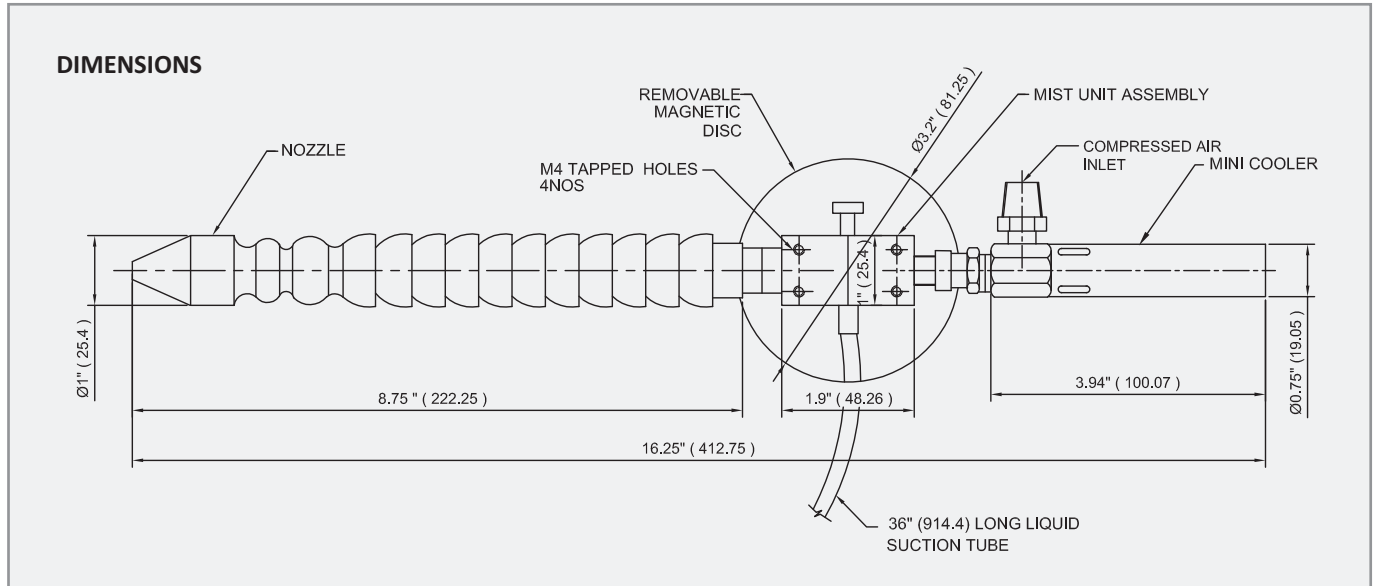

**MIST COOLANT & LUBRICANT**

The Frigid-X™ Sub-Zero Vortex™ Tool Cooling Mist System may use any water based material including water itself. Non-water based materials are not recommended as they may dry and clog the system. If you need a coolant/lubricant material Nex Flow can also supply:

PART NO.	DESCRIPTION
58LUBECOOL-1	Coolant/Lubricant in 4 X1 -gallon case (16 L)
58LUBECOOL-5	Coolant/Lubricant in 5 – gallon pail (20L)

**SUB ZERO VORTEX™ TOOL COOLING SYSTEM**

PART NO.	DESCRIPTION
58208	Sub Zero Vortex™ Mist Tool Cooling System C/w Mist Handling unit, Mini Cooler, Magnet
58008	Mist handling Unit only
99929L	Magnet Only
56008F	Mini Cooler Only

**ACCESSORIES**

90004	Filter with auto drain
90008	Regulator with gauge
90013	Manual Shutoff valve for vortex mini cooler - 1/8" NPT

**FRIGID-X™ TOOL COOLING SYSTEM**



## FRIGID-X™ PANEL COOLER

Prevent downtime due to overheating electric and electronic control panels and cabinets. FRIGID-X™ Panel Coolers maintain NEMA Type 12 (IP 54), NEMA Type 3R (IP 14) and Patented\* NEMA Type 4-4X (IP 66) integrity and are ULC Listed.

### WHAT ARE THEY - REASONS TO USE

Frigid-X™ Panel Cooler and Cabinet Enclosure Cooler for electronic control panels provide a low cost method of both purging and cooling electrical and electronic control panels by using a stainless steel vortex tube to create cold air from ordinary compressed air. Unlike many competitors - all of our coolers are stainless steel, not just the vortex tube, for longer life and flexible use. Frigid-X™ Panel Coolers are compact and can be installed in minutes through a standard electrical knockout. There are virtually no moving parts. Cabinet Enclosure Cooler - Frigid-X™ series are ideal for all NEMA Type 12 (IP 54), NEMA Type 3R (IP 14) and Patented\* NEMA Type 4-4X (IP 66) rated panels.

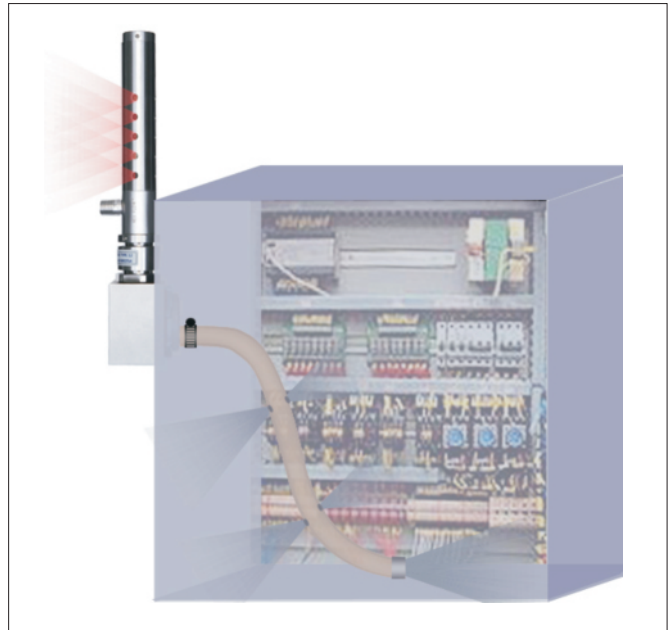

### FRIGID-X™ PANEL COOLER ADVANTAGES :

- ▶ No moving parts.
- ▶ Quiet
- ▶ Eliminate fans and blowers and filters
- ▶ Low in cost compared to most others
- ▶ Superior design and performance
- ▶ Maintenance free operation
- ▶ Made of durable stainless steel and metal parts - no cheap plastic parts
- ▶ Cooling capacities to 2800 BTU/Hr per unit.
- ▶ Maintain NEMA 12, NEMA 3R and Patented\* NEMA 4-4X integrity (IP 54, IP 14 and IP 66)
- ▶ Control and stabilize the temperature and humidity Inside the enclosure
- ▶ No CFC's or HCFC's
- ▶ Mount in a standard electrical knockout
- ▶ Eliminate circuit drift, nuisance tripping and dirt Contamination
- ▶ Provide wash down protection ( Patented\*NEMA 4-4X (IP 66) )

### WHY THE FRIGID-X™ PANEL COOLER OVER OTHERS :

All Metal Parts, Stainless Steel Body, Quiet, Tests Show Frigid-X™ Panel Cooler Constantly Quieter Than Competition! Our Standard units are good in ambient temperatures up to 150° F (67° C). High temperatures units are available to 200° F (93° C) and higher. Non Hazardous purge units are also available where constant flow is required to purge a control panel but maintain on-off operation to conserve energy. Contact Nex Flow™ or your local representative for details.

### FRIGID-X™ PANEL COOLER APPLICATIONS :

- ▶ Programmable controllers
- ▶ System Control Cabinets
- ▶ CCTV Cameras
- ▶ Motor Control Centers
- ▶ Relay Panels
- ▶ CNC Machine controls
- ▶ Computer Panels
- ▶ Laser Housing enclosure cooling
- ▶ Electronic scale cooling
- ▶ Modular Control Centers
- ▶ Food Service Equipment Controls



\*US patent number 8,616,010. Other countries: Patented or Patent Pending.

**CABINET ENCLOSURE TEMPERATURE WARNING LABEL**

For Qualitative Warning of Possible Over Heating of Electrical and Electronic Enclosures, by Nex Flow™ Air Products Corp. [www.nexflowair.com](http://www.nexflowair.com) or [www.nex-flow.com](http://www.nex-flow.com)

**95°F or 35°C**  
WARNING HIGH TEMPERATURE

If this label turns ORANGE, it is very hot inside this control panel and this heat may cause damage to electrical and electronic components inside. Please check and correct as soon as possible to avoid potential damage.

**106°F or 41°C**  
DANGER EXTREME HIGH TEMPERATURE

If this label turns RED, then the heat inside the panel is extremely hot and can cause serious damage to electrical and electronic components inside. Please check and correct without delay to avoid potential damage.

Temperature indicated is from the outside surface of the panel and temperature inside may actually be slightly more or less. If label indicates warning please check the inside for overheating conditions that may cause damage. If label indicates danger level of possible very hot temperature please address the problem immediately. Please contact Nex Flow™ Air Products Corp. or their local representative to address to Cabinet Enclosure Cooling needs.

Web Site: [www.nexflowair.com](http://www.nexflowair.com) or [www.nex-flow.com](http://www.nex-flow.com)

USA AND CANADA: 1-877-797-2777 INTERNATIONAL: +1 416 410-1313

NOTE: This Label is designed to indicate surface temperature only and only to be used as a guide. Proper instrumentation should be used to verify inside temperatures.

**With every Panel Cooler you receive a Free Panel Cooler Temperature Warning Indicator Sticker. It will provide a dual qualitative warning level and danger level if the temperature inside your control cabinet is too high. Use on any control panels you wish to monitor. Extra stickers may be purchased from NexFlow - Part Number 69600.**

**FRIGID-X™ PANEL COOLER**

**FRIGID-X™ PANEL COOLER SYSTEM - HOW IT WORKS**

Compressed air enters at point (A) into the vortex tube component of the panel cooler. The vortex tube splits the compressed air into a hot (B) and cold (C) stream of air. The hot air from the vortex tube is vented to the atmosphere at point (D) after being muffled to reduce noise. Hot air displaced from inside the control panel or cabinet is exhausted through point (E). Cold air enters into the panel (F) via the cold distribution hose (G). Holes (H) are punched into the hose kit to deliver the cold air inside the panel where required. A muffler (I) further reduces the noise level of the exhausting air.

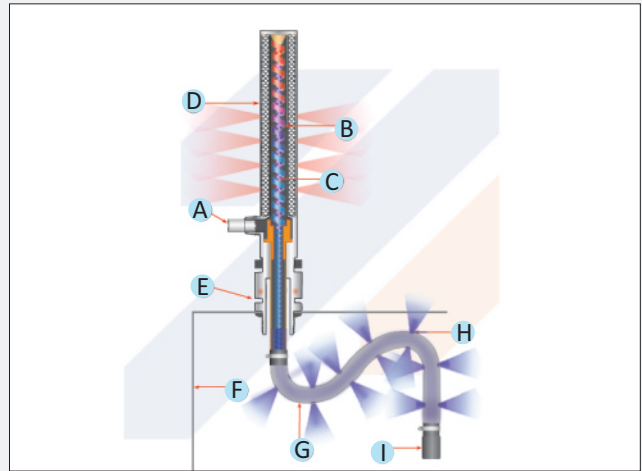

**Leaving a control panel door open to let a fan blow dirty hot air on to the control is hazardous and even illegal in many jurisdictions.**

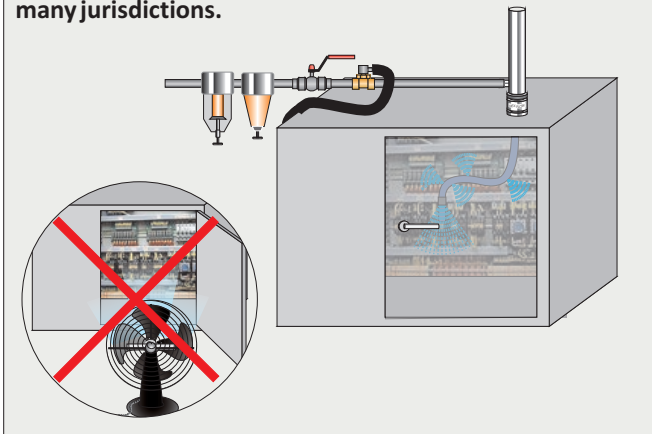

When you find control panel doors open it is a sure sign that you need Frigid-X™ Panel Cooler. Open doors are not only dangerous but also creates dirt buildup on electronics shortening their life.

**FRIGID-X™ PANEL COOLER SYSTEMS VERSES OTHER OPTIONS**

- ▶ Heat Pipes and air to air heat Exchangers cannot cool below ambient limiting cooling effect. Filters require Monitoring and change to prevent failure.
- ▶ Water cooled heat Exchangers use water which is not compatible with electrics. In addition scale buildup can cause reduced effectiveness over time and downtime for descaling.
- ▶ Refrigerant CFC or HCFC Heat Exchangers are more costly with higher installation cost and lower life expectancy Installation requires a floor drain for condensate. Machine vibration can cause loss of refrigerant and component failure. Average replacement cost of a compressor can be High. Filters require monitoring and change to prevent failure.
- ▶ Frigid-X™ Panel Cooler is low cost, with NEMA Type 12 (IP 54), NEMA Type 3R(IP 14 ) and Patented\* NEMA Type 4-4X (IP 66) Models available. They are compact, easy and fast to install. Thermostatic control minimizes air use to only when needed

**FRIGID-X™ PANEL COOLER SELECTION**

Nex Flow™ Frigid-X™ Panel Coolers are available with thermostat control (on-off units) or continuous operation. Continuous systems are best when constant cooling and/or a positive purge of the panel is required. On-off control saves air by activating the unit when the internal temperature approaches a critical level. The adjustable thermostat is factory set at 95 degrees F (35 degrees C). They are best used in applications where heat may fluctuate as in variable speed drives and where a continuous purge is not required. ALL OF OUR UNITS ARE STAINLESS STEEL for long life and flexible environments.

If a constant positive pressure is required with on-off control (Non-hazardous Purge Units) a special solenoid valve can be supplied to allow a small amount if air flow into the control panel when in the closed position. High temperature units for ambient in excess of 150° F (67° C) to 200° F (93° C) and higher are available.

**Frigid-X™ Panel Coolers are approved by Underwriters Laboratory (ULC Component Recognized) to meet USA and Canadian Standards, and meet CE Regulations and necessary international standards.**



\*US patent number 8,616,010. Other countries: Patented or Patent Pending.



**FRIGID-X PANEL COOLER SYSTEMS SPECIFICATIONS**

TYPE	MODEL	CAPACITY BTU/hr (Watts)*	Thermostat Control	Sound Level dBA
NEMA TYPE 12 (IP 54)	61004A	290 (85)	Not included	64
NEMA TYPE 12 (IP 54)	61008A	580 (170)	Not included	66
NEMA TYPE 12 (IP 54)	61015A	1100 (322)	Not included	72
NEMA TYPE 12 (IP 54)	61025A	1800 (527)	Not included	73
NEMA TYPE 12 (IP 54)	61030A	2100 (615)	Not included	74
NEMA TYPE 12 (IP 54)	61040A	2900 (849)	Not included	76
NEMA TYPE 12 (IP 54)	63004A	290 (85)	Included	64
NEMA TYPE 12 (IP 54)	63008A	580(170)	Included	66
NEMA TYPE 12 (IP 54)	63015A	1100 (322)	Included	72
NEMA TYPE 12 (IP 54)	63025A	1800 (527)	Included	73
NEMA TYPE 12 (IP 54)	63030A	2100 (615)	Included	74
NEMA TYPE 12 (IP 54)	63040A	2900 (849)	Included	76
NEMA TYPE 3R (IP 14)	61004R	290 (85)	Not included	64
NEMA TYPE 3R (IP 14)	61008R	580(170)	Not included	66
NEMA TYPE 3R (IP 14)	61015R	1100 (322)	Not included	72
NEMA TYPE 3R (IP 14)	61025R	1800 (527)	Not included	73
NEMA TYPE 3R (IP 14)	61030R	2100 (615)	Not included	74
NEMA TYPE 3R (IP 14)	61040R	2900 (849)	Not included	76
NEMA TYPE 3R (IP 14)	63004R	290 (85)	Included	64
NEMA TYPE 3R (IP 14)	63008R	580(170)	Included	66
NEMA TYPE 3R (IP 14)	63015R	1100 (322)	Included	72
NEMA TYPE 3R (IP 14)	63025R	1800 (527)	Included	73
NEMA TYPE 3R (IP 14)	63030R	2100 (615)	Included	74
NEMA TYPE 3R (IP 14)	63040R	2900 (849)	Included	76
Patented*NEMA TYPE 4-4X (IP 66)	61104X	290 (85)	Not included	64
Patented*NEMA TYPE 4-4X (IP 66)	61108X	580(170)	Not included	66
Patented*NEMA TYPE 4-4X (IP 66)	61115X	1100 (322)	Not included	72
Patented*NEMA TYPE 4-4X (IP 66)	61125X	1800 (527)	Not included	73
Patented*NEMA TYPE 4-4X (IP 66)	61130X	2100 (615)	Not included	74
Patented*NEMA TYPE 4-4X (IP 66)	61140X	2900 (849)	Not included	76
Patented*NEMA TYPE 4-4X (IP 66)	63104X	290 (85)	Included	64
Patented*NEMA TYPE 4-4X (IP 66)	63108X	580(170)	Included	66
Patented*NEMA TYPE 4-4X (IP 66)	63115X	1100 (322)	Included	72
Patented*NEMA TYPE 4-4X (IP 66)	63125X	1800 (527)	Included	73
Patented*NEMA TYPE 4-4X (IP 66)	63130X	2100 (615)	Included	74
Patented*NEMA TYPE 4-4X (IP 66)	63140X	2900 (849)	Included	76

**RATINGS EXPLANATION**

**NEMA TYPE 12 (IP 54)** Frigid-X™ Panel Cooler is dust tight and oil tight and used in general industrial environments.

**Patented\* NEMA TYPE 4-4X (IP 66)** Frigid-X™ Panel Cooler is dust, oil-tight, spray resistant and used in environments where there are liquids and for food service and corrosive environments.

**NEMA TYPE 3R (IP 14)** Frigid-X™ Panel Cooler is used in outdoor service.

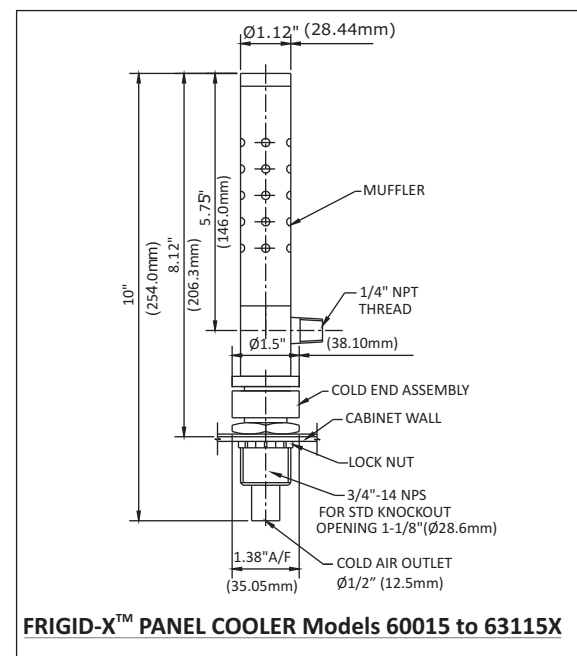
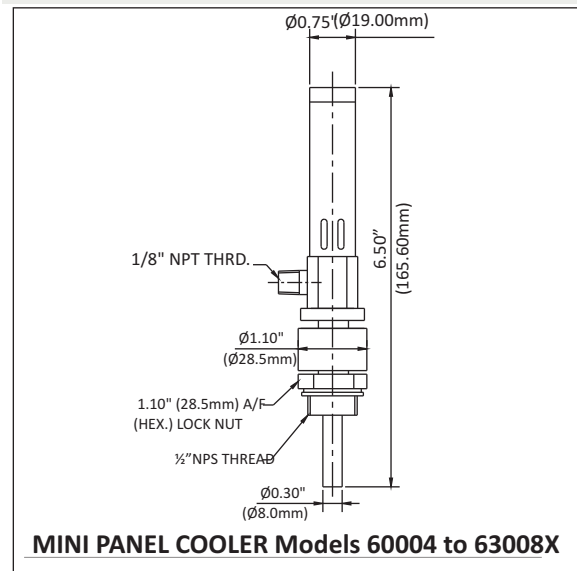

\* A) The BTU/hr (wattage) is calculated with air at 100 PSIG (6.9 Bar) and 70°F (21°C)

B) For temperatures of compressed air between 90°F (32°C) to 100°F (38°C) de-rate the cooling effect by 20% at 100°F (38°C) & above de-rate by 30%

\*US patent number 8,616,010. Other countries: Patented or Patent Pending.



**FRIGID-X™ PANEL COOLER**



## FRIGID-X™ HOT AND COLD MUFFLING KITS

Achieve additional noise level reduction utilizing the Frigid-X™ Hot end and Cold End Muffling Kits Combined dbA of up to 8 Decibels

### COLD END MUFFLING KIT

The Cold End Muffling Kit consists of a silencer and all necessary fittings to connect to the Panel Cooler at the cold air outlet inside the electrical control panel. Depending on the capacity of the specific Panel Cooler, the dbA reduction offered by the Cold End Muffling Kit is 5 to 6 dbA. Easy to install. Can be installed with the silencer vertical or horizontal depending on the space.

### HOT END MUFFLING KIT & HEAT GUARD

The Hot End Muffling Kit consists of an ABS Plastic sleeve with silencing material fitted over the hot end of the Panel Cooler, outside of the control panel. The dbA reduction offered by the Hot End Muffling Kit is 2 dbA. Easy to install just fit over the top of the Panel Cooler. In addition to noise reduction it offers additional protection from the hot end of the Panel Cooler.

PART NO	DESCRIPTION
69501	Cold End Muffler Kit for 60015A to 63140X
69503	Cold End Muffler Kit for 60004A to 63108X

PART NO	DESCRIPTION
69502	Hot End Muffler Kit for 60015A to 63140X
69504	Cold End Muffler Kit for 60004A to 63108X

**Cold End Muffler kits for Models for Models 60015A to 63140X (Large Size) and 60004A to 63108X Panel Coolers (Small size)**

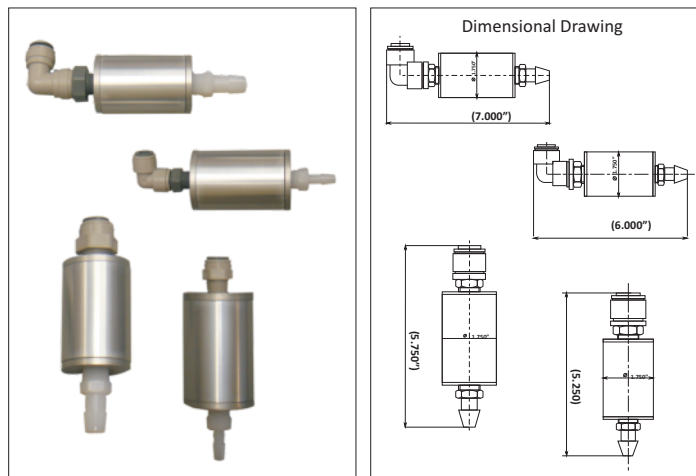

**Hot End Muffler kits for Models for Models 60015A to 63140X (Large Size) and 60004A to 63108X Panel Coolers (Small size)**

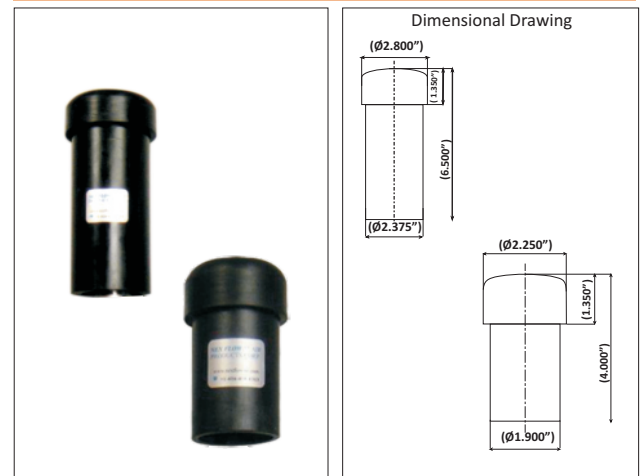

PART NO	DESCRIPTION
69505	Cold End and Hot End Combination Muffler Kit for 60015A to 63140X
69506	Cold End and Hot End Combination Muffler Kit for 60004A to 63108X



## SILENT X-STREAM™ FRIGID-X™ PANEL COOLER



Prevent Downtime due to overheating electric and electronic control panels and cabinets with Frigid-X™ Panel Coolers combined with the Hot and Cold End Muffling Kits for Quiet Operation Maintain NEMA Type 12 (IP 54), NEMA Type 3R (IP 14) and Patented\* NEMA Type 4-4x (IP 66) Integrity - ULC Listed

**WHAT ARE THEY - REASONS TO USE COMBINED WITH THE HOT AND COLD END MUFFLING KITS, THE SILENT X-STREAM™ PANEL COOLER CAN REDUCE NOISE LEVELS TO 64 dBA OR MORE.**

Frigid-X™ Panel Cooler and Cabinet Enclosure Cooler for electronic control panels provide a low cost method of both purging and cooling electrical and electronic control panels by using a stainless steel vortex tube to create cold air from ordinary compressed air. Unlike many competitors - all of our coolers are stainless steel, not just the vortex tube, for longer life and flexible use. Frigid-X™ Panel Coolers are compact and can be installed in minutes through a standard electrical knockout. There are virtually no moving parts. Cabinet Enclosure Cooler - Frigid-X™ series are ideal for all NEMA Type 12 (IP 54), NEMA Type 3R (IP 14) and Patented\* NEMA Type 4-4X (IP 56) rated panels.



### SILENT X-STREAM™ FRIGID-X™ PANEL COOLER ADVANTAGES :

- ▶ No moving parts.
- ▶ Put Extra Quiet
- ▶ Eliminate fans and blowers and filters
- ▶ Low in cost compared to most others
- ▶ Superior design and performance
- ▶ Maintenance free operation
- ▶ Made of durable stainless steel and metal arts -no cheap plastic parts
- ▶ Cooling capacities to 2800 BTU/Hr per unit.
- ▶ Maintain NEMA 12, NEMA 3R and Patented\* NEMA 4-4X integrity (IP 54, IP 14 and IP 66)
- ▶ Control and stabilize the temperature and humidity Inside the enclosure
- ▶ No CFC's or HCFC's
- ▶ Mount in a standard electrical knockout
- ▶ Eliminate circuit drift, nuisance tripping and dirt Contamination
- ▶ Provide wash down protection ( Patented\* NEMA 4-4X (IP 66) )

### WHY THE SILENT X-STREAM™ FRIGID-X™ PANEL COOLER OVER OTHERS:

The Panel Cooler itself is All Metal Parts, Stainless Steel Body, Extra Silenced using the Hot End Muffling Kit of ABS Plastic and Silencing material and a Cold End Silencer inside the Electrical Panel. Our Silent X-Stream units are good in ambient temperatures to 150 degrees F (67 degrees C.) Non-Hazardous purge units are also available where constant flow is required to purge a control panel but maintain on-off operation to conserve energy. Contact Nex Flow™ or your local representative for details.

### SILENT X-STREAM™ FRIGID-X™ PANEL COOLER APPLICATIONS:

- ▶ Computer Rooms
- ▶ Environments where Cooler Panels are in close proximity to Personnel
- ▶ When General Noise Reduction is Desired or Necessary

\*US patent number 8,616,010. Other countries: Patented or Patent Pending.



**SILENT X-STREAM™ FRIGID-X™ PANEL COOLER SYSTEM - HOW IT WORKS**

Compressed air enters at point (A) into the vortex tube component of the Panel Cooler. The vortex tube splits the compressed air into a hot (B) and cold (C) stream of air. The hot air from the vortex tube is vented out of the metal sleeve and down the hot end muffler and out at (D) after additional muffling. Hot air displaced from the inside of the control panel is exhausted through point (E). Cold Air enters into the panel (F) via the Cold End Muffler and hose distribution kit (G). Holes (H) are punched into the hose kit to deliver the cold air inside the panel where required. A muffler (I) further reduces the noise level of the exhausting air.

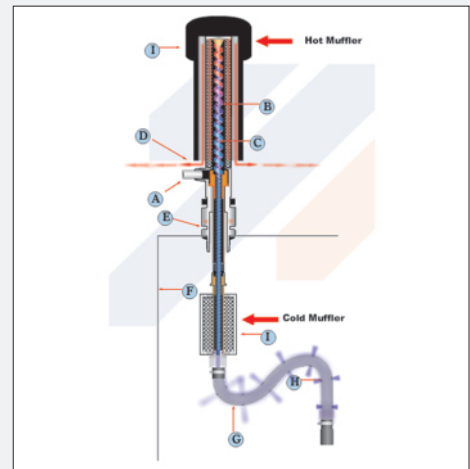

**Leaving a control panel door open to let a fan blow dirty hot air on to the control is hazardous and even illegal in many jurisdictions.**

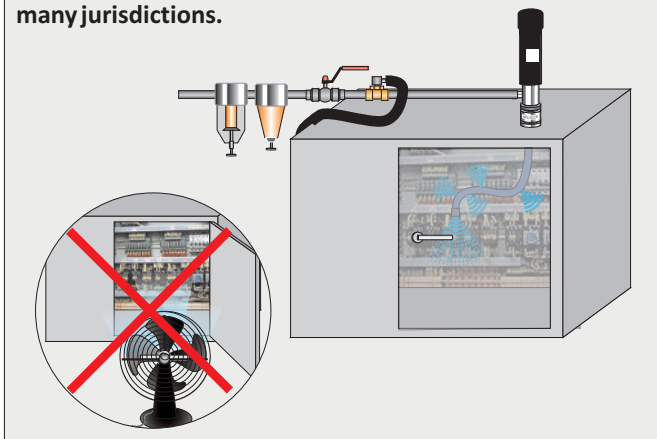

When you find control panel doors open it is a sure sign that you need Frigid-X™ Panel Cooler. Open doors are not only dangerous but also creates dirt buildup on electronics shortening their life.

**SILENT X-STREAM™ FRIGID-X™ PANEL COOLER**

- ▶ Heat Pipes and air to air heat Exchangers cannot cool below ambient limiting cooling effect. Filters require Monitoring and change to prevent failure.
- ▶ Water cooled heat Exchangers use water which is not compatible with electrics. In addition scale buildup can cause reduced effectiveness over time and downtime for descaling.
- ▶ Refrigerant CFC or HCFC Heat Exchangers are more costly with higher installation cost and lower life expectancy Installation requires a floor drain for condensate. Machine vibration can cause loss of refrigerant and component failure. Average replacement cost of a compressor can be High. Filters require monitoring and change to prevent failure.
- ▶ Frigid-X™ Panel Cooler is low cost, with NEMA Type 12 (IP 54), NEMA Type 3R(IP 14 ) and Patented\* NEMA Type 4-4X (IP 66) Models available. They are compact, easy and fast to install. Thermostatic control minimizes air use to only when needed

**SILENT X-STREAM™ FRIGID-X™ PANEL COOLER**

Nex Flow™ Frigid-X™ Panel Coolers are available with thermostat control (on-off units) or continuous operation. Continuous systems are best when constant cooling and/or a positive purge of the panel is required. On-off control saves air by activating the unit when the internal temperature approaches a critical level. The adjustable thermostat is factory set at 95 degrees F (35 degrees C). They are best used in applications where heat may fluctuate as in variable speed drives and where a continuous purge is not required. ALL OF OUR UNITS ARE STAINLESS STEEL for long life and flexible environments.

If a constant positive pressure is required with on-off control (Non-hazardous Purge Units) a special solenoid valve can be supplied to allow a small amount if air flow into the control panel when in the closed position. High temperature units for ambient in excess of 150° F (67° C) to 200° F (93° C) and higher are available.

**Frigid-X™ Panel Coolers are approved by Underwriters Laboratory (ULC Component Recognized) to meet USA and Canadian Standards, and meet CE Regulations and necessary international standards.**



\*US patent number 8,616,010. Other countries: Patented or Patent Pending.

## SILENT X-STREAM™ FRIGID-X™ PANEL COOLER SYSTEMS SPECIFICATIONS

TYPE	MODEL	CAPACITY BTU/hr (Watts)*	Thermo- stat Control	Sound Level dBA
NEMA TYPE 12 (IP 54)	61004A-X	290 (85)	Not included	58
NEMA TYPE 12 (IP 54)	61008A-X	580 (170)	Not included	60
NEMA TYPE 12 (IP 54)	61015A-X	1100 (322)	Not included	67
NEMA TYPE 12 (IP 54)	61025A-X	1800 (527)	Not included	68
NEMA TYPE 12 (IP 54)	61030A-X	2100 (615)	Not included	68
NEMA TYPE 12 (IP 54)	61040A-X	2900 (849)	Not included	69
NEMA TYPE 12 (IP 54)	63004A-X	290 (85)	Included	58
NEMA TYPE 12 (IP 54)	63008A-X	580(170)	Included	60
NEMA TYPE 12 (IP 54)	63015A-X	1100 (322)	Included	67
NEMA TYPE 12 (IP 54)	63025A-X	1800 (527)	Included	68
NEMA TYPE 12 (IP 54)	63030A-X	2100 (615)	Included	68
NEMA TYPE 12 (IP 54)	63040A-X	2900 (849)	Included	69
NEMA TYPE 3R (IP 14)	61004R-X	290 (85)	Not included	58
NEMA TYPE 3R (IP 14)	61008R-X	580(170)	Not included	60
NEMA TYPE 3R (IP 14)	61015R-X	1100 (322)	Not included	67
NEMA TYPE 3R (IP 14)	61025R-X	1800 (527)	Not included	68
NEMA TYPE 3R (IP 14)	61030R-X	2100 (615)	Not included	68
NEMA TYPE 3R (IP 14)	61040R-X	2900 (849)	Not included	67
NEMA TYPE 3R (IP 14)	63004R-X	290 (85)	Included	58
NEMA TYPE 3R (IP 14)	63008R-X	580(170)	Included	60
NEMA TYPE 3R (IP 14)	63015R-X	1100 (322)	Included	67
NEMA TYPE 3R (IP 14)	63025R-X	1800 (527)	Included	68
NEMA TYPE 3R (IP 14)	63030R-X	2100 (615)	Included	68
NEMA TYPE 3R (IP 14)	63040R-X	2900 (849)	Included	69
Patented*NEMA TYPE 4-4X (IP 66)	61104X-X	290 (85)	Not included	58
Patented*NEMA TYPE 4-4X (IP 66)	61108X-X	580(170)	Not included	60
Patented*NEMA TYPE 4-4X (IP 66)	61115X-X	1100 (322)	Not included	67
Patented*NEMA TYPE 4-4X (IP 66)	61125X-X	1800 (527)	Not included	68
Patented*NEMA TYPE 4-4X (IP 66)	61130X-X	2100 (615)	Not included	68
Patented*NEMA TYPE 4-4X (IP 66)	61140X-X	2900 (849)	Not included	69
Patented*NEMA TYPE 4-4X (IP 66)	63104X-X	290 (85)	Included	58
Patented*NEMA TYPE 4-4X (IP 66)	63108X-X	580(170)	Included	60
Patented*NEMA TYPE 4-4X (IP 66)	63115X-X	1100 (322)	Included	67
Patented*NEMA TYPE 4-4X (IP 66)	63125X-X	1800 (527)	Included	68
Patented*NEMA TYPE 4-4X (IP 66)	63130X-X	2100 (615)	Included	68
Patented*NEMA TYPE 4-4X (IP 66)	63140X-X	2900 (849)	Included	69

\*US patent number 8,616,010. Other countries: Patented or Patent Pending.

## RATINGS EXPLANATION

**NEMA TYPE 12 (IP 54)** Frigid-X™ Panel Cooler is dust tight and oil tight and used in general industrial environments.

**Patented\* NEMA TYPE 4-4X (IP 66)** Frigid-X™ Panel Cooler is dust, oil-tight, spray resistant and used in environments where there are liquids and for food service and corrosive environments.

**NEMA TYPE 3R (IP 14)** Frigid-X™ Panel Cooler is used in outdoor service.

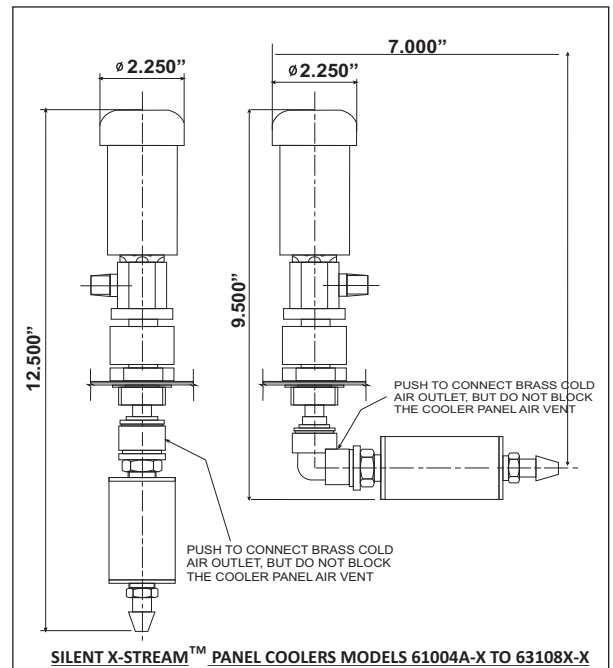
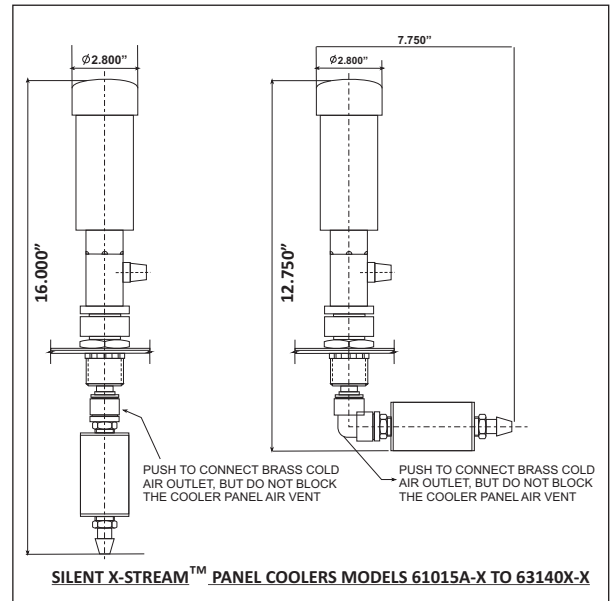

\* A) The BTU/hr (wattage) is calculated with air at 100 PSIG (6.9 Bar) and 70°F (21°C)

B) For temperatures of compressed air between 90°F (32°C) to 100°F (38°C) de-rate the cooling effect by 20% at 100°F (38°C) & above de-rate by 30%



**THE NEW ELC ELECTRONIC CONTROL DIGITAL THERMOSTAT**

The ELC (Electronic Control Digital Thermostat) is a way for precise control of one or two New Flow™ Frigid-X Panel Coolers. Far more accurate and elegant than using a standard thermostat and with flexible use.

**SPECIFICATIONS:**

- ▶ **Supply voltage :** AC 120-240V (24V on request)
- ▶ **Sampling rate :** 4/ sec (almost double that of our nearest competitor)
- ▶ **Accuracy :** 0.25% of full scale (under 10% of a degree)
- ▶ **3 Outputs :** 2 Relay outputs and one with PID, 1 SSR output with PID to control external SSR
- ▶ -50°C to + 100°C measuring range
- ▶ It has two Alarm settings for the two output relays so you can set two different temperatures to control two separate solenoids for two separate coolers (and can be used to control anything else electrical)
- ▶ Auto tune mode for quick set ups
- ▶ Patented\* NEMA Type 4-4X Enclosure (ABS/PC), ULC approved- it is accepted anywhere in the world
- ▶ Standard unit comes with one solenoid valve
- ▶ Fahrenheit or Centigrade and easily switchable back and forth
- ▶ It can be used in conjunction with the new PLCFC Optimization system for special applications such as cooling parts on a conveyor or in a tunnel, to control cooling and to index movement of the parts being conveyed (See Section A).

**ELC Electronic Control Digital Thermostat**

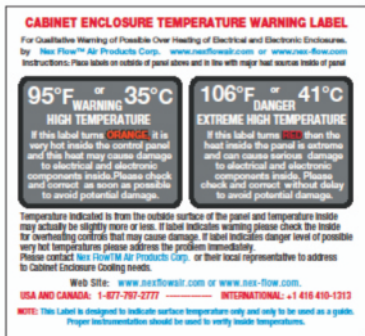
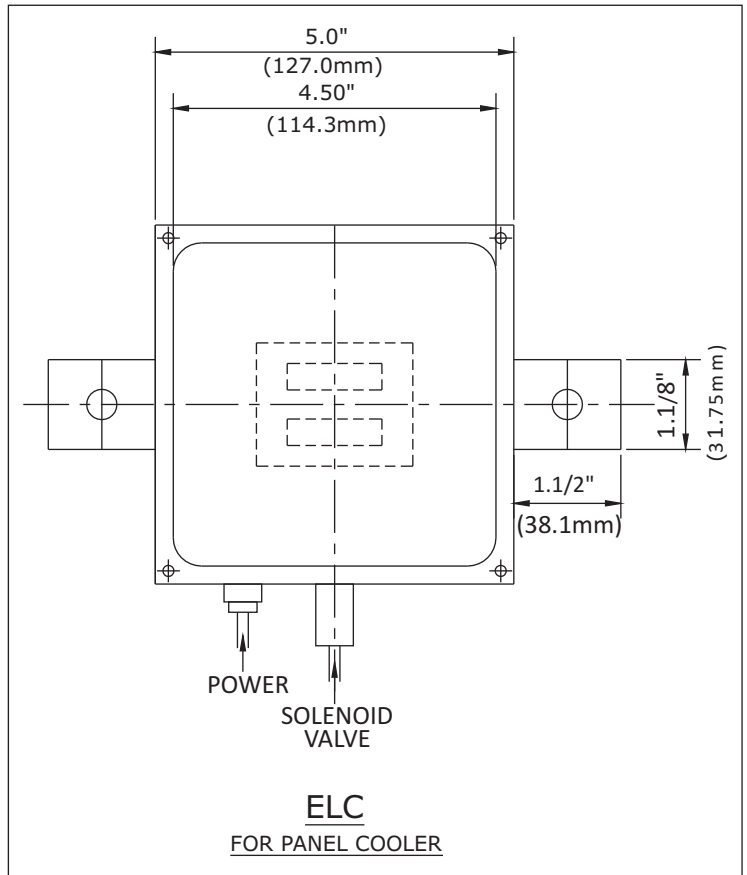

With every Panel Cooler you receive a Free Panel Cooler Temperature Warning Indicator Sticker. It will provide a dual qualitative warning level and danger level if the temperature inside your control cabinet is too high. Use on any control panels you wish to monitor. Extra stickers may be purchased from NexFlow - Part Number 69600.



**CALCULATING HEAT LOAD IN YOUR ELECTRICAL/ELECTRONIC PANEL ENCLOSURE:**
**Useful terms and conversions :**

- ▶ 1 BTU/hr = 0.293 watts                      ▶ 1 horsepower = 2544 BTU/hr            ▶ 1 Square Foot = 0.0929 square meters
- ▶ 1 BTU/hr - 0.000393 horsepower       ▶ 1 Watt = 0.00134 horsepower       ▶ 1 Square Meter = 10.76 square foot
- ▶ 1 Watt = 3.415 BTU/hr

**Typical fan capacity :**

- ▶ 4" fan: 100 CFM (2832 LPM)                ▶ 8" fan: 340 CFM (9628 LPM)
- ▶ 6" fan: 220 CFM (6230 LPM)               ▶ 10" fan: 550 CFM (15574 LPM)

Total heat load consists of the heat transfer from outside your panel and from the heat dissipated inside the control unit.

BTU/hr cooling effect from fan  $1.08 \times (\text{temp. inside panel in } ^\circ\text{F} - \text{temp. outside panel in degrees F}) \times \text{CFM}$

Watts cooling effect from fan:  $0.16 \times (\text{temp. inside panel in } ^\circ\text{C} - \text{temp. outside panel in degrees C}) \times \text{LPM}$

**CALCULATING BTU/hr OR Watts:**

1. Determine the heat generated inside the enclosure. Approximations may be necessary. For example, if you know the power generated inside the unit, assume 10% of the energy is dissipated as heat.
2. For heat transfer from the outside, calculate the area exposed to the atmosphere except for the bottom of the control panel.
3. Choose the internal temperature you wish to have, and choose the temperature difference between it and the maximum external temperature expected.
4. From the conversion table that follows, determine the BTU/hr per square foot (or watts per square meter) for the temperature difference.
5. Multiply the panel surface area times the BTU/hr per square foot (or watts per square meter) to get the external heat transfer in BTU/hr or in watts.
6. Sum the internal and external heat loads calculated.
7. If you do not know the power used in the enclosure but you can measure temperatures, then measure the temperature difference between the outside at current temperature, and the present internal cabinet temperature.
8. Note size and number of any external fans. Provide this information to Nex Flow™ to assist in sizing the appropriate cooling system.

Temperature Difference In $^{\circ}\text{F}$	BTU/hr/sq. Ft.	Temperature Difference In $^{\circ}\text{C}$	Watts/sq. meter
5	1.5	3	5.2
10	3.3	6	11.3
15	5.1	9	17.6
20	7.1	12	24.4
25	9.1	15	31.4
30	11.3	18	39.5
35	13.8	21	47.7
40	16.2	24	55.6



**Example :**

The control panel has two frequency drives totaling 10 horsepower and one module rated at 100 watts. The maximum outside temperature expected is 105°F or 40.5°C. The area of the control panel exposed sides, except for the top is 42 square feet or 3.9 square meters. We want the internal temperature to be 95°F or 35°C.

Total internal power is 10 hp x 746 watts/hp - 7460 plus 100 watts = 7560 watts.

Assume 10% forms heat = an internal heat load of 756 watts

Total internal power is 10 hp x 2544 BTU/hp = 25440 BTU/hr plus 100 watts x 3.415 BTU/hr/Watt = 25782 BTU/hr

Assume 10% forms heat = an internal heat load of 2578 BTU/hr

External heat load: The temperature difference between the desired temperature and the outside is 10°F or 5.5°C. Using the conversions (and interpolating where necessary) we multiply the area by the conversion factor:

42 sq. ft x 3.3 - 139 BTU/hr or 3.9 sq. m x 10.3 = 40 Watts

Total Heat Load: 756 + 40 - 796 watts or 2578 + 139 - 2717 BTU/hr

You would use a Model 61040 for constant operation or a Model 63040 for one-off control. (Rated at 2900 BTU/hr or 849 Watts).

**Copy and FAX to +1-877-797-2660 international FAX: +1-416-410-1806**

NAME: \_\_\_\_\_  
 COMPANY: \_\_\_\_\_  
 TELEPHONE: \_\_\_\_\_  
 FAX: \_\_\_\_\_ EMAIL: \_\_\_\_\_

HEIGHT: \_\_\_\_\_ Inches or mm  
 WIDTH: \_\_\_\_\_ Inches or mm  
 DEPTH: \_\_\_\_\_ Inches or mm

EXTERNAL TEMPERATURE NOW: \_\_\_\_\_ F or C  
 MAX. EXTERNAL TEMPERATURE EXPECTED: \_\_\_\_\_ F or C  
 CURRENT INTERNAL TEMPERATURE: \_\_\_\_\_ F or C  
 MAXIMUM INTERNAL TEMPERATURE DESIRED: \_\_\_\_\_ F or C

RATING:  NEMA 12 (IP 54)  NEMA 4-4X (IP 66)  NEMA 3R(IP 14)  OTHER (Specify) \_\_\_\_\_

Check if applicable:  Free Standing  Wall Mounted  
 Vented to allow outside air to circulate inside  
 Not vented so outside air does not circulate inside  
 Has External fans  How many? \_\_\_\_\_ Size of fan or SCFM/SLPM ea

Please complete and FAX and an application engineer will respond within 24 hours

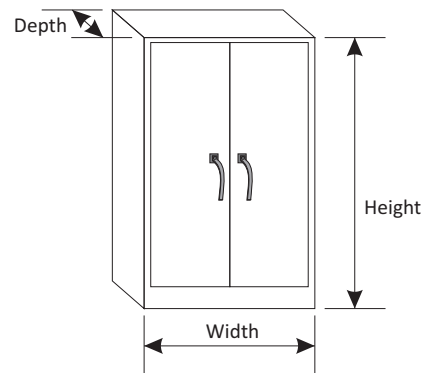



### ACCESSORIES :

PART NO.	DESCRIPTION	PART NO.	DESCRIPTION
69004	Cold Air Distribution Kit for all all sizes except 580 BTU/hr capacity and smaller	90044	NEMA Type 12 (IP 54) Solenoid Valve and Thermostat Kit (240V, 50 / 60 hz)
69005	Cold Air Distribution Kit for 580 BTU/hr capacity and smaller	90016	NEMA Type 4-4X (IP 66) and NEMA Type 3R (IP 12) Solenoid Valve and Thermostat Kit (120 V, 50 / 60 hz)
90004	Filter with auto drain, 43 SCFM (1359 SLPM), 1/4 " NPT	90045	NEMA Type 4-4X (IP 66) and NEMA Type 3R (IP 12) Solenoid Valve and Thermostat Kit (240 V, 50 / 60 hz)
90005	Oil Removal Filter, 3/4 " NPT for all sizes, 37 SCFM (1048 SLPM), 3/8 " NPT	90017	Thermostat only
90008	Pressure Regulator c/w gauge, 50 SCFM (1416 SLPM), 1/4" NPT	90038	Electronic Temperature Control, (120V, 50 / 60 hz), 1/4 " NPT
90015	NEMA Type 12 (IP 54) Solenoid Valve and Thermostat Kit (120V, 50 / 60 hz)	90039	Electronic Temperature Control, (240V, 50 / 60 hz), 1/4 " NPT
69600	Panel Cooler Temperature Warning Indicator Stickers		

### IMPORTANCE OF FILTRATION, HOSE DISTRIBUTION KIT, SEALING & MOUNTING

All Nex Flow™ Frigid-X™ Panel Cooler systems are supplied with a 5 micron filter c/w automatic float type drain and a hose distribution kit. The hose kit comes complete with a length of flexible vinyl clear tube which is used to direct the cold air to hot spots in the enclosure and to circulate the cold air. Clamps to hold the tubing and a silencing muffler, also supplied, are supplied along with adhesive backed clips to hold the tubing in place. The hose kit and muffler further reduce noise levels but also act as an emergency trap for moisture should the filter fail or any reason, protecting your enclosure controls. The filter protects against moisture and in fact stops all moisture from entering the control panel. The air entering the panel goes from high pressure to near atmospheric conditions and will stabilize at 45% relative humidity. For this reason, Nex Flow™ Frigid-X™ Panel Cooler systems are usable for humidity control as well as cooling - truly an "air conditioner". If there is a potential for oil in the air lines our Model 90005 oil removal filter (to 0.3 micron) is recommended. Nex Flow™ Frigid-X™ Panel Coolers should be mounted on the top or side (using our side mount kits) but near the top as much as possible. All panel coolers should be mounted vertical as well.

#### HOSE DISTRIBUTION KIT for Medium Size Panel Coolers Models 60015A to 63140X



#### HOSE DISTRIBUTION KIT for Small Size Panel Coolers Models 60004A to 63108X

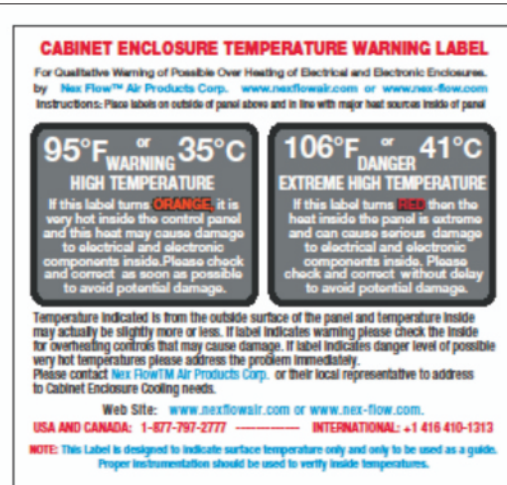

With every Panel Cooler you receive a Free Panel Cooler Temperature Warning Indicator Sticker. It will provide a dual qualitative warning level and danger level if the temperature inside your control cabinet is too high. Use on any control panels you wish to monitor. Extra stickers may be purchased from NexFlow - Part Number 69600.



**SOLENOID VALVE AND THERMOSTAT**

Nex Flow™ Frigid-X™ Panel Cooler systems are available with a standard 2-way normally closed solenoid valve and thermostat kit Model 90015 (120V) or Model 90016 (230V). This limits the flow of air only when required. The thermostat is factory set at 95 degrees F (35 C) and will normally hold +/- 2 degrees F (1 C) inside the enclosure. It is rated 24V-240V, 50/60 Hz. UL recognized and CSA approved.

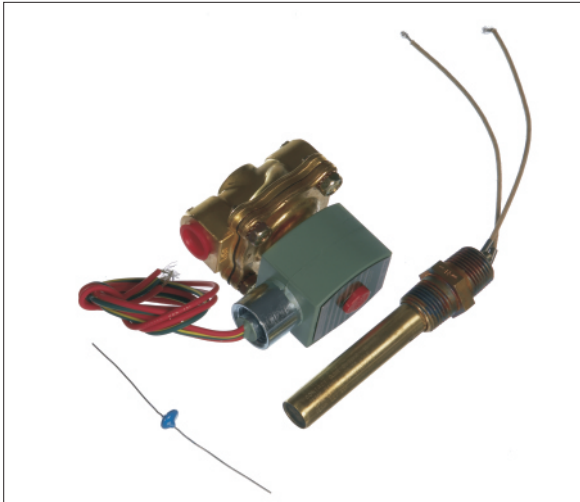

**Thermostat and Solenoid Valve Kit :** The kit comes complete with a solenoid valve, thermostat and a resistor. The resistor is included should you encounter rapid temperature fluctuations in the control panel causing the solenoid to cycle on and off too quickly (chattering). The resistor is installed (if needed) across the leads of the thermostat and prevents chattering by dampening the thermo switch sensitivity.

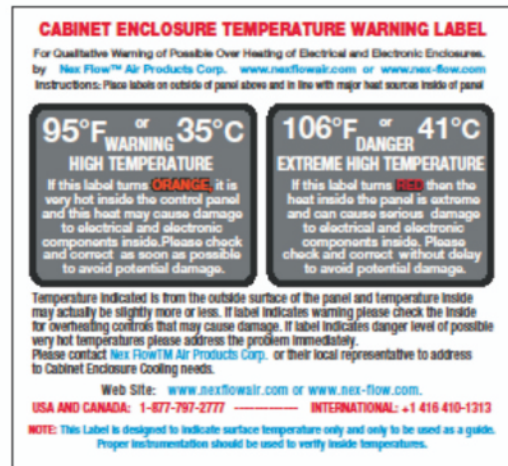

With every Panel Cooler you receive a Free Panel Cooler Temperature Warning Indicator Sticker. It will provide a dual qualitative warning level and danger level if the temperature inside your control cabinet is too high. Use on any control panels you wish to monitor. Extra stickers may be purchased from NexFlow - Part Number 69600.



**Continuous cooling system with cooler, filter with auto drain and hose distribute Kit.**

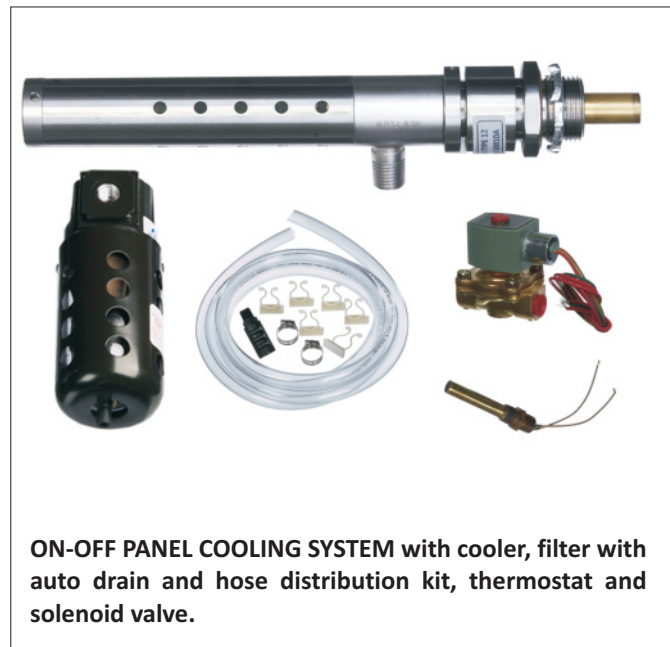

**ON-OFF PANEL COOLING SYSTEM with cooler, filter with auto drain and hose distribution kit, thermostat and solenoid valve.**

**FRIGID-X™ PANEL COOLER**

**FOR TIGHT SPACES - USE OUR SIDE MOUNT KITS**

The Nex Flow™ Frigid-X™ Panel Cooler systems are normally mounted on the top of the enclosure but if space does not permit, you can utilize the Side Mount Kits. Made of stainless steel for NEMA 12(IP 54), NEMA 3R(IP 14) or Patented\* NEMA 4-4X(IP 66) environments, they are designed for use with all Frigid-X™ Panel Coolers. Two sizes are available – one for coolers 8 SCFM and under capacity and the other for the larger size coolers. Slim design to minimize space even when mounted on the side of a panel.

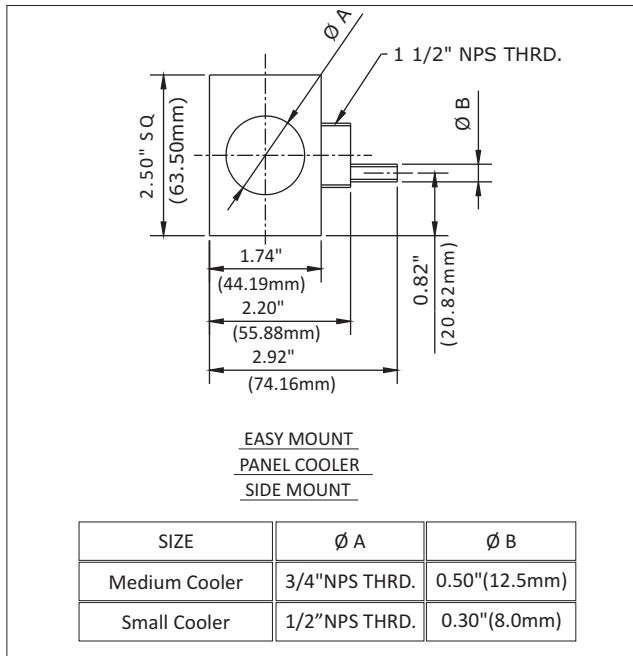

Easy Mount Side Mount are available for the small & medium size Panel Coolers to allow mounting to the side of an enclosure if space prevents mounting on the top. It is a “plug and play” system

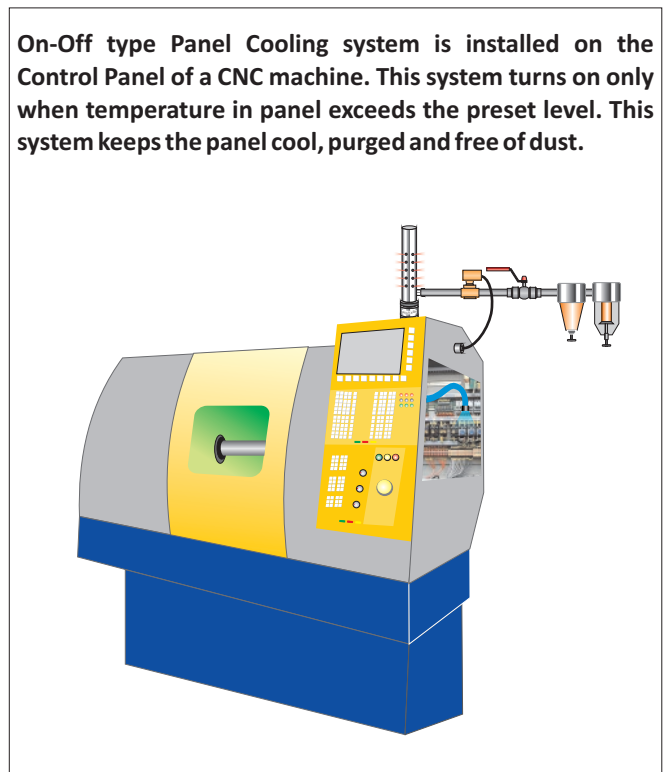

\*US patent number 8,616,010. Other countries: Patented or Patent Pending.

PART NO.	DESCRIPTION
69100	Stainless steel easy mount side mount for all panel coolers models 60004A to 63018X
69200	Stainless steel easy mount side mount for all panel coolers models 60015A to 63140X



**NEMA Type 12 (IP 54) Continuous Operation C/W Filter and Hose distribution kit**

**NEMA Type 12 (IP 54) On-off Operation C/W Filter, Hose distribution kit, Solenoid Valve & Thermostat**

**NEMA Type 12 (IP 54) Panel Cooler Only**

PART NO.	COOLING CAPACITY	PART NO.	COOLING CAPACITY	PART NO.	COOLING CAPACITY
61004A	290 BTU/hr (85 W)	63004A	290 BTU/hr (85 W)	60004A	290 BTU/hr (85 W)
61008A	580 BTU/hr (170 W)	63008A	580 BTU/hr (170 W)	60008A	580 BTU/hr (170 W)
61015A	1100 BTU/hr (322 W)	63015A	1100 BTU/hr (322 W)	60015A	1100 BTU/hr (322 W)
61025A	1800 BTU/hr (527 W)	63025A	1800 BTU/hr (527 W)	60025A	1800 BTU/hr (527 W)
61030A	2100 BTU/hr (615 W)	63030A	2100 BTU/hr (615 W)	60030A	2100 BTU/hr (615 W)
61040A	2900 BTU/hr (849 W)	63040A	2900 BTU/hr (849 W)	60040A	2900 BTU/hr (849 W)

**NEMA Type 3R (IP 14) Continuous Operation C/W Filter and Hose distribution kit**

**NEMA Type 3R (IP 14) On-off Operation C/W Filter, Hose distribution kit, Solenoid Valve & Thermostat**

**NEMA Type 3R (IP 14) Panel Cooler Only**

PART NO.	COOLING CAPACITY	PART NO.	COOLING CAPACITY	PART NO.	COOLING CAPACITY
61004R	290 BTU/hr (85 W)	63004R	290 BTU/hr (85 W)	60004R	290 BTU/hr (85 W)
61008R	580 BTU/hr (170 W)	63008R	580 BTU/hr (170 W)	60008R	580 BTU/hr (170 W)
61015R	1100 BTU/hr (322 W)	63015R	1100 BTU/hr (322 W)	60015R	1100 BTU/hr (322 W)
61025R	1800 BTU/hr (527 W)	63025R	1800 BTU/hr (527 W)	60025R	1800 BTU/hr (527 W)
61030R	2100 BTU/hr (615 W)	63030R	2100 BTU/hr (615 W)	60030R	2100 BTU/hr (615 W)
61040R	2900 BTU/hr (849 W)	63040R	2900 BTU/hr (849 W)	60040R	2900 BTU/hr (849 W)

**NEMA Type 4-4X (IP 66) Continuous Operation C/W Filter and Hose distribution kit**

**NEMA Type 4-4X (IP 66) On-off Operation C/W Filter, hose distribution kit, Solenoid Valve & Thermostat**

**Patented\* NEMA Type 4-4X (IP 66) Panel Cooler Only**

PART NO.	COOLING CAPACITY	PART NO.	COOLING CAPACITY	PART NO.	COOLING CAPACITY
61104X	290 BTU/hr (85 W)	63104X	290 BTU/hr (85 W)	60104X	290 BTU/hr (85 W)
61108X	580 BTU/hr (170 W)	63108X	580 BTU/hr (170 W)	60108X	580 BTU/hr (170 W)
61115X	1100 BTU/hr (322 W)	63115X	1100 BTU/hr (322 W)	60115X	1100 BTU/hr (322 W)
61125X	1800 BTU/hr (527 W)	63125X	1800 BTU/hr (527 W)	60125X	1800 BTU/hr (527 W)
61130X	2100 BTU/hr (615 W)	63130X	2100 BTU/hr (615 W)	60130X	2100 BTU/hr (615 W)
61140X	2900 BTU/hr (849 W)	63140X	2900 BTU/hr (849 W)	60140X	2900 BTU/hr (849 W)



**UPGRADE TO ELECTRONIC CONTROL (ELC)**

Just add ELC to the Thermostatic Control part number and specify voltage (120 V or 240 V)

\*US patent number 8,616,010. Other countries: Patented or Patent Pending.

FRIGID-X™ PANEL COOLER

**NEMA Type 12 (IP 54) Continuous Operation C/W Filter and Hose distribution kit**

**NEMA Type 12 (IP 54) On-off Operation C/W Filter, Hose distribution kit, Solenoid Valve & Thermostat**

**NEMA Type 12 (IP 54) Panel Cooler Only**

PART NO.	COOLING CAPACITY	PART NO.	COOLING CAPACITY	PART NO.	COOLING CAPACITY
61004A-X	290 BTU/hr (85 W)	63004A-X	290 BTU/hr (85 W)	60004A-X	290 BTU/hr (85 W)
61008A-X	580 BTU/hr (170 W)	63008A-X	580 BTU/hr (170 W)	60008A-X	580 BTU/hr (170 W)
61015A-X	1100 BTU/hr (322 W)	63015A-X	1100 BTU/hr (322 W)	60015A-X	1100 BTU/hr (322 W)
61025A-X	1800 BTU/hr (527 W)	63025A-X	1800 BTU/hr (527 W)	60025A-X	1800 BTU/hr (527 W)
61030A-X	2100 BTU/hr (615 W)	63030A-X	2100 BTU/hr (615 W)	60030A-X	2100 BTU/hr (615 W)
61040A-X	2900 BTU/hr (849 W)	63040A-X	2900 BTU/hr (849 W)	60040A-X	2900 BTU/hr (849 W)

**NEMA Type 3R (IP 14) Continuous Operation C/W Filter and Hose distribution kit**

**NEMA Type 3R (IP 14) On-off Operation C/W Filter, Hose distribution kit, Solenoid Valve & Thermostat**

**NEMA Type 3R (IP 14) Panel Cooler Only**

PART NO.	COOLING CAPACITY	PART NO.	COOLING CAPACITY	PART NO.	COOLING CAPACITY
61004R-X	290 BTU/hr (85 W)	63004R-X	290 BTU/hr (85 W)	60004R-X	290 BTU/hr (85 W)
61008R-X	580 BTU/hr (170 W)	63008R-X	580 BTU/hr (170 W)	60008R-X	580 BTU/hr (170 W)
61015R-X	1100 BTU/hr (322 W)	63015R-X	1100 BTU/hr (322 W)	60015R-X	1100 BTU/hr (322 W)
61025R-X	1800 BTU/hr (527 W)	63025R-X	1800 BTU/hr (527 W)	60025R-X	1800 BTU/hr (527 W)
61030R-X	2100 BTU/hr (615 W)	63030R-X	2100 BTU/hr (615 W)	60030R-X	2100 BTU/hr (615 W)
61040R-X	2900 BTU/hr (849 W)	63040R-X	2900 BTU/hr (849 W)	60040R-X	2900 BTU/hr (849 W)

**NEMA Type 4-4X (IP 66) Continuous Operation C/W Filter and Hose distribution kit**

**NEMA Type 4-4X (IP 66) On-off Operation C/W Filter, hose distribution kit, Solenoid Valve & Thermostat**

**Patented\* NEMA Type 4-4X (IP 66) Panel Cooler Only**

PART NO.	COOLING CAPACITY	PART NO.	COOLING CAPACITY	PART NO.	COOLING CAPACITY
61104X-X	290 BTU/hr (85 W)	63104X-X	290 BTU/hr (85 W)	60104X-X	290 BTU/hr (85 W)
61108X-X	580 BTU/hr (170 W)	63108X-X	580 BTU/hr (170 W)	60108X-X	580 BTU/hr (170 W)
61115X-X	1100 BTU/hr (322 W)	63115X-X	1100 BTU/hr (322 W)	60115X-X	1100 BTU/hr (322 W)
61125X-X	1800 BTU/hr (527 W)	63125X-X	1800 BTU/hr (527 W)	60125X-X	1800 BTU/hr (527 W)
61130X-X	2100 BTU/hr (615 W)	63130X-X	2100 BTU/hr (615 W)	60130X-X	2100 BTU/hr (615 W)
61140X-X	2900 BTU/hr (849 W)	63140X-X	2900 BTU/hr (849 W)	60140X-X	2900 BTU/hr (849 W)



**UPGRADE TO ELECTRONIC CONTROL (ELC)**

Just add ELC to the Thermostatic Control part number and specify voltage (120 V or 240 V)

\*US patent number 8,616,010. Other countries: Patented or Patent Pending.



**FRIGID-X™ Patented\* NEMA 4-4X-316L (IP-66) 316L STAINLESS STEEL PANEL COOLER**

All of the other Nex Flow™ FRIGID-X™ Panel Coolers are 303/304 stainless. The Patented NEMA 4-4X-316L (IP-66) FRIGID-X™ Panel Cooler is 316L stainless steel for all exposed areas, ideal for pharmaceutical grade applications and extreme corrosive environments where 303/304 stainless steel material is not adequate.

An Optional 316 stainless steel solenoid valve and thermostat kit is available for on-off control. Compressed air filtration is a must and is the responsibility of the customer in these special environments.

**Patented\* NEMA TYPE 4-4X-316L (IP-66) PANEL COOLER ONLY**

**Patented\* NEMA TYPE 4-4X-316L (IP-66) PANEL COOLER PLUS HOSE DISTRIBUTION KIT**

MODEL	COOLING CAPACITY	SOUND LEVEL	MODEL	COOLING CAPACITY	SOUND LEVEL
60115X-316L	1100 BTU/hr (322 W)	72 dBA	60115XD-316L	1100 BTU/hr (322 W)	72 dBA
60125X-316L	1800 BTU/hr (527 W)	73 dBA	60125XD-316L	1800 BTU/hr (527 W)	73 dBA
60130X-316L	2100 BTU/hr (615 W)	74 dBA	60130XD-316L	2100 BTU/hr (615 W)	74 dBA
60140X-316L	2900 BTU/hr (849 W)	76 dBA	60140XD-316L	2900 BTU/hr (849 W)	76 dBA

OPTIONAL THERMOSTAT AND 316 STAINLESS SOLENOID VALVE FOR ON OFF CONTROL!

**ACCESSORIES:**

MODEL	DESCRIPTION
69004	Cold Air Distribution Kit for all sizes of 316 Stainless Panel Coolers
90018-316	NEMA 4-4X 316 Stainless Steel Solenoid Valve – 110V
90024-316	NEMA 4-4X 316 Stainless Steel Solenoid Valve – 220V
90017	Thermostat Only
90045-316	NEMA 4-4X 316 Stainless Steel Solenoid, 110V plus thermostat kit
90016-316	NEMA 4-4X 316 Stainless Steel Solenoid, 220V plus thermostat kit



**FRIGID-X™ Patented\* NEMA 4-4X-316L (IP-66) 316L STAINLESS STEEL PANEL COOLER WITH HOSE KIT**

**FRIGID-X™ Patented\* NEMA 4-4X-316L (IP-66) 316L STAINLESS STEEL PANEL COOLER MOUNTED ON ELECTRICAL CONTROL PANEL**



\*US patent number 8,616,010. Other countries: Patented or Patent Pending.

**Convert your FRIGID-X™ PANEL COOLER into a “CONSTANT PURGE” System legally and easily with the FRIGID-X™ PANEL COOLER BY-PASS SYSTEM**

**WHAT ARE THEY - REASONS TO USE**

In very dirty environments, you may want continue to have a small amount of compressed air entering the control panel when the panel cooler is not operating (turned off utilizing a solenoid and thermostat package). This is a **“constant purge” system**. One way to do this is to drill a small hole in the solenoid valve but that would be illegal in many jurisdictions or at least against many corporate policies since that would compromise the tested electrical approval integrity of the solenoid. In addition, larger control panels many need to be “purged” with more air flow and small panels only require a negligible amount.

The **FRIGID-X™ PANEL COOLER BY-PASS SYSTEM** accomplishes both tasks. It is easily installed across the solenoid valve to allow for the bypass of some air flow. A control valve on the bypass sets the level of flow desired for the particular control panel where it is utilized. Simple, easy and reliable

The **FRIGID-X™ PANEL COOLER BY-PASS SYSTEM** is made of 316L stainless steel components to handle difficult environments and can be used on all NEMA 12 (IP 52), NEMA 3R (IP 14) and NEMA 4-4X (IP 66) classed applications. The system is easily adjustable for the amount of purge flow you want or need depending on the size of control panel and reliable.

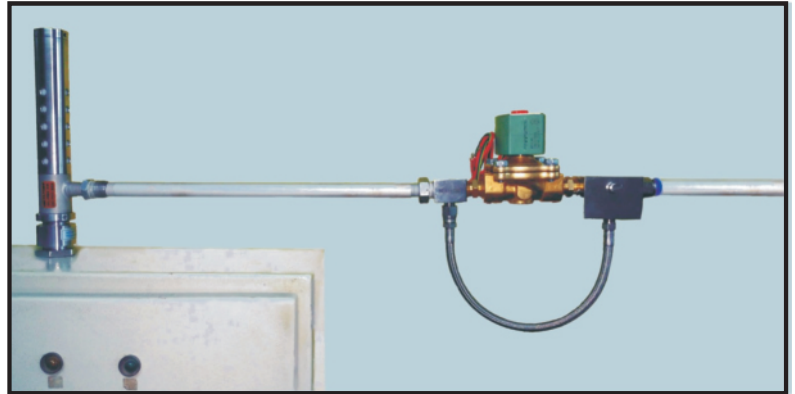

The **FRIGID-X™ PANEL COOLER BY-PASS SYSTEM** allows constant purging with compressed air of a control panel, even when the **FRIGID-X™ PANEL COOLER** is not operating and zero air is flowing through the **PANEL COOLER**.



The **FRIGID-X™ PANEL COOLER BY-PASS SYSTEM** consists of 316L stainless steel parts to withstand difficult factory environments and can be used on all classifications of **Nex Flow™ FRIGID-X™ PANEL COOLERS**.

PART NO	DESCRIPTION
69700	Bypass system consists of 316L Stainless steel tee and 316L Stainless steel combination tee and flow control valve connected together with a stainless bypass stainless hose.



## Nex Flow™ Offers Pneumatic Accessories to help reduce noise levels and improve the environment as well for better operation of product.

**Nex Flow™ and their master distributors and agents worldwide offer and use in the systems:**

- ▶ Filters with Auto Drains
- ▶ Regulators with Gauges
- ▶ Solenoid Valves
- ▶ Shutoff Valves
- ▶ Compressed Air Fittings Hoses
- ▶ and other products to provide one stop shopping

**These products are listed as follows (specifications may vary from one country to the next):**

PART NO.	DESCRIPTION
10991X1 to 10994X2	Mounting System for X-Stream Air Blade Air Knives – See Page M3
10991A1 to 10992A1	Mounting System for Standard Air Blade Air Knives – See Page M3
AMMS to 40002MTS-MS	Mounting System for Air Amplifiers – See Page M3
46002	Two port Manifold for Standard Flow – See Page M7
46002HF	Two port Manifold for High Flow – See Page M7
46004	Four port Manifold for Standard Flow– See Page M7
46004HF	Four port Manifold for High Flow– See Page M7
49400	Temperature Warning Label Sticker for Control Panels – See Page M10
46006	Six port Manifold for Standard Flow– See Page M7
46006HF	Six port Manifold for High Flow– See Page M7
90001	3/8" Filter with Auto drain, 5 micron, 65 SCFM plastic bowl with guard
90002	3/4" Filter with Auto drain, 5 micron, 220 SCFM metal bowl with site glass
90003	1/4" Filter with Manual drain, plastic bowl, 27 SCFM
90004	1/2" Filter with Auto drain, 5 micron, 43 SCFM , plastic bowl
90005	3/8" Oil Removal Filter with Auto drain, 37 SCFM
90006	3/4" Oil Removal Filter with Auto drain, 150 SCFM
90007	NEMA 4X Filter with Auto drain, 5 micron, 1/4" NPT
90008	1/4" Regulator with Gauge, 50 SCFM
90009	3/4" Regulator with Gauge, 220 SCFM
90011	Gauge only, 1/4" NPT 0 - 160 psig
90012	Manual Valve 1/4" NPT
90015	Thermostat & Solenoid Valve Kit (90017+90020) - 120V
90016	NEMA 4-4X Thermostat & Solenoid Valve Kit (90017+90018) - 120V
90017	Thermostat Only
90018	NEMA 4-4X Solenoid Valve Only (120 V)
90019	24 V Solenoid Valve, 1/4" NPT (40 SCFM)
90020	120 V Solenoid Valve, 1/4" NPT (40 SCFM)
90021	240 V Solenoid Valve, 1/4" NPT (40 SCFM)
90023	Gauge only, 1/8" NPT 0 - 160 psig
90101	X-Stream Super Separator NF 200 - 9 SCFM complete with Auto Drain 1/4" See Page M9
90102	X-Stream Super Separator NF 500- 22 SCFM complete with Auto Drain 1/4" See Page M9



PART NO.	DESCRIPTION
90103	X-Stream Super Separator NF 1500 - 64 SCFM complete with Auto Drain 1/2" <b>See Page M9</b>
90024	NEMA 4-4X Solenoid Valve Only (220V)
90027	Oil Removal Filter, 1/4" NPT (Up to 24 SCFM)
90029	Magnetic Swivel Base. <b>See Page M11</b>
90029A	Mini Shut off valve for Magnetic Swivel Base. <b>See Page M11</b>
90034	Medium Size Solenoid Valve, 120V, 1/2" NPT, 100 SCFM
90035	Medium Size Solenoid Valve, 240V, 1/2" NPT, 100 SCFM
90036	Large Size Solenoid Valve, 120V, 1/2" NPT, 200 SCFM
90037	Large Size Solenoid Valve, 240V, 1/2" NPT, 200 SCFM
90038	ELC CONTROL - 110V for Panel Coolers-include Solenoid Valve. <b>See Page M11</b>
90039	ELC CONTROL - 220V for Panel Coolers-include Solenoid Valve. <b>See Page M11</b>
90040	Foot Valve, 1/4" NPT, 60 SCFM
90044	Thermostat & Solenoid Valve Kit (90017+90021) - 240V
90045	NEMA4-4X Thermostat & Solenoid Valve Kit, 240V (90024 + 90017)
90052	1/8" NPT Stainless Steel Swivel Fitting. <b>See Page M11</b>
90053	1/4" NPT Stainless Steel Swivel Fitting. <b>See Page M11</b>
90068	3/8" NPT Stainless Steel Swivel Fitting. <b>See Page M11</b>
90069	1/2" NPT Stainless Steel Swivel Fitting. <b>See Page MN11</b>
90070	1/8" NPTM Reclassifier Muffler. <b>See Page M12</b>
90071	1/4" NPTM Reclassifier Muffler. <b>See Page M12</b>
90072	3/8" NPTM Reclassifier Muffler. <b>See Page M12</b>
90073	1/2" NPTM Reclassifier Muffler. <b>See Page M12</b>
90074	3/4" NPTM Reclassifier Muffler. <b>See Page M12</b>
90075	1" NPTM Reclassifier Muffler
91018	Solenoid for Purge Control Panel Coolers - NEMA 12
91019	Solenoid for Purge Control Panel Coolers - NEMA 4-4X
91020	Spare Capacitor for Thermostat
6RF (MM / MF)	Stainless Steel Rigid Flex Hose which can be flexed to a shape. <b>See Page M13</b>
12RF (MM / MF)	Stainless Steel Rigid Flex Hose which can be flexed to a shape. <b>See Page M13</b>
18RF (MM / MF)	Stainless Steel Rigid Flex Hose which can be flexed to a shape. <b>See Page M13</b>



**NEX FLOW™ MOUNTING SYSTEM FOR AIR BLADE AIR™ KNIVES  
& AMPLIFIERS – Flexible and Durable**

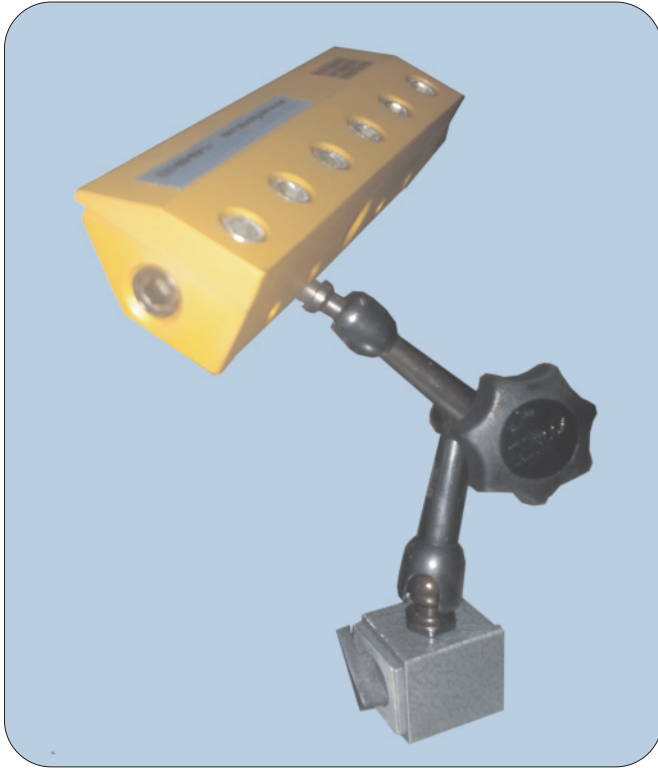

**WHAT THEY ARE – REASONS TO USE**

**Nex Flow™ Mounting Systems** for air knives and amplifiers provide a convenient and flexible way to utilize the products for blow-off and cooling applications. All **Mounting Systems** are made of powder coated steel. One knob controls the infinite flexibility of the system and secures it in place after the air knife or amplifier is properly positioned. Optional magnetic base can secure it to a magnet accepting platform. Rugged and secure positioning.



**MOUNTING SYSTEM FEATURES**

- Flexible and Durable
- Easy to use and install
- Powder Coated Steel
- Optional Magnetic Base

**MOUNTING SYSTEM BENEFITS**

- Infinite flexibility
- Designed for Factory Environments

## NEX FLOW™ MOUNTING SYSTEM FOR AIR BLADE AIR™ KNIVES & AMPLIFIERS – Flexible and Durable

Secure air knives in place quickly and easily with precision mounting.



Air Blade™ Air Knife System comes complete with powder coated brackets and stainless steel mounting screws along with the mounting unit itself. Optional magnetic base, otherwise can secure by threading to a surface.

Air Amplifiers can also be securely and accurately placed using the Nex Flow™ mounting systems.



Standard Model AM10, AM20, and AM40 as well as adjustable Model 40001, and 40002 Air Amplifiers can also be mounted using the mounting arm. As with the Air Blade™ Air Knife System an optional magnetic base can be provided or the unit can be secured by threading to a surface.

## NEX FLOW™ MOUNTING SYSTEM FOR AIR BLADE AIR™ KNIVES & AMPLIFIERS – Flexible and Durable

### MOUNTING SYSTEMS FOR X-STREAM AIR BLADES

PART NO.	DESCRIPTION
10991X1	System for 6" to 18" aluminum and 6" to 15" stainless steel - NF60003 + Bracket + screws
10991X2	TWO systems for aluminum 24" to 54" - 2 sets NF60003 + 2 Brackets + screws
10992X1	System for 18" stainless steel - DG60003 + Bracket + screws
10992X2	TWO Systems needed for 24" to 36" stainless steel - 2 sets DG60003 + 2 Brackets + screws
10993X2	TWO Systems for 42"to 48" stainless steel - 2 sets MG60003 + 2 brackets + screws
10994X2	TWO Systems for 54" stainless steel - 2 sets MG70003 + 2 brackets + screws

### MOUNTING SYSTEMS FOR STANDARD AIR BLADES

10991A1	System for 6" to 18" aluminum and 6" to 15" stainless steel- NF60003 + Bracket + screws
10991A2	TWO systems for aluminum 24" to 54" - 2 sets NF60003 + 2 Brackets + screws
10992A1	System for 18" stainless steel - DG60003 + Bracket + screws
10992A2	TWO Systems needed for 24" to 36" stainless steel - 2 sets DG60003 + 2 Brackets + screws
40001MTS-MS	System for 40001 and 40001G and 40001S- NF60003 + 40001MTS + screw
40002MTS-MS	System for 40002 and 40002G and 40002S - NF60003 + 40001MTS + screw

### MOUNTING SYSTEMS FOR AIR AMPLIFIERS

AMMS	System for AM10, AM20, AM40 - NF60003 + screw
------	---



**OPTIONAL ITEMS**

PART NO.	DESCRIPTION
DG0036-AD6060	Optional mounting magnet for Air Blade Mounting System 10991X1, 10991X2 (Need two for 10991X2) and 10992X1 and 10992X2 (need two for 10992X2) And for Air Amplifier Mounting System
DG0036-AD8080	Optional mounting magnet for Air Blade Mounting Systems 10993X2 and 10994X2 (Need two for 10993X2 and 10994X2)
NF60003	Mounting arm only for 10991X1 and 10991X2 and for AMMS, 40001MTS-MS and 40002MTS-MS
DG60003	Mounting arm only for 10992X1 and 10992X2
MG60003	Mounting arm only for 10993X2
MG70003	Mounting arm only for 10994X2
10999X	Bracket Only for Air Blades plus Screws (5)
10998X	Screws Only (5 screws per kit) for air Blades - EACH
10997X	Bracket Only for X-stream air blade
10999	Bracket for Standard Air Blade (on special order) plus screws (5)
10997	Bracket Only for Standard air blade
MS	Spare Screw for Amplifier Mounting System
40001MTS	Mounting Bracket for Model 40001, 40001G and 40001S
40002MTS	Mounting Bracket for Model 40002, 40002G and 40002S



## Nex Flow™ - MANIFOLD SYSTEM FOR NOZZLES & JETS



**MANIFOLDS FOR MOUNTING OF MULTIPLE NOZZLES, OR AIR JETS & FLAT JETS/AIR EDGERS™.**

Easy to assemble and mount for use with Nex Flow™ blow-off nozzles, jets and Air Edger™ flat jets for blow of various lengths

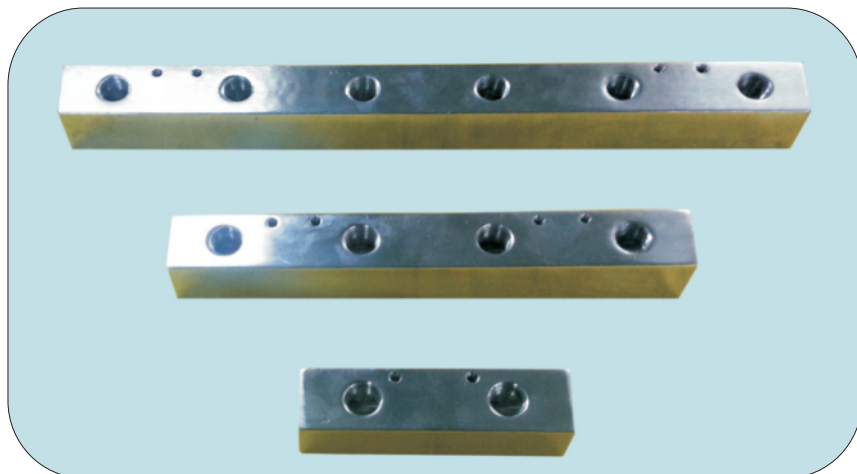

### WHAT THEY ARE – REASONS TO USE

**Nex Flow™ Manifolds** are a convenient way to mount rows of multiple nozzles, air jets and other small blow off products to dry, clean or cool wider surfaces. Come complete with mounting holes. All **Manifolds** are available with air inlet connections at the ends and rear. For smaller air flows, you may use one end connection or rear connection. For larger flows, you need to utilize the two end connections.

Two basic **Manifold** sizes are available with three versions for each: Two (2) outlet unit, Four (4) outlet unit and Six (6) outlet unit. There is the Standard Flow Size and for high flows, the High Flow Size for each version. A flow guide is provided for each version and size.

Manifolds may be held in place with the compressed air piping™ or by using the mounting holes on the units.

### MANIFOLD SYSTEM FEATURES

- Comes in three sizes
- Easy to use and install
- Flexible in use – multiple air inlets

### MANIFOLD SYSTEM BENEFITS

- Allows to easily apply nozzles, jets or other blow off products in rows
- Saves time in installation

## Nex Flow™ - MANIFOLD SYSTEM FOR NOZZLES & JETS



### MANIFOLD SYSTEM - HOW IT WORKS

Nex Flow™ Manifolds come with two (2), four (4) or six (6) – 1/4" outlets. You can use any combination of nozzles, air jets or Air Edgers™ to make a row of blow off product. Easy to mount with compressed air piping or by using the mounting holes supplied.

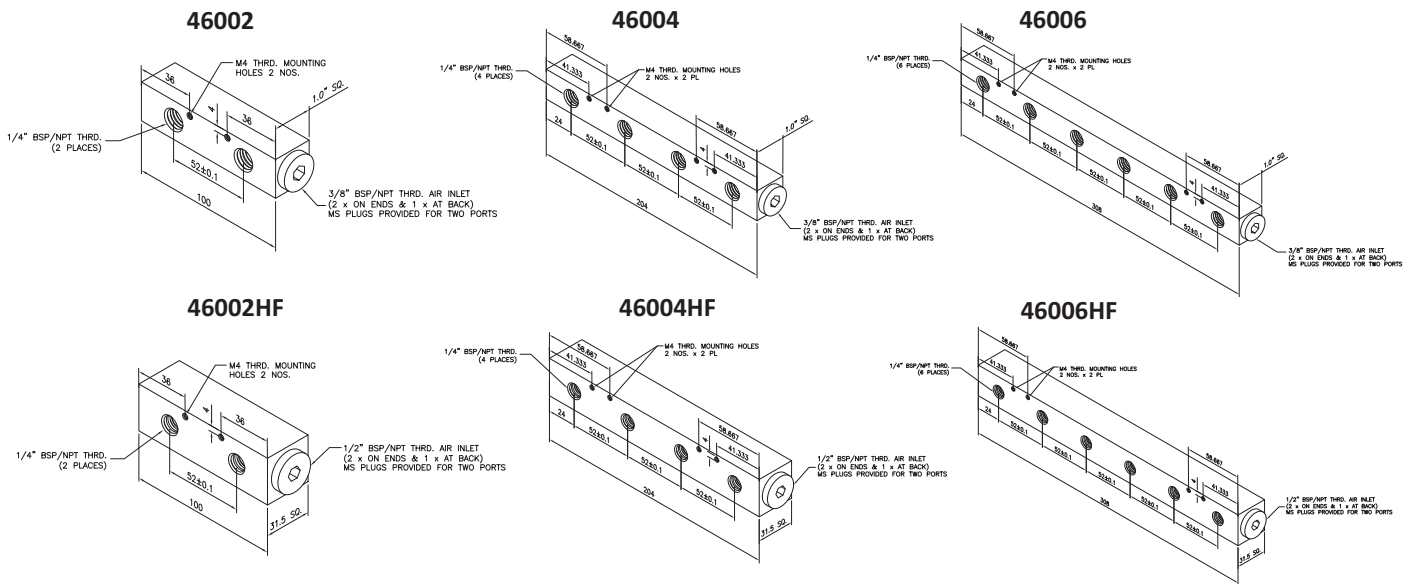

PART NO.	DESCRIPTION
46002	Two outlet Aluminum Anodized Manifold - total flow to 80 SCFM @ 80 PSIG
46004	Four outlet Aluminum Anodized Manifold - total flow to 140 SCFM @ 80 PSIG
46006	Six outlet Aluminum Anodized Manifold - total flow to 220 SCFM @ 80 PSIG
46002HF	Two outlet Aluminum Anodized Manifold - total flow to 120 SCFM @ 80 PSIG
46004HF	Four outlet Aluminum Anodized Manifold - total flow to 210 SCFM @ 80 PSIG
46006HF	Six outlet Aluminum Anodized Manifold - total flow to 320 SCFM @ 80 PSIG

**NOTE:** Using one air inlet allows for 50% of rated flow – using both end air inlets allows for up to 100% of rated flow.



## X-Stream™ Liquid Super Separator

### Element Free Pneumatic Liquid Separator

Newly developed "Liquid Super Separator" is a new concept of a pneumatic mist remover without filter element. The "Element Free Pneumatic Water Separator" uses a special centrifugal technique with "radial multi-nozzles" that is world patent pending and makes it possible to reject liquid mist (water and oil) to 99.9%! This pneumatic mist separator is virtually maintenance free, as there is no need to replace any filter element. A standard traditional filter with an element and automatic drain may be placed downstream to control micron size but the high liquid and mist removal of the separator will keep it clean and it may not require element replacement for an extended period of time. Maintains extremely low pressure drop

#### Features:

- ▶ No filter element
- ▶ Minimal pressure drop
- ▶ Maintenance free
- ▶ Complete mist rejection
- ▶ Mist rejection rate : 99.99%
- ▶ Oil mist rejection rate : 99.99%
- ▶ Semi-permanent durability
- ▶ Power free
- ▶ Complete with Auto-drain
- ▶ No performance change over time
- ▶ Trouble free with simple construction
- ▶ Large capacity but compact
- ▶ Low cost



#### Dimensions: Two standard sizes

NF-200 (9 scfm)      NF-1500 (64 scfm)

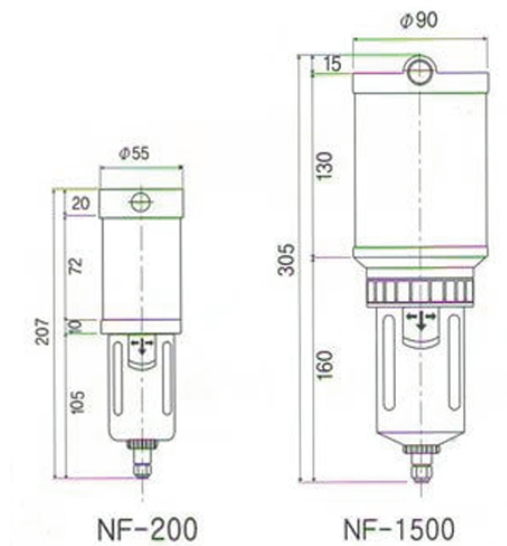



## Specifications

DESCRIPTION	NF-200	NF-1500
Max. operation flow rate SCFM(Nl/min)	9 (200)	64 (1500)
Max. pressure drop (PSIG) (Mpa) {Kgf/cm2}	3.5 (0-0.025) {0-0.25}	
Operating pressure range (PSIG) (Mpa) {Kgf/cm2}	140 (0.01-1.0) {1.0-10.2}	
Max pressure before failure(PSIG) (Mpa) {Kgf/cm2}	172 (1.2) {12.1}	
Fluid temperature range (°F) (°C)	(68 to 140°F) (-20-60°C)	
Type of drain valve	Automatic (can be drained manually)	
Air line connection diameter (inches)	NPT-1/4"	NPT-1/2"
Drain outlet connection diameter (Rc)	1/4 (Ø6.35mm) One touch nipple Type	
Weight (kg)	0.40	1.10
External Dimensions (mm)	Ø55×207	Ø90×305

**SPECIALS**- high pressure units, manual drain types, super large versions and miniature versions can be requested.

### Using The Super Separator

Very large water separators sometimes used upstream to remove liquid but it does not prevent downstream condensation due to the temperature difference between the inside and outside of the compressed air line.

The X-Stream™ Super Liquid Separator is installed at the end of a compressed air main line before a branch line, or just before the outlet of air use for the complete rejection of the mist due to the condensation inside the pipe and also remove any oil mist to 99.9%. This makes it possible to get an essentially maintenance free operation in the control of water and moisture in air line. The only possible part change would be the replacement of the auto drain valve giving the unit a semi permanent life time.

CABINET ENCLOSURE TEMPERATURE WARNING LABEL

For Qualitative Warning of Possible Over Heating of Electrical and Electronic Enclosures, by Nex Flow™ Air Products Corp. [www.nexflowair.com](http://www.nexflowair.com) or [www.nex-flow.com](http://www.nex-flow.com)  
Instructions: Place labels on outside of panel above and to the left with major heat source inside of panel

95°F or 35°C  
WARNING  
HIGH TEMPERATURE

If this label turns **ORANGE**, it is very hot, exceeds the normal range and this heat may cause damage to electrical and electronic components inside. Please check and correct as soon as possible to avoid potential damage.

106°F or 41°C  
DANGER  
EXTREME HIGH TEMPERATURE

If this label turns **RED**, then the heat inside the panel is extreme and can cause serious damage to electrical and electronic components inside. Please check and correct without delay to avoid potential damage.

Temperature indicated is from the outside surface of the panel and temperature inside may actually be slightly more or less. If label indicates warning please check the inside for overheating conditions that may cause damage. If label indicates danger level of possible very hot temperatures please address the problem immediately.  
Please contact Nex Flow™ Air Products Corp. or their local representative to address to Cabinet Enclosure Cooling needs.

Web Site: [www.nexflowair.com](http://www.nexflowair.com) or [www.nex-flow.com](http://www.nex-flow.com)  
USA AND CANADA: 1-877-797-2777 ----- INTERNATIONAL: +1 416 410-1313  
**NOTE:** This Label is designed to indicate surface temperatures only and only to be used as a guide. Proper instrumentation should be used to verify inside temperatures.

With every Panel Cooler you receive a Free Panel Cooler Temperature Warning Indicator Sticker. It will provide a dual qualitative warning level and danger level if the temperature inside your control cabinet is too high. Use on any control panels you wish to monitor. Extra stickers may be purchased from NexFlow - Part Number 69600.



**MAGNETIC BASE**

The Nex Flow™ Magnetic Base is used where the air operated product is required to be frequently moved. The extra strong Magnet allows for flexible Mounting, whether vertical or horizontal. Optional mini shut-off valve can be supplied.

PART NO.	DESCRIPTION
Model 90029	Single Outlet Swivel Magnetic Base - 1/4" NPT
Model 90029A	Mini Shut-off Valve for Magnetic Swivel Base

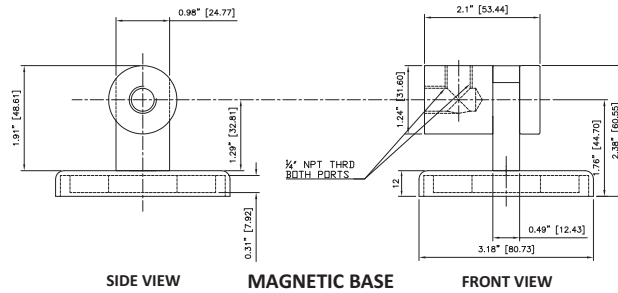

**ELECTRONIC TEMPERATURE CONTROL FOR PANEL COOLERS**

Electronic Thermostat The ELC (Electronic Control Digital Thermostat) is a way for precise control of one or two Nex Flow™ Frigid X™ Panel Coolers.

- ▶ **Supply voltage** : AC 120/240V (24V on request)
- ▶ **Sampling rate** : 4/sec (almost double that of our nearest competitor)
- ▶ **Accuracy** : 0.25% of full scale
- ▶ **3 Outputs** : Two Relay outputs and one with PID, 1SSR output with PID to control external SSR
- ▶ 50 to +100°C measuring range
- ▶ It has Two Alarm settings for the Two output relays so you can set Two different temperatures to control two separate solenoids for two separate coolers (and can be used to control anything electrical)
- ▶ Auto tune mode for quick set ups
- ▶ NEMA 4 Enclosure (ABS/PC), ULC approved- it is accepted anywhere in the world
- ▶ Standard unit comes with one solenoid valve
- ▶ Fahrenheit or Centigrade and easily switchable back and forth

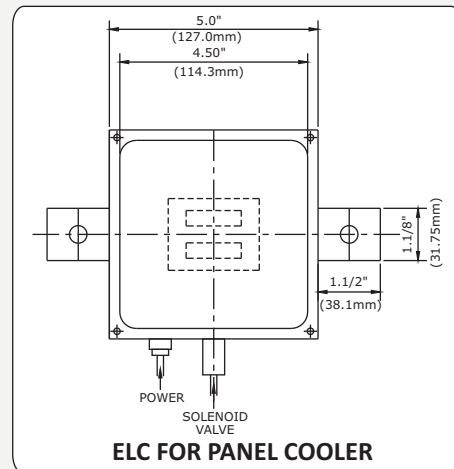

**SWIVEL FITTINGS**

NEX Flow's High Quality STAINLESS STEEL Swivel Fittings for Air Nozzles, Air Jets, small Air Knives, and Air Amplifiers allow for a 25 degree movement from the center axis (50 degree total movement) to aim and then secure in position the blowoff application.

PART NO.	DESCRIPTION
Model 90052	1/8" Stainless Steel Swivel Fitting
Model 90053	1/4" Stainless Steel Swivel Fitting
Model 90068	3/8" Stainless Steel Swivel Fitting
Model 90069	1/2" Stainless Steel Swivel Fitting



**RECLASSIFYING MUFFLERS**

Reclassifying Mufflers provide excellent noise reduction - as much as 35 dBA - and more so than sintered mufflers. In addition they are used to eliminate oil mist.

The exhaust air from valves and cylinders may contain oil mist that can have a negative effect on the health of employees. OSHA standard 29 CFR 1910.10 limits the cumulative exposure to oil mist to 4.32 parts per million (PPM) in any given eight hour work period.

The Reclassifying Muffler we provide uses a patented wrap design for the removable element that separates the oil from the exhausted air virtually trapping all oil in the element. Based on an intake of 50 PPM at 100 PSIG of oil, the exhausted oil mist is reduced to 0.016 PPM. A 1/4" tube can be attached to the bottom reservoir where the oil accumulates to drain it.

Each reclassifying muffler is sized to pass a certain volume of compressed air with minimal restriction to avoid any effect on the operation of cylinder or valve. For cylinders the table below makes the model number easy to choose based on the bore size and stroke of the cylinder.



**RECLASSIFYING MUFFLER**

Muffler needed to Exhaust in 1/2 second for a cylinder charged to 100 PSIG (6.9 BAR)												
STROKE in inches	0.5	1.0	1.5	2.0	2.5	3.0	3.5	4.0	4.5	5.0	5.5	6.0
3	0	0	0	0	0	0	0	0	0	0	0	0
6	0	0	0	0	0	0	0	0	0	1	1	2
9	0	0	0	0	0	0	0	0	1	1	2	2
12	0	0	0	0	0	0	1	1	2	2	2	3
18	0	0	0	0	0	1	2	2	2	3	4/5	4/5
24	0	0	0	0	1	2	2	3	3	4/5	4/5	C
30	0	0	0	0	1	2	2	3	4/5	C	C	C
36	0	0	0	0	2	3	3	4/5	4/5	C	C	C
42	0	0	0	1	2	3	4/5	4/5	C	C	C	C
48	0	0	0	1	2	3	4/5	C	C	C	C	C

- 0 = Model 90070
- 1 = Model 90071
- 2 = Model 90072
- 3 = Model 90073
- 4 = Model 90074
- 5 = Model 90075
- C = Contact Factory or Local Representative for assistance

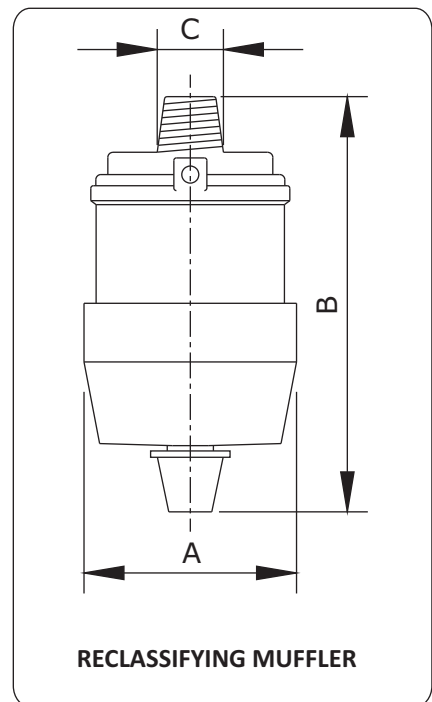

**RECLASSIFYING MUFFLER**

Reclassifying Muffler Dimensions				
MODEL	ØA in Inches (mm)	B in Inches (mm)	C	Replacement Filter Element number
90070	1.63 (41)	3.13 (80)	1/8" NPT	9007071R
90071	1.63 (41)	3.13 (80)	1/4" NPT	9007071R
90072	2.44 (62)	4.75 (121)	3/8" NPT	9007273R
90073	2.44 (62)	4.75 (121)	1/2" NPT	9007273R
90074	3.31 (84)	6.25 (159)	3/4" NPT	9007475R
90075	3.31 (84)	6.25 (159)	1" NPT	9007475R

**RIGID FLEX HOSE**

The unique Nex Flow™ RIGID FLEX Hose is an all stainless steel hose that does not break after a few bends like competitive rubber hoses with simple copper inserts. It is resistant to creep and crimping. Its all stainless construction allows its use in any difficult environment.

The Nex Flow™ RIGID FLEX Hose is used to flex, direct and then hold in place air nozzles, air jets and other small blow off products such as our Model 40001 adjustable air amplifier and 3" X-Stream™ Air Blade™ Air Knife. The RIGID FLEX Hose can also be used with liquid spray jets.

The rigid flex hose is available in three different sizes 6" (152 mm), 12" (304 mm) and 18" (457 mm) and in two configurations - 1/4" male NPT welded end connection both ends or 1/4" male NPT welded connection one end and female NPT welded connection other end.

Rigid-Flex Hose used to mount an aim a Model 47010 air nozzle and connected at the other end to the Magnetic Base creating a portable blow off station.

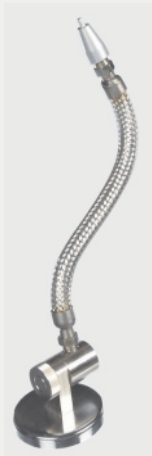

Rigid-Flex Hose comes in Three sizes 6" (152 mm), 12" (304 mm), 18" (457 mm) and two configurations 1/4" Male Male or 1/4" Male Female Threads.



PART NO.	DESCRIPTION
6RF MM	6" overall length 1/4" NPT male to 1/4" NPT male connections
6RF MF	6" overall length 1/4" NPT male to 1/4" NPT female connections
12RF MM	12" overall length 1/4" NPT male to 1/4" NPT male connections
12RF MF	12" overall length 1/4" NPT male to 1/4" NPT female connections
18RF MM	18" overall length 1/4" NPT male to 1/4" NPT male connections
18RF MF	18" overall length 1/4" NPT male to 1/4" NPT female connections

## AIR AMPLIFICATION EXPLAINED AND HOW IS IT MEASURED

### THE HONEST APPROACH TO COMPRESSED AIR BLOW OFF AND COOLING

The industry providing air amplification technology consists of few producers of any consequence and many small firms producing often poor quality or cheap knock-offs with little in-house technical support or knowledge. The technology may seem relatively simple as a concept but it is not always easy to maintain a high quality product.

What is even more important is the technical support that is provided and accurate verifiable data that a designer and user can apply confidently. Nex Flow™ Air Products Corp. attempts to provide the necessary education, support and “verifiable” data the customer needs. Always be wary of data provided when it seems unreasonable (and unverifiable), and especially when you see the data just copied from one source to the next with no explanation of what it means when they may not even have produced any in house tests.

### WHAT IS AIR AMPLIFICATION ?

Air amplifiers, also called air movers, are energy “converters”. They convert the higher pressure of compressed air (usually between 60 to 120 PSIG or 4 to 6 bar) to a high flow rate at lower pressure utilizing the “Coanda effect”. The Coanda effect is the tendency of a jet of fluid (in this case air) to stay attached to an adjacent curved surface that is very well shaped. The principle was named after aerodynamics pioneer Henri Coanda. It does not create energy from nothing. It “converts” energy and would probably be better called an energy converter. Some results of this effect are much less energy loss from pressure drop, lower noise levels in air flow, and a high velocity “laminar” flow. This allows for a more efficient and strong blowoff force and cooling effect than if the compressed air exited a simple hole or nozzle not using the coanda effect. The larger the amplifier physically, the more efficient it becomes as a flow amplifier. This is why nozzles are not as efficient as larger Air Jets and annular amplifiers.

### HOW IS AIR AMPLIFICATION MEASURED ?

Before you can assess “how much” air amplification is (also called the “amplification ratio”), you need to know how it can be measured. In addition to air amplification due to the coanda effect, there is “additional” air amplification downstream of the entrained air caused by the “coanda” angles. For our Standard Air Amplifiers, actual tests were done utilizing a complex testing rig consisting of orifice plates and manometer tubes and a tubular fixture with an anemometer that measured output velocity. The velocity was measured at the exit and downstream after air entrainment. The velocity figure as measured at the exit “before” downstream entrainment is significantly higher as the entrainment will slow down the velocity dramatically. The amplified air from the “coanda effect” is amplified many times in increasing volume as you move further downstream away from the amplifier outlet. At even a small 6” distance away, the amplification ratio can go up approximately by a factor of 3. These measurements must be made under standard conditions because, if the entrained air is warmer, it will actually move faster and the amplification ratio and velocities could be greater. So realistically, the “air amplification” ratio is always a gross estimate in real life applications. Similar logic should be used on published velocity figures. You may measure a velocity figure of 5000 feet per minute and see a published figure several times that number but it may only be an approximation or estimation “before” considering downstream entrainment. Nex Flow™ provides only verifiable data that can be used. The measured and verifiable figure is the most useful and realistic. Be very wary of extremely high velocity claims that you may not even be able to approximate in real life applications.



## WHAT AMPLIFICATION MEANS ?

Note that the figures used in our data for amplification ratio for Air Amplifiers is the nearest realistic estimate between 60 psig (4.2 bar) and 120 psig (8.4 bar). Amplification ratio will depend on volume, pressure, atmospheric conditions and geometric design of the product itself. It can actually be a bit “higher” at lower pressures but we utilize the figures between 60 psig (4.2 bar) and 120 psig (8.4 bar) as this is the usability range for most applications. Annular Air Amplifiers peak out at about an air amplification ratio of 16 at an inlet pressure of 100 psig (7.0 bar) to 120 psig (8.4 bar). This is at the outlet before downstream entrainment. At lower pressures 20psig (1.4 bar) to 30 psig (2.1 bar) amplification ratios can reach as much as 20. Be wary of extremely high air amplification ratio claims. Downstream entrainment can be estimated at 3 times the amplified air at the outlet at a distance of 6” to 12” depending on the size of the amplifier. Downstream amplification will depend on “actual” velocity at that point as well as the dimensions of the amplifier itself. So when you see figures that do not seem logical, by all means ask for an explanation. For Air Blade™ Air Knives, the efficiency for amplification will be less than it would be for a mid-size “annular” Air Amplifier. The general estimate for air amplification is 9 to 10 times in the industry for the standard version, before downstream entrainment. It is about 13 times for the X-stream™ design versions because of the secondary surface for entrainment (30% boost is estimated). This again is based on the geometry of the Air Knives themselves and by interpolation using measurable force figures and air consumption figures. It is difficult to get an accurate measurement of velocity of an air knife without this downstream entrainment because of its geometry as compared to the annular shaped air amplifiers. For Air Knives with two exit slots, again, be wary of high amplification ratio claims.

At 6” from the exit of an Air Knife, convention estimates that the amplification ratio will go up by a factor of 3 which represents an amplification ratio of approximately 30 for a Standard Air Blade™ Air knife and 40 for an X-stream™ version. Again, these are estimates and can vary with both compressed air and atmospheric air conditions. Some firms have used an amplification ratio of 25 times which is just as reasonable an estimate. For products essentially the same dimensionally, great variations should not occur. At a distance greater than 6”, the amplification ratio will go up but not linearly because the velocity slows down with further air entrainment. So at 12” the air amplification does not suddenly double and in fact will go up maybe another 30% and decrease further after that. Remember these are estimates. Estimates provided by Nex Flow™ are realistic estimates.

## DUCTING AMPLIFIERS

Air Knives are not normally ducted. However air amplifiers can be ducted to convey fumes, gases & light materials. Because Air Amplifiers are highly subject to back pressure, the “amplification ratio” will go down dramatically if an Air Amplifier is ducted. Nex Flow™ technical support can advise on the actual amplified flows for any specific application you may have for “ducted” Air Amplifiers if this is required for any specified projects.

## HOW TO COMPARE PRODUCTS

Nex Flow™ strives to maintain verifiability in technical data provided and not “stretch” data to an unrealistic degree. Data provided is obtained by direct measurement and / or reasonable interpolations. All charts and graphs provided are “best fit” information made from actual data & interpolations usable for engineering purposes. This information is usable and accurate within reasonable variation from any normal errors from any measurement. If you suspect a competitive claim as unrealistic, we can provide a realistic explanation and even provide a comparable product on loan to do a “comparative” performance test. The easiest comparison is to set the two similar products at the same pressure, and measure the force utilizing a sensitive scale. Realistically, if they are similar in design they will perform almost the same. Claims of small changes in things like shims rarely have any major effect on amplification ratios and performance when compared on exactly the same basis. If velocity is important velocity meters are also readily available for a relatively qualitative measurement. Be wary of extremely high velocity claims.

**WHAT YOU WANT**

The most important thing is that the product does the job it was purchased for and that it provides the performance and savings you want. For this, both accuracy and the knowledge of the provider are of utmost importance. It is clear that Nex Flow™ Air Products Corp. has the experience to provide the technical support required for this unique and important technology. For this reason, so few returns of our products occur. We do not just send something to “try” wasting valuable time. We want both us and the customer to have utmost confidence in our products.

**AMPLIFICATION PRODUCTS**

The products that can be classified as Air Amplifiers are as per the following sections:

**Section B :-** Air Blade™ Air Knives- linear amplification to replace rows of nozzles, slots and drilled pipe.

**Section C :-** Ring Blade™ Air Wipes- split amplifiers for use in extrusion processes.

**Section D :-** Air Amplifiers- the traditional annular amplification products which are the most efficient for many blow off and cooling applications as well as for venting and conveying of light materials.

**Section E :-** Air Nozzles and Jets- smaller amplifiers, and although not as efficient as larger amplifiers, they do save on air, improve safety and reduce noise levels, and because of the laminar flow produced, have a greater effective distance for blow off.

**Section F :-** Air Guns utilize mainly the air nozzles and jets for effective energy and noise reduction as well as for safety.



## VORTEX TUBE EXPLAINED AND PERFORMANCE MEASUREMENT

### THE HONEST APPROACH TO VORTEX TUBE PERFORMANCE

The industry providing Vortex Tube cooling technology, as with air amplification consists of few producers of any consequence and many small firms producing often poor quality or cheap knock-offs with little in-house technical support or knowledge. The technology involved in making a Vortex Tube is more complex than amplification and tight tolerances must be maintained for a consistent, and quality product.

Technical support is critical in the use of Vortex Tubes and Vortex Tube products to avoid misapplication and to get maximum benefit from this unique technology. Nex Flow™ Air Products Corp. attempts to provide the necessary education, support and “verifiable” data the customer needs. Always be wary of data provided when it seems unreasonable (and unverifiable), and especially when you see the data just copied from one source to the next with no explanation of what it means when they may not even have produced any in house tests.

### WHAT IS A VORTEX TUBE ?

The Vortex Tube is also known as the Ranque - Hilsch Vortex Tube and is a mechanical device that separates compressed air (or any inert gas) into hot and cold streams. The Vortex Tube was invented in 1933 by French physicist Georges J. Ranque. Physicist Rudolf Hilsch improved the design and published a widely read paper in 1947 on the device, which he called a Wirbelrohr (the literal translation means whirl pipe).

A Vortex Tube has no moving parts. Compressed air is injected tangentially into a “generator” which causes the air to rotate at a high speed. It rotates to the opposite end of the Vortex “Tube”. By using a conical “plug” at this opposite end, the outer shell of the compressed air escapes. The remainder of the air is forced to return in an inner vortex of reduced diameter within the outer vortex back through the center hole of the “generator”.

There are different explanations for the effect and there is debate on which explanation is best or correct. What is usually agreed upon is that the air in the tube experiences mostly "solid body rotation", which simply means the rotation rate of the inner gas is the same as that of the outer gas. In other words - they have the same angular velocity. This is different from what most consider standard vortex behavior where inner gas spins at a higher rate than outer fluid. The (mostly) solid body rotation is probably due to the long time in which each parcel of air remains in the vortex allowing friction between the inner parcels and outer parcels to have an effect.

One simple explanation is that the outer air is under higher pressure than the inner air (because of centrifugal force). Therefore the temperature of the outer air is higher than that of the inner air.

Another explanation is that as both inner and outer vortices rotate at the same angular velocity and direction, the inner vortex loses angular momentum. The decrease of angular momentum is transferred to the outer vortex in the form of kinetic energy, resulting in separated flows of hot and cold air. This is analogous to the Peltier effect which uses electrical pressure (in this case voltage) to move heat to one side of a dissimilar metal junction, causing the other side to grow cold.

### ACTUAL VORTEX TUBE PERFORMANCE

There have been many advertisements by Vortex Tube manufacturers who claim ever lower temperature outputs from year to year with virtually no technical change. It is appropriate to explain what you can actually get in performance. The most commonly used chart for Vortex Tube performance is shown on the next page.



**Approximate temperature drops (and rises) from inlet air temperature produced by a Vortex Tube set at various cold fractions. Assume constant inlet pressure and temperature.**

Pressure Supply	Cold Fraction %						
	20	30	40	50	60	70	80
20 (1.4)	62 (34)	60 (33)	56 (31)	51 (28)	44 (24)	36 (20)	28 (16)
	15 (8)	25 (14)	36 (20)	50 (28)	64 (26)	83 (46)	107 (59)
40 (2.8)	88 (48)	85 (46)	80 (42)	73 (39)	63 (34)	52 (28)	38 (20)
	21 (11)	35 (18)	52 (28)	71 (38)	92 (50)	117 (62)	147 (80)
60 (4.1)	104 (57)	100 (55)	93 (51)	84 (46)	73 (40)	60 (33)	46 (25)
	24 (14)	40 (22)	59 (33)	80 (44)	104 (57)	132 (73)	166 (92)
80 (5.5)	115 (63)	110 (62)	102 (56)	92 (51)	80 (45)	66 (36)	50 (28)
	25 (14)	43 (24)	63 (35)	92 (51)	113 (63)	143 (80)	180 (100)
100 (6.9)	123 (68)	118 (65)	110 (61)	86 (47)	86 (48)	71 (39)	54 (30)
	26 (14)	45 (25)	67 (37)	100 (55)	119 (66)	151 (84)	191 (106)
120 (8.4)	129 (72)	124 (69)	116 (64)	90 (50)	91 (50)	74 (41)	55 (31)
	26 (14)	46 (26)	69 (38)	104 (58)	123 (68)	156 (86)	195 (108)

**The cold fraction is the “percentage flow” of the air coming out at the cold end. So a 60 percent cold fraction means 60% of the air comes out the cold end and 40% would go out the hot end.**

The table above is actually quite accurate (but still “approximate”) for the medium sized vortex tubes operating with 10 to 15 SCFM flow design. The performance can deviate significantly for the higher flow designs. However, it is generally not important to get such “low” temperatures and in most applications the Vortex Tubes are “preset” to provide a specific temperature drop. But if very low temperatures are required, it is recommended to use the lower capacity (10 to 15) SCFM designs. The reasons for the deviation from the chart in the larger capacities are primarily one of physical design, but are generally not important in most applications. The table is applicable ONLY to Nex Flow™ Vortex Tubes with “H” generators. Vortex Tubes with “C” generators produce very cold temperatures as the generator design is different and high cold outlet flows are restricted, allowing for very cold temperatures to be produced but with low cold end flow. The “C” generators are for producing cold temperatures and not for high BTU/hr. (or watt) cooling effect. The sections following will focus on vortex tubes with the “H” generators only.

The cold end output temperature depends on the temperature of the incoming compressed air temperature. For example, if the compressed air source is 10° F (-12.2°C), at a pressure of 100 PSIG (6.9 bar), then almost any supplier of Vortex Tubes can claim to be able to achieve a temperature of -100° F (-73.7°C) with a cold fraction setting of 40%. “Cooling effect” is governed by both temperature drop created in the Vortex Tube AND the actual flow exiting the cold end. Colder temperatures produced do NOT always mean the highest cooling effect is produced. In a Vortex Tube, cold end air flow and temperature drop vary inversely with each other as the “cold fraction” changes. The cooling effect is a balance and combination of both temperature drop and outlet flow.

Referring to the cold fraction chart, the “cold” temperature drop listed is actually the cold temperature drop “inside” the Vortex Tube. Once the cold air leaves the Vortex Tube it is subject to mixing with the (normally warmer) ambient air. If the cold air is piped from the Vortex Tube through a hose or pipe, the temperature will also rise due to conduction. If you measure (or estimate from the chart) an “inside temperature of 32° F (0°C), you may actually only get 40° F (4.4°C), at the point of use.



Most Vortex Tube designs, even if they look significantly different from the outside, are actually quite similar inside. Nex Flow™ prides itself on quality workmanship and proprietary production standards to be consistent in performance and have high performance compared to competitive products. Even if we manage to get an extra one (1) degree drop at a given cold fraction, it translates into energy savings over the long term. This is achieved using metal generators that are consistent in dimension and not molded plastic which can change as the mold wears. Other proprietary machining techniques employed by Nex Flow™ create a consistent, high quality & superior performing product.

### THE BEST TEMPERATURE SETTING FOR VORTEX TUBES

There is a misconception that the colder the temperature the better the Vortex Tube in a cooling application. Except where the cold temperature is of importance (such as in cooling an environmental chamber) it is best to have the temperature drop set to between a 60 percent to 80 percent cold fraction. If the output temperature is too low, you can actually get “ice” forming because of the condensation from the air inside the Vortex Tube falling below the dew point of the compressed air. This causes the Vortex Tube to stop working.

Too cold a temperature can be a problem if the dew point is reached. In addition, since temperature drop and flow out the cold end are interdependent and vary inversely with each other, should the temperature drop be too great, you get less flow and can actually achieve “less” cooling effect. The optimum setting for cooling is therefore between a 60% and 80% cold fraction. If the temperature of the incoming compressed air is hot, it is better to use a 60% cold fraction. If the incoming temperature of the compressed air is around standard conditions or cool, it is better to use a cold fraction of 80%. Normal setting for a cold fraction to address the vast majority of applications is approximately a 70%.

### HOW TO COMPARE PRODUCTS

Nex Flow™ strives to maintain verifiability in technical data provided and not “stretch” data to an unrealistic degree. Data provided are “best fit” information made from actual data and usable for engineering purposes. This information is usable and accurate within reasonable variation from any normal errors from any measurement. If you suspect a competitive claim as unrealistic, we can provide a realistic explanation and even provide a comparable product on loan to do a “comparative” performance test. Materials of manufacture are also important in assessing value. Nex Flow™ Air Products Corp. manufactures all Vortex Tubes and Vortex Tube packages (panel coolers, tool coolers, spot coolers, etc.) in stainless steel. The important internal generators and other parts are metal (brass, stainless or other metals). All the seals and O-rings are made from quality viton. Special materials such as silicone are also available on request.

### WHAT YOU WANT

The most important thing is that the product does the job it was purchased for and that it provides the expected performance and savings. For this, both accuracy and the knowledge of the provider are of utmost importance. It is clear that Nex Flow™ Air Products Corp. has the experience to provide the technical support required for this unique and important technology. For this reason, so few returns are made. We do not just send something to “try” wasting valuable time. We want both us and the customer to have utmost confidence in our products and technical support. All of our agents worldwide are trained to provide consistent and honest guidance.

### VORTEX TUBE PRODUCTS

The products that can be classified as vortex tube products are as per the following sections:

**Section J** :- Vortex Tubes and Adjustable Spot Coolers Small and Medium Sized Vortex Tubes also provided in packages as an Adjustable Spot Cooler and as a Mini Cooler.

**Section K** :- Tool Coolers for cooling cutting tools, grinding wheels and for other dry machining and even non-machining applications where spot cooling can improve the product or output speed.

**Section L** :- Panel Coolers for control panels. Maintenance free and reliable - even in difficult environments. Versions for NEMA Type 12 (IP-52), NEMA Type 3R (IP-14) and NEMA Type 4-4x (IP-56) applications.



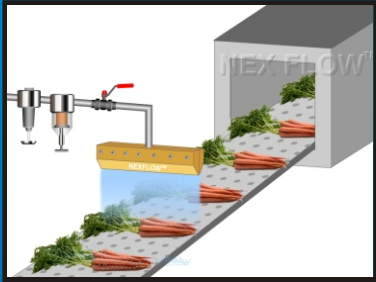

**Vegetable Blowoff**

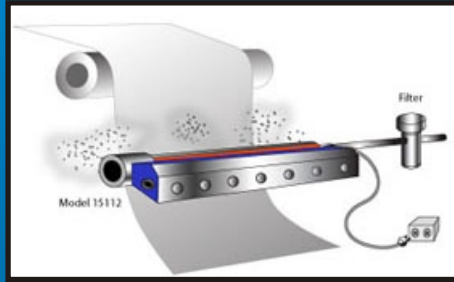

**Air Blade Ionizer in packaging**

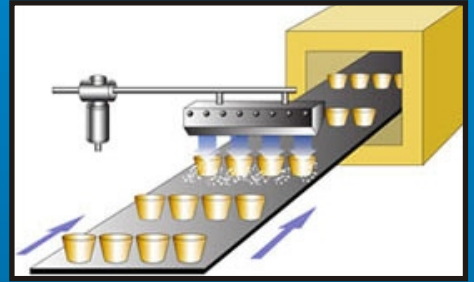

**Muffin Sugar Blowoff**

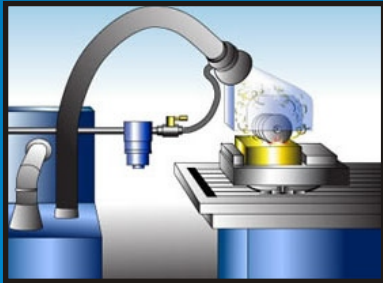

**Adjustable Air Amplifier  
Removes  
Dust In Grinding Application**

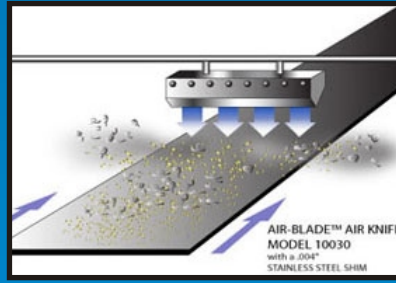

**Cleaning Conveyor**

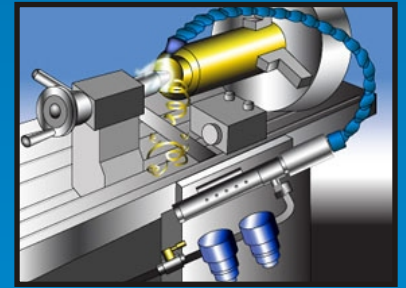

**Tool Cooler on lathe**

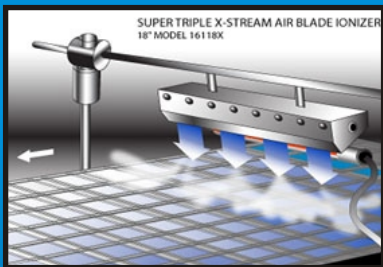

**Air Blade Ionizer for  
Thermoforming**

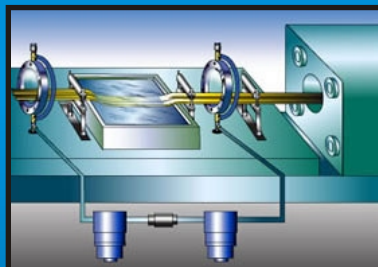

**Blow-Off For Extruded  
Automotive Trim**



**Cooling Injection Molded  
Plumbing Parts**

# NEX FLOW™

AIR PRODUCTS CORP.



- |              |             |              |        |             |          |             |          |           |
|--------------|-------------|--------------|--------|-------------|----------|-------------|----------|-----------|
| Argentina    | Australia   | Bahrain      | Brazil | Canada      | Chile    | China       | Colombia | Cyprus    |
| Denmark      | Ecuador     | Estonia      | France | Germany     | Greece   | Hungary     | India    | Indonesia |
| Iran         | Ireland     | Israel       | Italy  | Japan       | Kenya    | Korea       | Kuwait   | Malaysia  |
| Mexico       | Netherlands | Nigeria      | Norway | Philippines | Portugal | Qatar       | Romania  | Russia    |
| Saudi Arabia | Singapore   | South Africa | Spain  | Sri Lanka   | Sweden   | Switzerland | Taiwan   | Thailand  |
| Turkey       | UAE         | USA          | UK     | Ukraine     | Vietnam  | Zambia      |          |           |

Nex Flow™ Air Products Corp.  
300 International Drive, Unit 100  
Williamsville, NY, 14221

For USA and Canada :

Tel : Toll Free: 877-797-2777  
Fax : Toll Free: 877-797-2660

Nex Flow™ Air Products Corp.  
10520 Yonge Street, Unit 35B-220  
Richmond Hill, ON, Canada, L4C 3C7

International Contact :

Tel: +1-416-410-1313  
Fax: +1-416-410-180 or +1-716-626-3001

